

Technical Datasheet



Thermowells

Bar stock or manufactured type

Key Features

- Solid bar stock construction or machined from a pipe
- 1 piece, forged construction available
- Different materials available or covered with PTFE
- Full penetration welds available
- Flanges according to ANSI, DIN standard
- ASME PTC 19.3 Stress calculation available
- Stop Ring available in case of need
- Special and customised construction



Series Overview

Thermowells are a very important component for all temperature measurements. They are used to protect the sensing element of the temperature instrument from corrosion abrasion and high pressures.

It allows the measuring instrument to be removed for recalibration or replacement, without interrupting the flow or stopping the process.

The bar stock thermowells are available in parallel, tapered or step manufactured variations as required.

We offer a large number of variants, such as customised thermowell designs or materials, to meet the specific requirements of our customers. The high accuracy and quality of production is an important aspect for our thermowells.

Other products

Other products we can offer :

- Flanged/threaded chemical seals
- Manifolds
- Overrange protectors, snubbers, electric contact





Product applications

- Chemical, petrochemical industry
- Power and steam generation
- Food and pharmaceutical industry
- Marine and offshore application
- Oil & Gas
- Water Treatment
- Fire fighting system
- Hydraulic systems

How can we help you?

Delta Mobrey offers fast, efficient and knowledgeable support when and where you need it. Please visit our website at www.delta-mobrey.com to find your local support centre or call us on: **+44 (0)1252 729140**

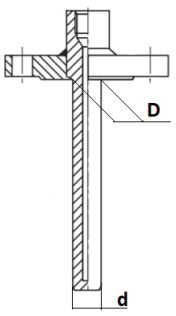
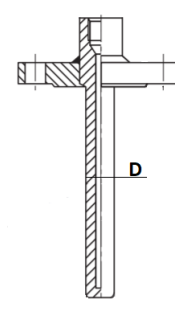
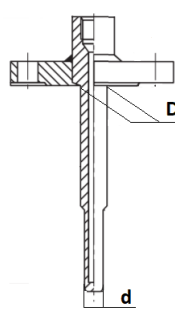
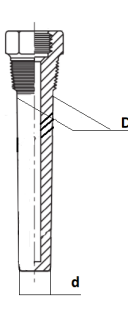
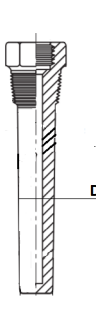
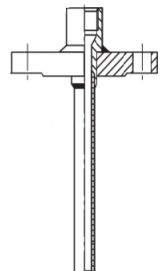
Type and Construction

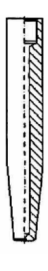
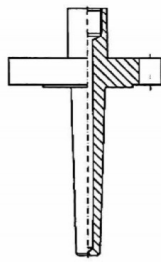
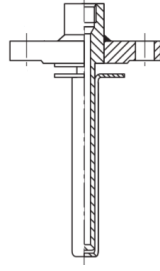
STANDARD BARSTOCK TYPE FLANGED OR THREADED				
FT	FP	FR	ST	SP
FLANGED, TAPERED	FLANGED, PARALLEL	FLANGED, REDUCED TIP	SCREWED, TAPERED	SCREWED, PARALLEL
				
SPECIAL CONSTRUCTIONS ON REQUEST				
CODE 37----(For special construction)				
FLANGED, FROM PIPE	SCREWED, FROM PIPE	BARSTOCK, WELDED DIN TYPE	ONE PIECE, FORGED	COVERED WITH PTFE, EXOTIC MAT.
				

Thermowells Bar stock or Manufactured type	GENERAL CHARACTERISTICS	Bar stock type Material	AISI316L, AISI316TI, AISI304, DUPLEX, SAF2205, Hastelloy, Monel 400, Inconel 625, F51, F22, and others on request
		Pipe Material	AISI316L, AISI304, P22, others on request
		Flange type	Blind as standard, Slip-on on request
		Welding	Single, full penetration as option
		Flange material	AISI316, AISI316TI, AISI304, and others on request
		Flanged connection	ANSI: 1/2, 3/4, 1, 1 1/2, 2, 3, 4, and others on request DIN 15, 20, 25, 40, 50, 80, 100, and others on request
		Flange Rating	ASME: 150, 300, 600, 900, 1500, 2500 DIN: 16, 25, 40, 100
		Flange finish	RF, RTJ
		Threads	NPT, BSPP, BSPT
		Bore diameter	Suitable for stem 4,6,9,10,12,14 outer diameter
		Insertion length	As requested
		Standard length over "U"	50mm (no extension)
		Standard thickness at end	6mm
		Standard surface roughness	0.8 μ (▽▽▽)
Flange marking	Flange size/rating/material/tag		
ASME PTC 19.3 calculation	Stress calculation, as requested		
EN10204 3.1	Material Certificate		
Pressure test	Available on request		
Liquid penetrant Test	Available on request		
Customized drawing	Available on request		

STANDARD FLANGED THERMOWELLS

Tapered stem

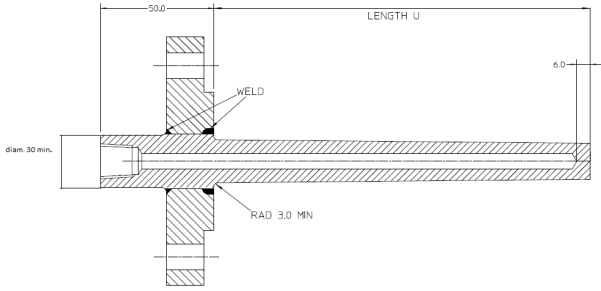

Parallel stem

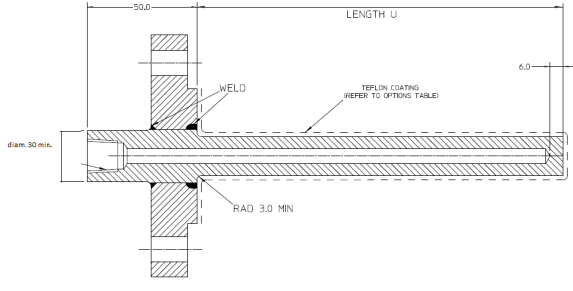

Reduced tip

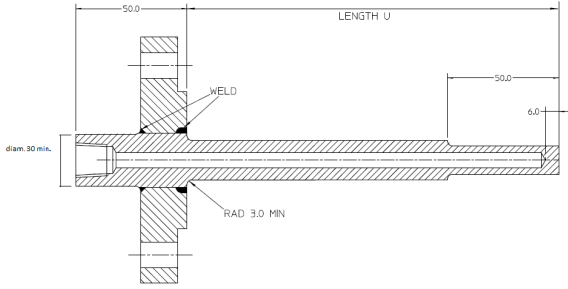

Models

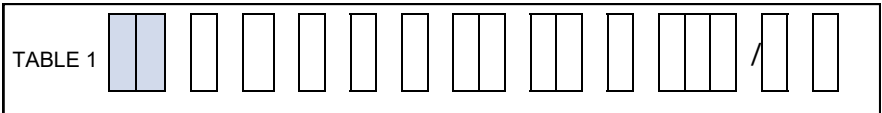

Description	Code
Bar stock flanged, Parallel Stem	FP
Bar stock flanged, Parallel Stem and Reduced Tip	FR
Bar stock flanged, Tapered Stem	FT

Materials

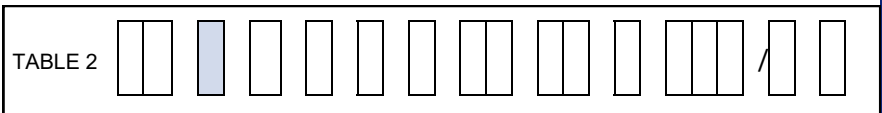

Description	Code
AISI 304	A
AISI316L	B
AISI310	C
Inconel 600	D
Monel 400	E
Hastelloy C	F
Carbon Steel	H
Inconel 625	K
Stainless Steel Duplex	L
Stainless Steel Duplex S31803(2205)	N

Thermowells
Bar stock or Manufactured type

**Process Connection
(Flange Size)**

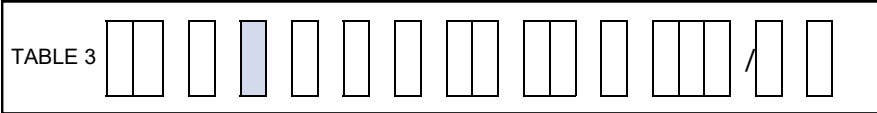

Description	Code
1/2" to ANSI B 16.5	D
3/4" to ANSI B 16.5 or DN20 to BS4504	E
1" to ANSI B 16.5 or DN25 to BS4504	F
1 1/2" to ANSI B 16.5 or DN40 to BS4504	H
2" to ANSI B 16.5 or DN50 to BS4504	J
3" to ANSI B 16.5 or DN80 to BS4504	K

Flange Rating

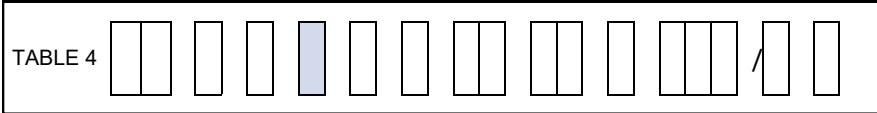

Description	Code
150 lbs.	A
300 lbs.	B
600 lbs.	C
900 lbs.	D
1500 lbs.	E
2500 lbs.	F
PN6	G
PN10	H
PN16	I
PN25	J
PN40	K

Flange Face

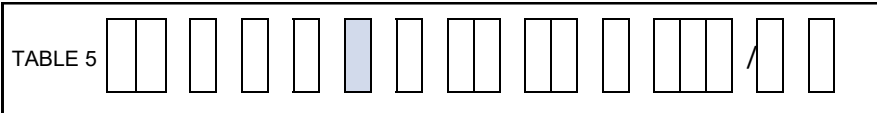

Description	Code
Raised Face RF	R
Flat Face FF	F
Ring Joint RTJ	J

Instrument Connection

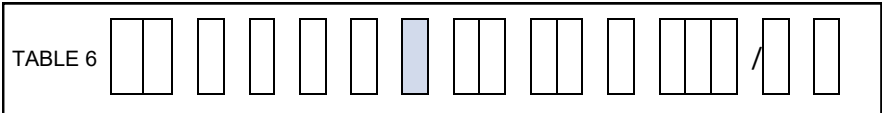

Description	Code
3/8 " NPT	A
1/2 "NPT	B
R1/2 " BSPT	C
G1/2 " BSPP	E

Stem Diameter at Connection

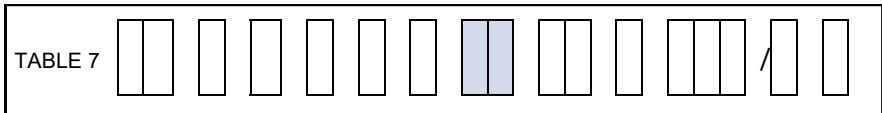

Description	Code
44 mm	44
43 mm	43
39 mm	39
37 mm	37
35 mm	35
34 mm	34
33 mm	33
32 mm	32
30 mm	30
28 mm	28
27 mm	27
26 mm	26
25 mm	25
24 mm	24
22 mm	22
19 mm	19
18.5 mm	18
17 mm	17
16 mm	16
12 mm	12

Thermowells
Bar stock or Manufactured type

Stem Diameter at Tip

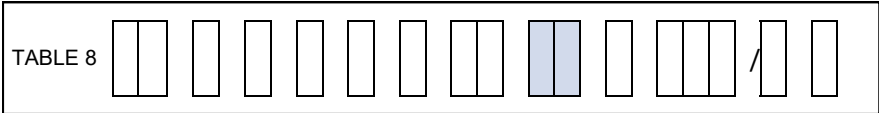

Description	Code
18 mm	AH
44 mm	44
43 mm	43
39 mm	39
37 mm	37
35 mm	35
34 mm	34
33 mm	33
32 mm	32
30 mm	30
28 mm	28
27 mm	27
26 mm	26
25 mm	25
24 mm	24
22 mm	22
19 mm	19
18.5 mm	18
17 mm	17
16 mm	16
12 mm	12

Bore Diameter

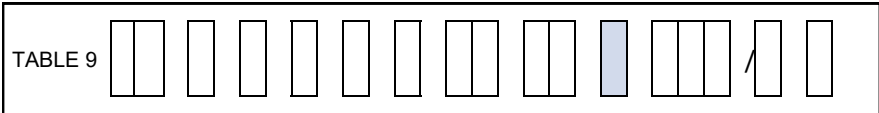

Description	Code
6.2 – 6.4 mm (for stem 6mm OD)	A
9.8 – 10 mm (for stem 9.5mm OD)	B
12.5 – 12.8 mm (for stem 12mm OD)	C
17 – 17.5 mm (for stem 16mm OD)	D
8.3 – 8.5 mm (for stem 8mm OD)	E

'U' Length

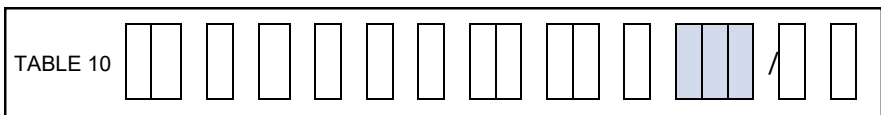

Description	Code
U Length in mm	XXXX

Options

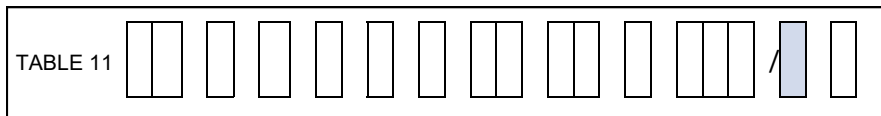

Description	Code
None required	0
Tag no. stamped on flange	1
Full penetration welds	2
Supplied with screw plug and chain	3
Teflon Jacket (17µm thick Min.) wetted parts incl. Flange face	4
Tag no. stamped on flange and full penetration welds	A
Tag no. stamped on flange and screw plug and chain	B
Tag no. stamped on flange and full penetration welds and screw plug and chain	C
Tag No. stamped on Flange and Teflon Jacket (17m Min.) On Wetted Parts	D

Treatments

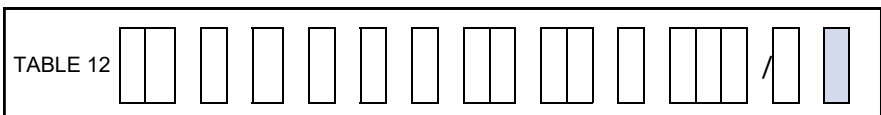

Description	Code
None required	0
Nace MR 01-75 compliant material	1
Dye penetrant weld inspection	2
Radiograph inspection (X-Ray)	3
NACE MR 01-75 and MR 01-03 compliant material	5
NACE MR 01.75 and MR 01.03 compliant material + Dye penetrant weld inspection	A
Dye penetrant weld inspection + Radiograph inspection (X-Ray)	B
NACE + Dye penetrant weld inspection + Radiograph inspection (X-Ray)	C

Thermowells
Bar stock or Manufactured type

STANDARD THREADED THERMOWELLS

Tapered and parallel Stem

Total length for **TAPERED** thread process connection = U+50
 Total length for **PARALLEL** thread process connection = U+25

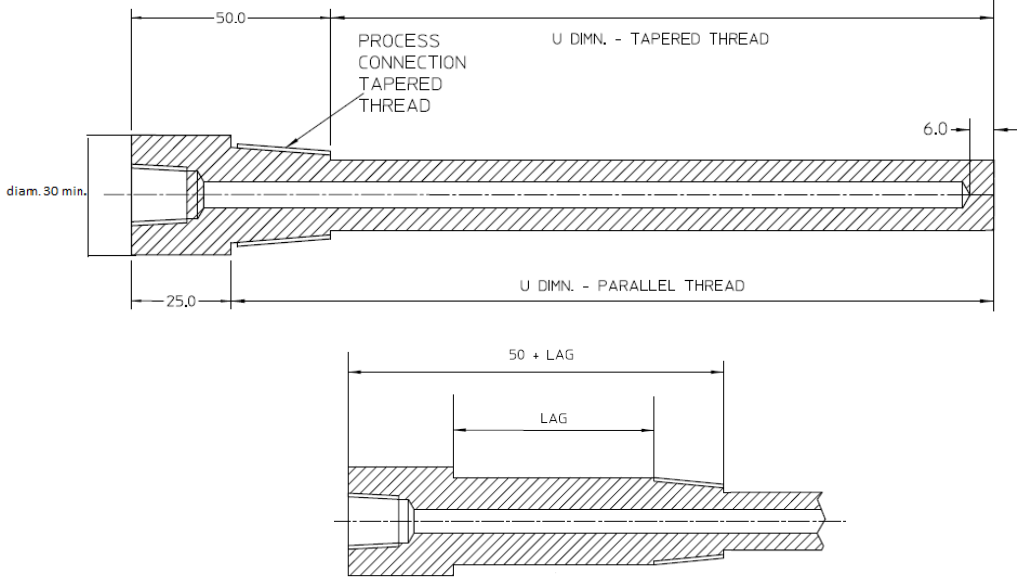

Models

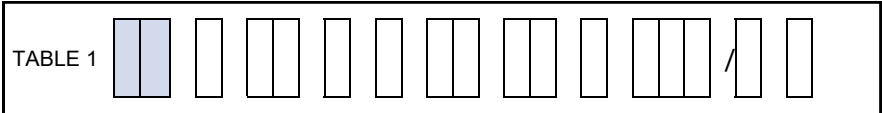

Description	Code
Bar stock threaded, Parallel	SP
Bar stock threaded, Tapered	ST

Materials

Thermowells
Bar stock or Manufactured type

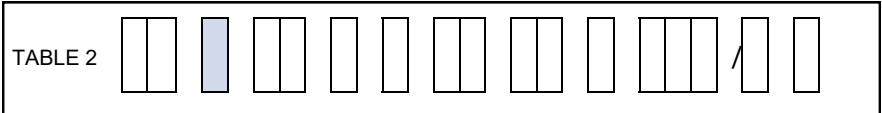

Description	Code
AISI 304	A
AISI316L	B
AISI310	C
Inconel 600	D
Monel 400	E
Hastelloy C	F
Carbon Steel	H
Titanium Gr2	M
Inconel 625	K
Stainless Steel Duplex	L
Stainless Steel Duplex S31803(2205)	N

**Process Connection
(Thread Size)**

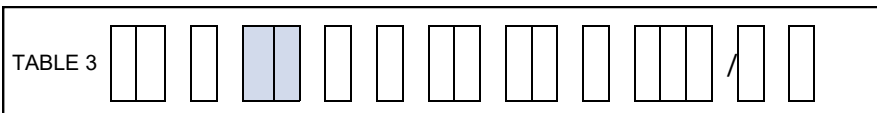

Description	Code
1/2" NPT external	DN
G1/2" (1/2" BSPP external)	DP
R1/2" (1/2" BSPT external)	DT
3/4" NPT external	EN
G3/4" (3/4" BSPP external)	EP
R3/4" (3/4" BSPT external)	ET
1" NPT external	FN
G1" (1" BSPP external)	FP
R1" (1" BSPT external)	FT
G 1 1/4" (1 1/4" BSPP external)	GP
M20x1.5 external	HM

Instrument Connection

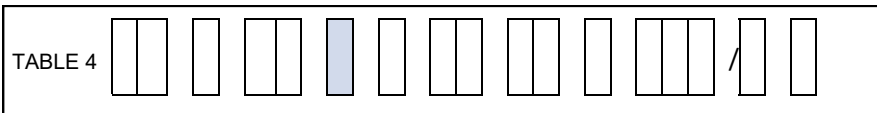

Description	Code
3/8" NPT Internal	A
1/2" NPT internal	B
Rc1/2" (1/2" BSPT internal)	C
R3/8" (3/8" BSPT Internal)	D
G1/2" (1/2" BSPP internal)	E
M20x1.5 internal	F

Lagging Extension

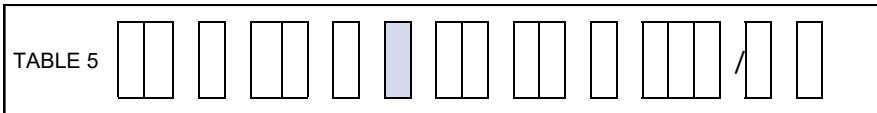

Description	Code
None required	0
25 mm Long	A
50 mm Long	B
75 mm Long	C
100 mm Long	D

Thermowells
Bar stock or Manufactured type

Stem Diameter at Connection

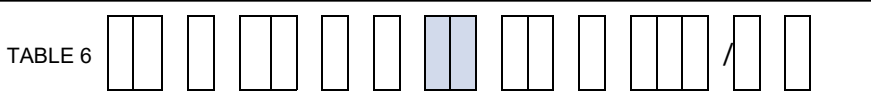

Description	Code
12 mm	12
16 mm	16
17mm	17
19 mm	19
26 mm	26
27 mm	27

Stem Diameter at Tip

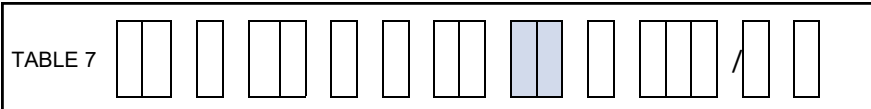

Description	Code
12 mm	12
16 mm	16
17mm	17
19 mm	19
26 mm	26
27 mm	27

Bore Diameter

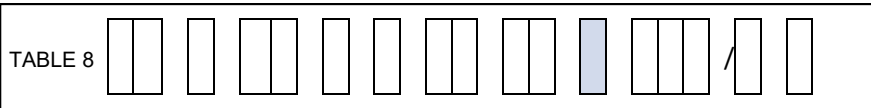

Description	Code
6.2 – 6.4 mm (for stem 6mm OD)	A
9.8 – 10 mm (for stem 9.5mm OD)	B
12.5 – 12.8 mm (for stem 12mm OD)	C
17 – 17.5 mm (for stem 16mm OD)	D
8.3 – 8.5 mm (for sensing element 8mm OD)	E

'U' Length

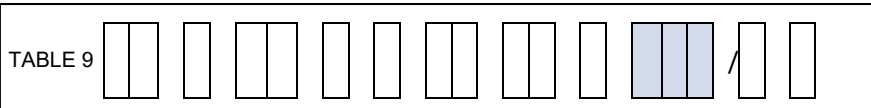

Description	Code
U Length in mm	XXXX

Thermowells
Bar stock or Manufactured type

**Correct Dimensioning of
Insertion Length of
Thermowells**

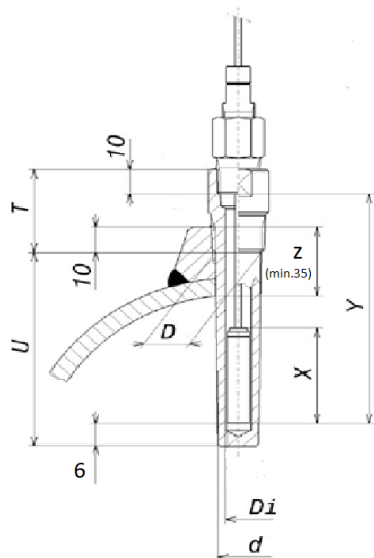

For our flanged and threaded thermowells type :
FT, FR, FP, SP, ST
length "T" is 50mm as standard.

In case of thermowell with extension, this must be considered and added.

<p>Where:</p> <p>Sensor dimensions: D= outer diameter of bulb X= length of sensitive part (=bulb) Y= stem length Z= dimension of the process connection</p> <p>With all thread tapered type, 10 mm of insertion must be considered. With parallel type threads, 25mm of insertion must be considered.</p>	<p>Thermowell dimensions: Di= inside diameter (bore) de= external diameter U= insertion length (length below thread/flange) T= remaining length (insertion + thread/flange + nut) EXCLUDING extension</p>
--	--

Relationship between dimensions T;U;X;Y
 $U \geq X+Z$ (insertion length must be higher than bulb length + dimension of connection)
Y (with all **tapered threads**) = $U+T-16\text{mm}$ (= total length of the thermowell, less 10mm for insertion of the thread and 6mm for thickness of the bottom of the thermowell)
Y (with all **parallel threads**) = $U+T-31\text{mm}$ (= total length of the thermowell, less 25mm for insertion of the thread and 6mm for thickness of the bottom of the thermowell)
X must be always fully immersed in the fluid, so X must be $< U-Z$

<p>CASE 1</p> <p>Given: "X" & "Z", select "U" min and "Y" (considering a tapered thread and no extension) $U \text{ min} = X+Z+10\text{mm}$</p> <p>Example: WTO2 having: Bulb "X" = 81 ; Coupling length "Z" = 50mm</p> <p>$U \text{ min} = 81+10 = 91\text{mm}$ $U+T = 91+50 = 141\text{mm}$ $Y \text{ min} = 141 - 16\text{mm} = 125\text{mm}$</p>	<p>CASE 2</p> <p>Given: "X" and "U", select "Y" (considering a tapered threads and no extension) Check first of all that following rules are respected : $X < U-Z$ and $U \text{ min} = X+Z+10\text{mm}$</p> <p>Then: $Y \text{ min} = U+(T-16\text{mm})$ extension, if any</p> <p>Example: WTO2 having $X=81\text{mm}$ Immersion "U" = 150 ; $Y = 150 + 31 = 181\text{mm}$</p>
--	---

Thermowells
Bar stock or Manufactured type