

Technical Datasheet



2HT Series SMART Pressure Transmitter Model: 2HT

Key Features

- High Accuracy $\pm 0.10\%$
- Ranges from 1 bar to 1000 bar
- 20 : 1 turndown
- 4-20mA analogue with digital communications
- Fully HART ® compatible
- Rugged 316 stainless steel investment cast enclosure
- NEMA 4X, IP66 Environmental Rating
- Stainless Steel, and Hastelloy “Wetted Parts” options
- NACE MR-01-75 compatibility
- Compact, Robust design
- All welded construction

Series Overview

The model 2HT has a compact, robust, all stainless steel construction making it particularly suited to the harsh corrosive environments of offshore applications .

For applications where the ambient temperature can vary significantly, the 2HT can be supplied with an optional high accuracy calibration enabling the accuracy to be maintained within 0.1% for ambient temperatures ranging from -30°C to $+70^{\circ}\text{C}$.

Other related products:

- D23 SMART Pressure Transmitter



Product applications

The 2HT is suitable for a wide range of applications in many industry sectors:

- Oil & Gas
- Chemical
- Petrochemical
- Water
- Power

The choice of models available ensures that the 2HT suitable for use in:

- Corrosive atmospheres
- Resistant to chemical attack

How can we help you?

Delta Mobrey offers fast, efficient and knowledgeable support when and where you need it. Please visit our website at www.delta-mobrey.com to find your local support centre or call us on:

+44 (0) 1252 729140

Smart Pressure Transmitter
Model: 2HT

How to order

Transmitters can be configured by selecting codes representing the desired features from the tables that follow. The chart below, describes how the model code is built up. For assistance in configuring a switch that best suits your needs, please contact your local sales office.

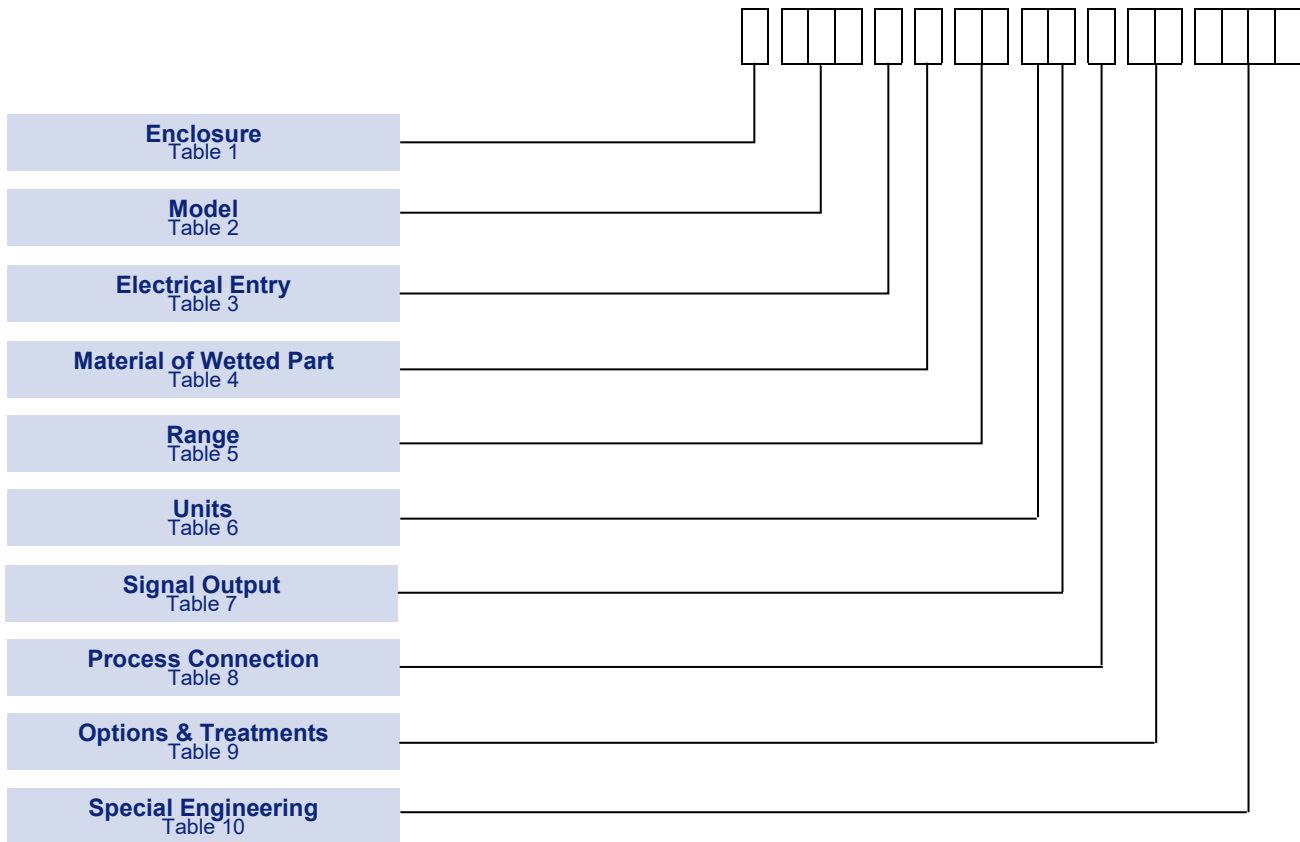

NOTE: Options shaded in the following tables are the most common options and are available on the quickest lead-times and at the lowest cost.

NOTE: Only the most common options are shown in this data sheet. Should you require a feature that is not shown, please contact your local sales office for further details.

Technical Specification

Smart Pressure Transmitter Model: 2HT	Accuracy:	For turndowns of 1:1 to 10:1 ± 0.1% of span. For turndowns of 10:1 to 20:1 ± 0.15% of span. Accuracy stated includes the combined effects of Linearity, Hysteresis, and Repeatability.
	Temperature limits:	Process: -40 to +120°C (-40 to +240°F) Operating: -40 to +85°C (-40 to +185°F) Storage: -50 to +110°C (-58 to +230°F).
	Ambient Temperature effects:	Total effect ±0.1% at maximum span.
	Humidity limits:	0 to 100% relative humidity
	Enclosure classification:	IP66 / NEMA 4X / Flameproof Ex d / Intrinsically safe Ex ia
	Signal output:	See Table 7.
	Electrical rating:	See Table 6.
	Process Connection:	See Table 8.
	Weight:	Without local display 1.6kg; With optional local display 1.8kg; Wall mount bracket 0.2kg; Pipe mounting bracket 0.5kg; Remote D-CAL unit 0.2kg.

Enclosure



FINISH

All enclosures are investment cast in 316 Stainless Steel and offer environmental protection to (NEMA TYPE 4X) IP66.

NOTE

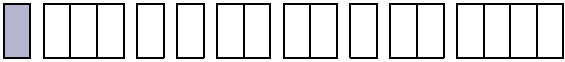
Instruments subject to National or International approval may be limited in terms of options available. See notes adjacent to relevant tables.

TABLE 1 

ENCLOSURE TYPES	Code
Intrinsically Safe Enclosure (Zone 0)	
Intrinsically Safe to EN60079-0 & EN60079-11 & EN 60079-26 Ga Ex ia IIC T4 @ -20 to +80° 	4
Flameproof Enclosure	
Flameproof to EN50 014 & EN50 018 EEx d IIC T4 @ -40 to +85°C (for Blind Instruments) EEx d IIC T6 @ -40 to +60°C (for Blind Instruments) EEx d IIB + H2 T6 @ -40 to +60°C (for Indicating Instruments) EEx d IIB + H2 T6 @ -40 to +85°C (for Indicating Instruments) Refer also to note on table 7 	R
Weatherproof	
Weatherproof only IP66 / NEMA 4	A

Model

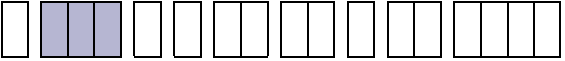
TABLE 2 

	Code
Pressure transmitter.	2HT

Electrical Entry

M20 x 1.5 (ISO) and 1/2" NPT Internal threads available as standard. Other threads e.g. Pg 13.5, can be made available via adaptors.

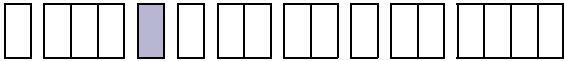
TABLE 3 

	Code
M20 x 1.5 Internal thread (standard)	1
1/2" NPT Internal thread	2

Material of Wetted Parts

Options U and C are all compatible with the requirements of NACE MR 01-75. Other factors in highly aggressive chemical environments may determine the final choice.

For Sour-gas and Crude applications, Code C offers the most cost-effective solution.

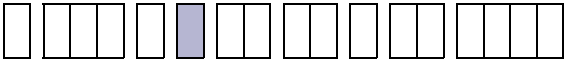
TABLE 4 

	Code
For liquids and gases. Welded 316 stainless steel sensor and process connection. Ranges 0 to 1 bar up to 0 to 6 bar.	R
For liquids and gases. Welded 17-4 PH or 15-5 PH sensor to 316 stainless steel process connection. Ranges 0 to 10 bar up to 0 to 1000 bar.	S
Welded Hastelloy C sensor and process connection. Ranges 0 to 10 bar up to 0 to 1000 bar. (Suitable for NACE MR-01-75).	U
Welded Hastelloy C sensor to annealed stainless steel process connection. Ranges 0 to 10 bar up to 0 to 1000 bar. (Suitable for NACE MR-01-75)	C

Smart Pressure Transmitter
Model: 2HT

Setting Ranges

The values shown in this table are the UPPER RANGE LIMIT (URL); a 20:1 turndown facility enables full 4 to 20mA output to be obtained for a working span equal to 5% of URL.

Unless specified, the instruments are despatched with

LOWER RANGE VALUE (LRV) set to LOWER RANGE LIMIT and

UPPER RANGE VALUE (URV) set to UPPER RANGE LIMIT.

Ranges shown are to gauge (i.e. atmospheric reference) absolute pressure is called up by amending the last character of the three character range code:

NOTE: Model R 2HT is not available on ranges below 10bar.

TABLE 5

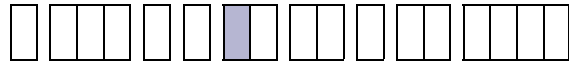

Bar	PSI	Code
0 to 1	0 to 16	DA
0 to 2	0 to 30	D2
0 to 6	0 to 100	DE
0 to 10	0 to 160	EA
0 to 16	0 to 250	EB
0 to 40	0 to 600	ED
0 to 100	0 to 1600	FA
0 to 400	0 to 6000	FD
0 to 600	0 to 10,000	FE
0 to 1000*	0 to 16,000	GA

*NOTE: Range GA only available with SS or Hastelloy Process connection

Units

TABLE 6

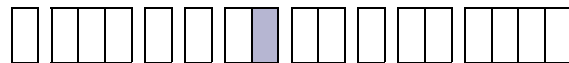

UNITS	Code
Gauge	G
Absolute	A

Signal Output

TABLE 7

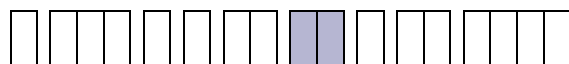

NOTE:

For Flameproof model R2HT, gas group reduced to IIB+H2 when option codes 2 & B are selected. Also refer to table 1

All 4-20mA with digital signal based on the HART® protocol.

Codes A and B are only available with wetted part material codes C or U. Ref Table 4.

	Code
50 V DC Maximum voltage between circuit and case, blind instrument.	1
50 V DC Maximum voltage between circuit and case, instrument with indicator.	2
500 V AC Maximum voltage between circuit and case, blind instrument.	A
500 V AC Maximum voltage between circuit and case, instrument with indicator.	B

Process Connection

Other thread specifications and sizes are available without using adaptors.

Adaptors are available for applications where their use is permitted.

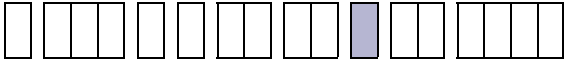
TABLE 8 

	Code
1/2" NPT Male external (standard)	J
G1/2"A to ISO 228 (1/2" BSP Parallel Male, spigotted)	N
High Pressure Cone and Thread (Autoclave) 9/16" UNF	V

NOTE: All 1/2" NPT process connections are limited to a maximum pressure of 1200 bar/17500 psi.

Options and Treatments

For requirements that fall outside the specifications listed above we will be pleased to advise on your particular application.

TABLE 9 

	Code
Tagging – Wired on Stainless steel tag	30
Applies when no option is required and selection is made from SPECIAL ENGINEERING	00

Special Engineering

Last 4 digits of model code only used when special engineering is required.

TABLE 10 

	Code
Please consult Delta sales engineering for special requirements.	TBA

Accessories

Order as separate items.

	Code
Hand held indicator/configurator (DCAL)	IDCL
Modem (For PC Serial Port)	9400012
Panel mounting clamp in stainless steel	9HTBW
2" Pipe mounting clamp in stainless steel	9HTBP

Technical Specifications

Process

Liquid, gas or vapour applications.

Ranges

0 to 1bar up to 0 to 1000bar. (0 to 16psi up to 0 to 16,000psi.)

Outputs

Two-wire, 4-20mA DC output with Digital AC signal superimposed onto it, using the HART® protocol.

Power Supply

9 to 55 Volts DC. On intrinsically safe circuits the maximum voltage is limited to 28VDC.

Load Limits

The maximum loop resistance is determined by the voltage level of the power supply.

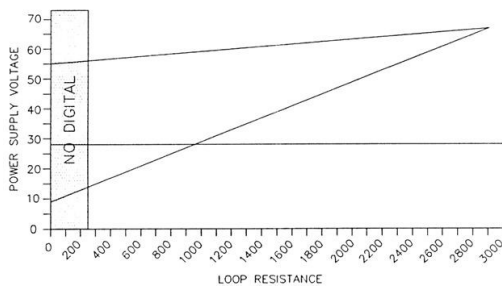

Digital communication requires a minimum loop resistance of 230 ohms.

Indication

Optional Local Display.

Hazardous Area Certification

ATEX Intrinsically safe and flameproof.

Zero Elevation & Suppression

Can be set anywhere within the sensor limits, providing the required span is greater or equal to the minimum span, the lower range value does not exceed the lower range limit, and the upper range value does not exceed the upper range limit.

Normal or Reverse Action

Set by reversing the upper and lower range values.

Overpressure

316 St. St. diaphragm 2 x URL

17-4 PH or 15-5 PH diaphragm 2 x URL*

Hastelloy diaphragm 1.5 x URL*

*Subject to 1500 bar maximum.

Temperature Limits

Process: -40 to +120°C (-40 to +240°F)

Operating: -40 to +85°C (-40 to +185°F)

Storage: -50 to +110°C (-58 to +230°F)

Failure Mode Alarms

"Burnout" indication can be selected to be either minimum or maximum current output.

Humidity Limits

0 to 100% relative humidity.

Turn-on Time

Performs within specifications in less than 3 seconds, after power is applied to the transmitter including full self-diagnosis.

Volumetric Displacement

Less than 0.01cm³

Damping

Adjustable 0 to 39 seconds. This is in addition to the sensor response time of 150mS.

Performance specifications

Accuracy

For turndowns of 1:1 to 10:1 ±0.1% of Span

For turndowns of 10:1 to 20:1 ±0.15% of Span

Accuracy stated includes the combined effects of Linearity, Hysteresis, and Repeatability.

Stability

Typically less than ±0.1% URL per annum.

Linearity

±0.05% of calibrated span.

Ambient Temperature Effects

Total effect ±0.1% at maximum span.

Overrange Effect

Zero shift, 0.2% URL.

Step Response

Less than 150mS.

Vibration Effect

5g Peak sinusoidal at 5Hz to 200Hz.

Power Supply Effect

0.005% of calibrated span per volt.

Mounting Position Effect

Zero shift of up to 2mbar for a 10° tilt in any place.

RFI Effect

With lid on, in accordance with IEC801, level 3 (30V/m) over the range 20Mhz to 1000Mhz.

Physical Specifications

Electrical Entry

M20 x 1.5 Internal or 1/2" NPT Internal.

Process Connections

1/2" NPT External (Standard).

Autoclave, 'Cone and Thread' 9/16" UNF (For pressure ranges up to 1000bar.)

External G 1/2" A to ISO 228.

Process Wetted Parts

316 St. St.

17-4 PH St. St. or 15-5 PH.

Hastelloy.

Non-Wetted Parts

Lower body, Case and Lid 316 Stainless Steel.

Mounting Hardware 316 Stainless Steel.

Environmental Protection

IEC IP66, NEMA 4X.

Mounting

Direct process mounting as standard.

Optional 2" pipe mounting bracket.

Optional wall mounting bracket.

Programming, configuration & display functions

The model 2HT SMART transmitter uses the HART® protocol, enabling digital communications with host computer systems, universal hand-held communicator and any other process control system that supports the HART® protocol; as a result it can be configured and calibrated remotely.

In addition to remote digital communications, the Model 2HT has a standard local Zero and Span adjustments at the touch of a button.

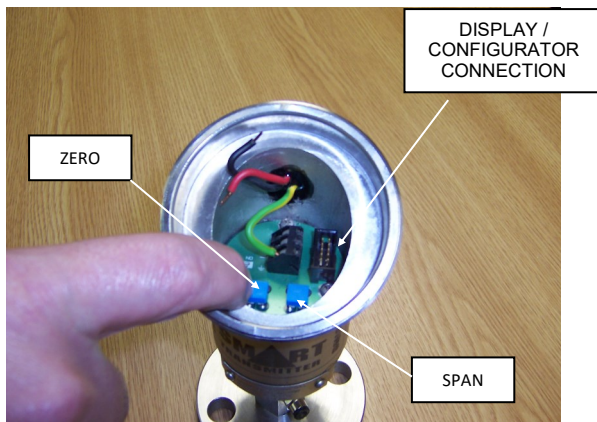

If more than just local Zero and Span is required, there is the unique D-CAL local display option.

The Delta D-CAL local display is more than just a local indicator, it is, in fact, a local configurator, that can directly access more than 80% of the SMART transmitter commands, for installation, commissioning and maintenance checks.



The D-CAL local display unit is constructed from a single, stainless steel disc and when fitted gives the transmitter an environmental rating of IP65 with the lid removed.

The display gives diagnostic capabilities and shows prime variable and temperature, it also contains a user friendly, alphanumeric menu allowing access to internal functions including password protection. Passwords can be enabled to limit operation access to critical parameters during operation.

If a local display is not required, but the ability to check and configure the model 2HT is still needed, then our unique hand held configuration is a low cost alternative, when purchasing two or more transmitters.



Once the first unit is configured, simply unplug the D-CAL unit and move onto the next unit.

Approvals

EUROPEAN DIRECTIVES



Low voltage Directive (LVD) 2006/95/EC
Compliant to LVD

Pressure Equipment Directive (PED) 97/23/EC:

This product has a process connection size \leq DN25 and is therefore categorised as sound engineering practice under Cat 3.3

CENELEC / INTERTEK / ATEX



Intrinsically Safe:

Certificate No. ITS03ATEX21213X
EN60079-0 & EN60079-11 & EN 60079-26

For Zone 1 models (**Enclosure code 4, see Table 1**)

II 2 Ga Ex ia IIC T4 (Tamb -20°C to +80°C) Gb

Flameproof/Waterproof:

Certificate No ITS03ATEX11187 Issue 2
EN50 014 & EN50 018

For Zone 1 models (**Enclosure code R, see Table 1**)

II 2 G Ex d IIC T4 @ -40°C to +85°C (for Blind Instruments)
Ex d IIC T6 @ -40°C to +60°C (for Blind Instruments)
 II 2 G Ex d IIB + H₂ T6 @ -40°C to +60°C (for Indicating Instruments)
Ex d IIB + H₂ T6 @ -40°C to +85°C (for Indicating Instruments)

Dimensions

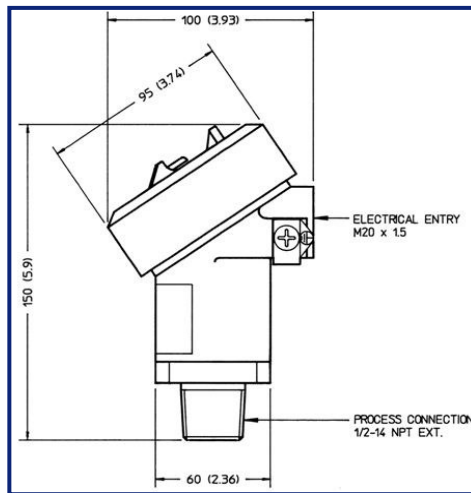

All dimensions mm (Inches)

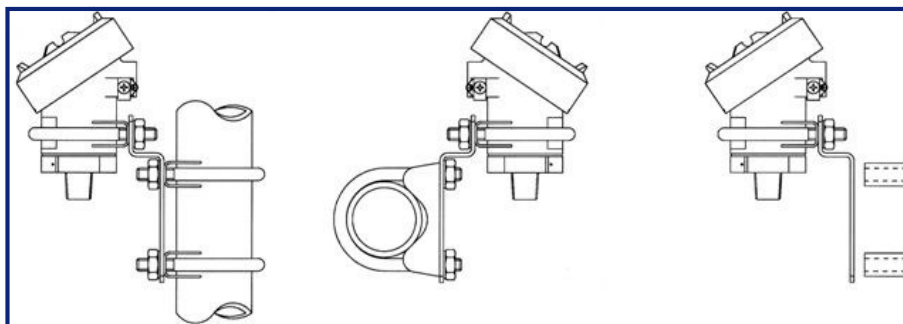

Mounting Brackets

Smart Pressure Transmitter
Model: 2HT

In the interest of development and improvement Delta Mobrey Ltd, reserves the right to amend, without notice, details contained in this publication. No legal liability will be accepted by Delta Mobrey Ltd for any errors, omissions or amendments.

Delta Mobrey Limited

Hudson House, Albany Park, Camberley, Surrey, GU16 7PL UK
T+44 (0)1252 729140 F+44 (0)1252 729168 E sales@delta-mobrey.com W www.delta-mobrey.com



ISO9001
FM00720