

Technical Datasheet



D Series

SMART Differential Pressure Transmitter

Model: D31

Key Features

- ATEX - Flameproof and Intrinsically Safe
- IECEx - Flameproof and Intrinsically Safe
- SIL 2 certificate
- Compliant to NAMUR NE-43
- High accuracy $\pm 0.075\%$ (better accuracy upon request)
- Fully HART ® compatible
- Static pressure limit up to 413 bar
- 4-20mA, 0-20mA or 0-5mA analogue with digital communications
- Gold (Au) plated diaphragm option
- Hastelloy C276 wetted parts option
- Programmable range, zero shift, characteristic and damping ratio with local panel keys
- Linearisation of output signal on 20 point curve for specific application is available
- Write protection option through DKAP-03 communicator, 'D-Soft' program or software using library EDDL

Series Overview

The D-Series pressure, differential pressure and temperature transmitters offer customers reliable and accurate solutions to their individual process requirements.

Available with a wide range of process connections and easily configurable via the D-Soft software, the D-Series can be used for a variety of applications when pressure, differential pressure, temperature, level or flow measurements are needed.

Other products in the series include:

- SMART Differential Pressure Transmitter with 2 remote chemical seals
- SMART Pressure Transmitter
- SMART Temperature Transmitter



Product applications

The D Series SMART Differential Pressure Transmitter is suitable for a wide range of applications for measuring:

- Differential Pressure
- Level
- Flow

The choice of models available ensures that the Delta Transmitter is suitable for use in:

- Corrosive atmospheres
- Resistant to chemical attack

How can we help you?

Delta Mobrey's offers fast, efficient and knowledgeable support when and where you need it. Please visit our website at www.delta-mobrey.com to find your local support centre or call us on:

+44 (0) 1252 729140

D-Series
Model: D31

How to order

Transmitters can be configured by selecting codes representing the desired features from the tables that follow. The chart below, describes how the model code is built up. For assistance in configuring a transmitter that best suits your needs, please contact your local sales office.

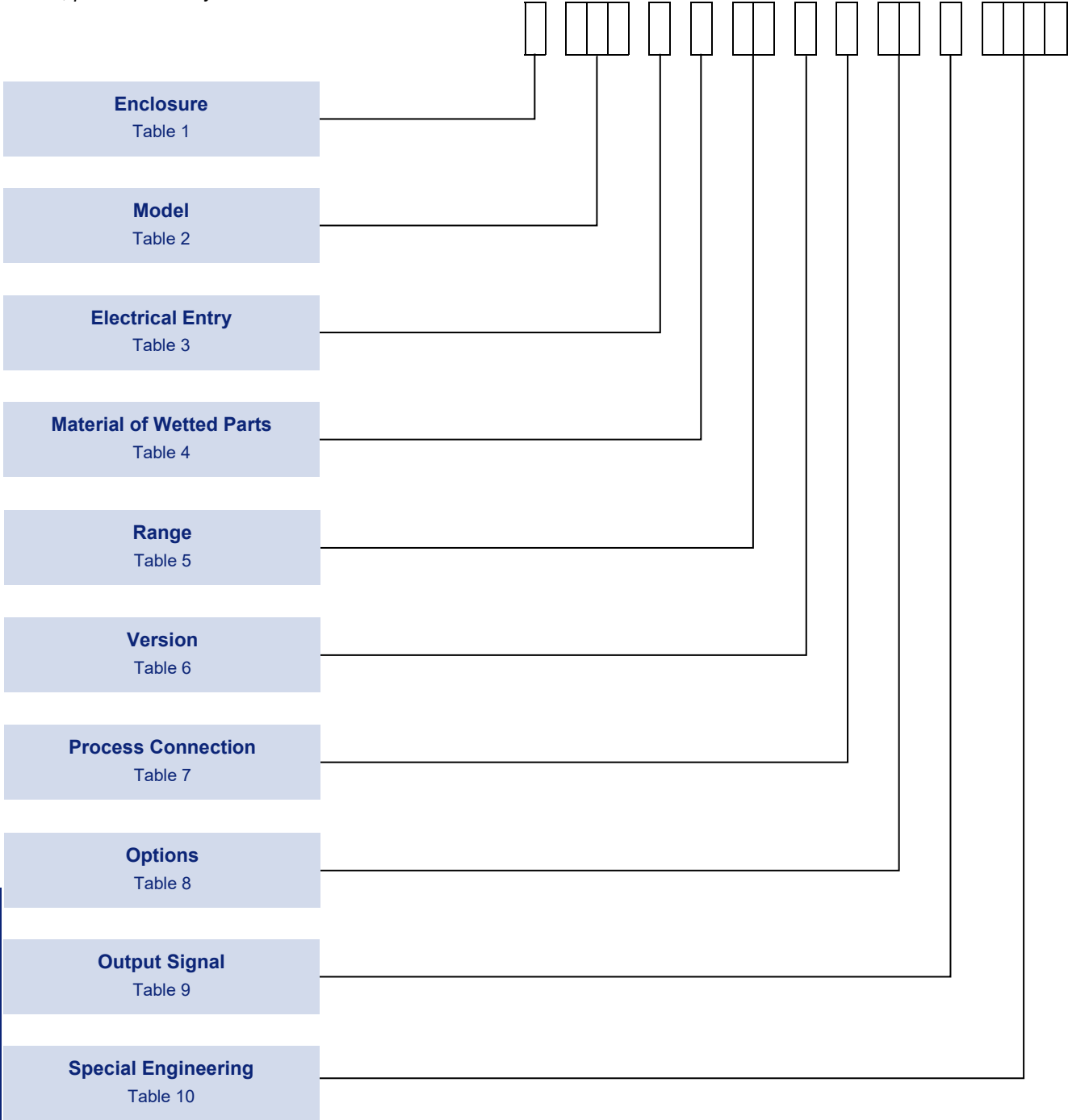

NOTE: Only the most common options are shown in this datasheet. Should you require a feature that is not shown, please contact your local sales office for further details.

NOTE: The non-standard option code is shown by "X" in the part number. Should you require any clarification on this codes please contact your local sales office.

NOTE: Please confirm before ordering if the backlight of the display is required to be settled differently from our standard. It cannot be successively settled in field.

- Instruments in Std, Exd, Exi construction are normally supplied with backlight ON.
- instruments in Safety and double certified construction, are supplied with backlight OFF

Enclosure

Note 1: Refer to the 'Approvals' section for details about the certification on Flameproof & Intrinsically Safe models .

Note 2: For both Ex-ia & Ex-d construction, the protection mode is defined by selecting on the label the correct marking, before the installation of the instrument.

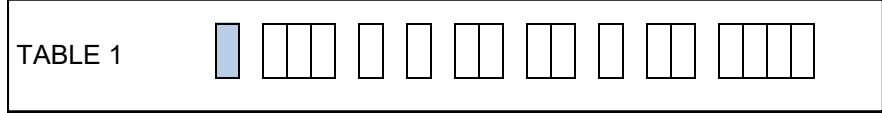

ENCLOSURES TYPES	Code
WEATHERPROOF ENCLOSURE	
General Purpose Aluminum housing, IP66, with display.	W
For Aggressive Atmosphere 316 Stainless steel housing, IP66, with display.	A
FLAMEPROOF ENCLOSURES	
Aluminum housing, IP66, with display. (Ex d) // 1/2GD -	H
316 Stainless steel housing, IP66, with display. (Ex d) // 1/2GD - I M2	R
Aluminum housing, IP66, with display. (Ex d) // G	2
316 Stainless steel housing, IP66, with display. (Ex d) // G - I M2	3
INTRINSICALLY SAFE ENCLOSURES	
Aluminum housing, IP66, with display. (Ex ia) // 1/2G	5
316 Stainless steel housing, IP66 with display. (Ex ia) // 1/2G - I M1	4
Aluminum housing, IP66, with display. (Ex ia/Da) // 1/2GD	7
316 Stainless steel housing, IP66 with display. (Ex ia/Da) // 1/2GD - I M1	6
INTRINSICALLY SAFE & FLAMEPROOF ENCLOSURES	
Aluminum housing, IP66, with display. (Ex ia / Ex d according to the installation) // 1/2GD	8
316 Stainless steel housing, IP66 with display. (Ex ia / Ex d according to the installation) // 1/2GD - I M2/M1	9

Model

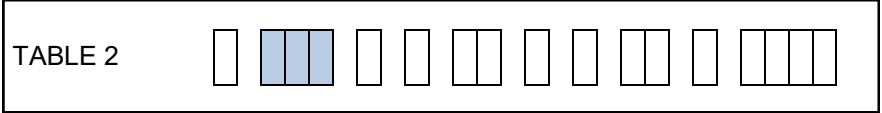

	Code
D31 SMART Differential Pressure Transmitter For applications up to 70 bar. Static pressure up to 413 bar. Refer Table 5.	D31

Electrical Entry

NOTE 1: Code 0
Available on Enclosure code H & R as standard.

NOTE 2: Code 1
Available on Enclosure code W, A, 5 & 4 as standard.

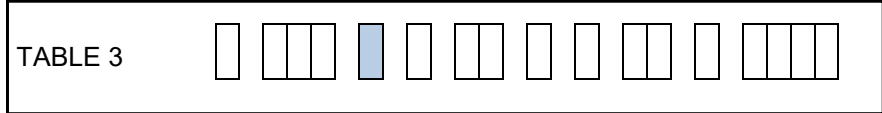

	Code
M20x1.5 thread	0
Packing gland M20x1.5	1
Electrical connection with thread 1/2NPT Female	2

D-Series
Model: D31

Process Connection

NOTE: Codes C & D
Available with NACE MR-01-75 certificate.

Note: Codes C
With M10 threaded holes according to DIN19213, Pmax is 250bar

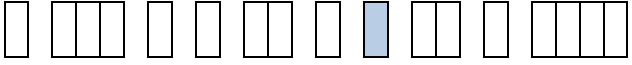
TABLE 7 

	Code
G1/2" (male)	Y
1/4" NPT Female	Q
1/4" NPT Female on the cover flanges. Cover flanges material SS316L. Allows mounting with valve manifold with M10 threaded holes	C
C type process connection rotated 90°	M
1/2" NPT Female via adaptor on the cover flanges for C type process connection. Material AISI316	N
Connection for fitting diaphragm seal (GP/PN)	9
1/4" NPT Female on the cover flanges. Cover flanges material SS316L. Allows mounting with 7/16-20 UNF threaded holes according to IEC61518	D
D type process connection rotated 90°	R

Options

Combination of more than one option is available.
(i.e. Code 35 - combination of code 30 & 50)

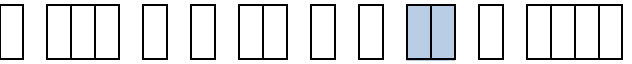
TABLE 8 

	Code
Applies when no option is required	00
Stainless Steel rating label riveted to the housing	20
Stainless Steel Tag plate mounted on wire	30
Mounting bracket for 2" pipe (only version with C-type process connection), zinc plated steel	50
Mounting bracket for 2" pipe (only version with C-type process connection), stainless steel	60
Mounting bracket for 2" pipe (only version with process connection Code P & Q), stainless steel	70
Adapter for differential pressure transmitters with C-type process connection, output thread 1/2NPT Female in SS316L	80
Connector to weld impulse pipes Ø12 and Ø14 mm, material 15HM (only version with C-type process connection)	C0
Connector to weld impulse pipes Ø12 and Ø14 mm, material 15HM(SO) or SS316(S) (only version with process connection Code P & Q)	D0

Output Signal

Note: Please refer to APPROVALS page for marking & protection.

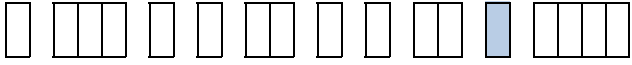
TABLE 9 

	Code
4 to 20mA (Weatherproof or Hazardous Area with ATEX marking)	0
4 to 20mA (Hazardous Area with IECEx marking only)	6
4 to 20mA (Hazardous Area with UKEx marking)	7

D-Series
Model: D31

Special Engineering

Last 4 digits of model code only used when special engineering is required.

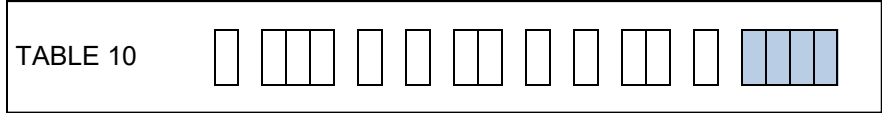

	Code
Please consult Delta Mobrey sales engineering for special require-	TBA

Application & Construction

The SMART Differential Pressure Transmitters are suitable for measuring the differential pressure of gases, vapours and liquids. The active sensing element is a piezoresistive silicon sensor separated from the medium by a diaphragm and by a specifically selected type of manometric liquid. The casing is made of cast aluminium alloy with epoxy coating or 316 stainless steel with degree of protection IP66/67. The design of the casing enables the use of a local display, rotation of the display, rotation of the casing by 0-340° relative to the sensor, and a choice of cable direction.

The communication standard for data interchange with the transmitter is the Hart protocol.

Communication with the transmitter is carried out with:

- a DKAP-03 communicator,
- some other Hart type communicators, (*)
- a PC using a HART/USB/Bluetooth converter and D-Soft configuration software

(*) .eddl file available at www.delta-mobrey.com

The data interchange with the transmitter enables the users to:

- Identify the transmitter;
- Configure the output parameters:
 - measurement units and the values of the start points and end points at the measurement range;
 - damping time constant;
 - conversion characteristic (inversion, user's non-linear characteristic);
- Read the currently measured pressure value of the output current and the percentage output control level;
- Force an output current with a set value;
- Calibrate the transmitter in relation to a model pressure

Installation

The transmitter with process connection code P or Q is not heavy with an approximate weight of 1.7kg, so it can be installed without an additional mounting bracket on application. For fitting in any desired position we recommend a universal Delta mounting bracket for 2" pipe (Refer Table 8). The version with process connections code C can be fitted directly to a 3- or 5- valve manifold. We recommend factory-mounted transmitters with VM type valve manifold. A transmitter without a valve manifold can be fitted in any position on a 2" pipe or on a wall using the C-2" mounting bracket. When the special process connections are required for the measurement of specific media levels in closed tanks (e.g. in the sugar and chemical industries), the transmitter is fitted with a Delta diaphragm seal.

Technical Data

Metrological parameters

Accuracy $\leq \pm 0.075\%$ of the calibrated range
 ($\leq \pm 0.1\%$ for range B1)
 Special Version: $\leq \pm 0.05\%$ of the calibrated range

Thermal error
 for ranges all except B1 $\leq \pm 0.05\%$ (FSO) / 10°C
 for range B1 $\leq \pm 0.08\%$ (FSO) / 10°C
 max. $\pm 0.25\%$ (FSO) in the whole compensation range
special version for all ranges except B1 $\leq \pm 0.03\%$ (FSO) / 10°C
 max. $\pm 0.1\%$ (FSO) in the whole compensation range

Thermal compensation range -25...80°C

Zero shift error for static pressure
 0.01% (FSO) / 10 bar for range A0, A1, C3, D0, D1, D2
 0.03% (FSO) / 10 bar for range B0
 0.06% (FSO) / 10 bar for ranges E0, E2
 0.01% (FSO) / 10 bar for range B0, E0 in version 2
 0.02% (FSO) / 10 bar for ranges B1

Zeroing the transmitter in conditions of static pressure can eliminate this error.

Materials

Wetted parts: code P,Q process connection: SS316L
 Code P(H),Q(H) process connection: SS316L or Hastelloy C276
 C-type process connection: SS316L

Diaphragms: SS316L, Hastelloy C 276, Au

Casing : Aluminium

Option : 316SS

Material of window: polycarbonate glass, hardened glass

Operating conditions

Operating temperature range (ambient temp.) -25...85°C
 Special version -40...85°C
 Ex ia version -25...80°C
 Ex d version -25...75°C

Process medium temperature range

-25...120°C
 over 120°C – measurement with the use of impulse line or diaphragm seals

CAUTION: The medium must not be allowed to freeze in the impulse line or close to the process connection of the transmitter.

Long-term stability \leq accuracy for 3 years
 (for the nominal measuring range) $\leq 2x$ accuracy for 5 years
 Version code 2: \leq accuracy for 6 years

Response time 16...480ms (programmable)

Additional electronic damping 0...60 s

Error due to supply voltage changes 0.002% (FSO) / V

Electrical parameters

Power supply:
 10...55 VDC / Exia: 10, 5...30 VDC / Exd: 13.5(10.5)...45 VDC
 SIL2: 15...45 VDC / SIL2 Exia: 16...28 VDC
 Special version: 12...36 VDC

Output signal 4...20 mA, two wire transmission
 Special version: 0...20 / 0...5 / 4...20 mA
 Hart Version (SIL is only 5) Ver. 5 as standard (Ver.7 on request)

$$R [\Omega] \leq \frac{U_{sup} [V] - 10V}{0.0225A}$$

Load resistance (for standard version) 0.0225A

Resistance required for communication min. 240 Ω

Accuracy depending on the set range

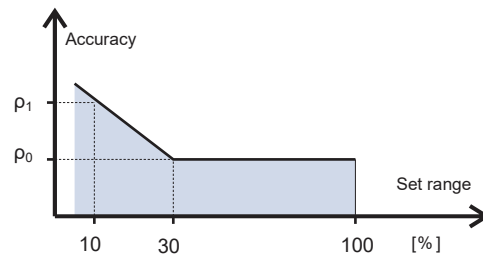

ρ_0 – error for nominal measuring range (0... 100% FSO)

ρ_1 – error for range 0... 10% FSO

$\rho_1 = 2 \times \rho_0$

Numerical error values are given in the technical data under metrological parameters

Electrical diagrams

Electrical diagrams for transmitters with HART protocol

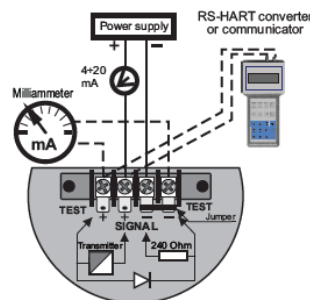

Version with output signal: 4-20mA

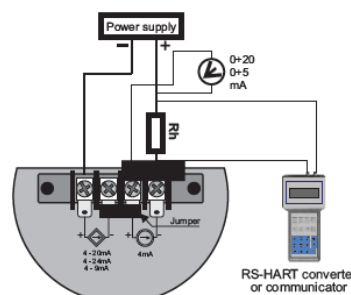

Version with output signal: 0-5mA or 0-20mA

Approvals

GLOBAL CERTIFICATION

IECEx Certified - output signal code 6 (see table 9)

INTRINSICALLY SAFE:



Certificate No.: **IECEx FTZU 15.0027X**

IEC 60079-0, IEC 60079-11,

For Zone 0/1 models

Enclosure code 7 (refer Table 1)

Ex ia IIC T4/T5 Ga/Gb

Ex ia IIIC T105°C Da (version with PTFE shielded cable)

Enclosure code 8 (refer Table 1)

Ex ia I Ma

Ex ia IIC T4/T5 Ga/Gb

Ex ia IIB T4/T5 Ga/Gb (version with PTFE shielded cable)

Certificate No.: **KDB19ATEX006X**

EN IEC 60079-0, EN 60079-11, EN 60079-26, EN 50303

For Zone 0/1,20 models

Enclosure code 5 SIL version (refer Table 1)

Ex ia IIC T4/T5 Ga/Gb

Enclosure code 4 SIL version (refer Table 1)

Ex ia I Ma

Ex ia IIC T4/T5 Ga/Gb

Enclosure code 7 (refer Table 1)

Ex ia IIC T4/T5 Ga/Gb

Ex ia IIIC T105°C Da

Enclosure code 8 (refer Table 1)

Ex ia I Ma

Ex ia IIC T4/T5 Ga/Gb

Ex ia IIIC T105°C Da

FLAMEPROOF:



Certificate No.: **IECEx KDB 19.006X**

IEC 60079-0, IEC 60079-1, IEC 60079-11, IEC 60079-26, IEC 60079-31

For Zone 0/1, 20/21 models

Enclosure code H (refer Table 1)

Ex ia/db IIC T6/T5 Ga/Gb

Ex ia/tb IIIC T105°C Da/Db

Enclosure code R (refer Table 1)

Ex db ia I Mb

Ex ia/db IIC T6/T5 Ga/Gb

Ex ia/tb IIIC T105°C Da/Db

For Zone 1, 21 models

Enclosure code 2 (refer Table 1)

Ex ia/db IIC T6/T5 Gb

Ex ia/tb IIIC T105°C Db

Enclosure code 3 (refer Table 1)

Ex db ia I Mb

Ex ia/db IIC T6/T5 Gb

Ex ia/tb IIIC T105°C Db

INTRINSICALLY SAFE & FLAMEPROOF (*):

(* According to the selection on the label)



Certificate No.: **IECEx KDB 19.0006X**

IEC 60079-0, IEC 60079-1, IEC 60079-11, IEC 60079-26, IEC 60079-31

For Zone 0/1, 20/21 or 0/1, 20 models

Enclosure code 8 (refer Table 1)

Ex ia/db IIC T6/T5 Ga/Gb

Ex ia/tb IIIC T105°C Da/Db

Or

Ex ia IIC T5/T4 Ga/Gb

Ex ia IIIC T105°C Da

Enclosure code 9 (refer Table 1)

M2 Ex db ia I Mb

Ex ia/db IIC T6/T5 Ga/Gb Ex ia/tb IIIC T105°C Da/Db

Or

Ex ia I Ma

Ex ia IIC T5/T4 Ga/Gb

Ex ia IIIC T105°C Da

Functional Safety Certified

Meets the requirements of IEC 61508: 2010 part 1-7 ; IEC 61511-1:2016+IEC 61511-1:2016/AMD1:2017 IEC 62061:2005 + IEC 62061:2005/AMD1:2012 + IEC 62061:2005/AMD2:2015 for use in safety related systems.

Systematic capability: SC 3;

SIL2 @ HFT 0; Route 1_H

SIL3 @ HFT 1; Route 1_H

Certificate No. UDT-CERT No.1005/CW/001



Approvals

EUROPEAN DIRECTIVE)

ATEX Directive 2014/34/EU - output signal code O (see table 9)

INTRINSICALLY SAFE:



Certificate No.: **FTZU 19ATEX0111X**
EN IEC 60079-0, EN 60079-11, EN 50303

For Zone 0/1 models



Enclosure code 5 (refer Table 1)
II 1/2G Ex ia IIC T4/T5 Ga/Gb
II 1D Ex ia IIIC T105°C Da (version with PTFE shielded cable)

Enclosure code 4 (refer Table 1)
I M1 Ex ia I Ma
II 1/2G Ex ia IIC T4/T5 Ga/Gb
II 1D Ex ia IIIC T105°C Da (version with PTFE shielded cable)

Certificate No.: **KDB19ATEX0045X**
EN IEC 60079-0, EN 60079-11, EN 60079-26, EN 50303

For Zone 0/1,20 models

Enclosure code 5 SIL version (refer Table 1)
II 1/2G Ex ia IIC T4/T5 Ga/Gb

Enclosure code 4 SIL version (refer Table 1)

I M1 Ex ia I Ma
II 1/2G Ex ia IIC T4/T5 Ga/Gb

Enclosure code 7 (refer Table 1)
II 1/2G Ex ia IIC T4/T5 Ga/Gb
II 1D Ex ia IIIC T105°C Da

Enclosure code 8 (refer Table 1)
I M1 Ex ia I Ma
II 1/2G Ex ia IIC T4/T5 Ga/Gb
II 1D Ex ia IIIC T105°C Da

FLAMEPROOF:



Certificate No.: **KDB19ATEX0045X**
EN IEC 60079-0, EN 60079-1, EN 60079-11, EN 60079-26, EN 60079-31, EN50303

For Zone 0/1, 20/21 models



Enclosure code H (refer Table 1)
II 1/2G Ex ia/db IIC T6/T5 Ga/Gb
II 1/2D Ex ia/tb IIIC T105°C Da/Db

Enclosure code R (refer Table 1)
I M2 Ex db ia I Mb
II 1/2G Ex ia/db IIC T6/T5 Ga/Gb
II 1/2D Ex ia/tb IIIC T105°C Da/Db

For Zone 1, 21 models

Enclosure code 2 (refer Table 1)
II 2G Ex ia/db IIC T6/T5 Gb
II 2D Ex ia/tb IIIC T105°C Db

Enclosure code 3 (refer Table 1)
I M2 Ex db ia I Mb
II 2G Ex ia/db IIC T6/T5 Gb
II 2D Ex ia/tb IIIC T105°C Db

INTRINSICALLY SAFE & FLAMEPROOF (*):

(*): According to the selection on the label



Certificate No.: **KDB19ATEX0045X**
EN IEC 60079-0, EN 60079-1, EN 60079-11, EN 60079-26, EN 60079-31, EN50303

For Zone 0/1, 20/21 or 0/1, 20 models



Enclosure code 8 (refer Table 1)
II 1/2G Ex ia/db IIC T6/T5 Ga/Gb
II 1/2D Ex ia/tb IIIC T105°C Da/Db
or

Enclosure code 9 (refer Table 1)
M2 Ex db ia I Mb
II 1/2G Ex ia/db IIC T6/T5 Ga/Gb
II 1/2D Ex ia/tb IIIC T105°C Da/Db
or

II 1/2G Ex ia IIC T5/T4 Ga/Gb
II 1D Ex ia IIIC T105°C Da

I M1 Ex ia I Ma
II 1/2G Ex ia IIC T5/T4 Ga/Gb
II 1D Ex ia IIIC T105°C Da



EMC Directive 2014/30/EU

Conformity assessment procedure: module A
The following standards were applied: EN 61326-1:2013; EN61326-2-3:2013

2014/68/EU Pressure Equipment Directive

For Nameplate Parameter **PS>200 bar**: The transmitters in PED version according to Module A of Directive 201/68/EU have specified on the nameplate parameters PS>200bar, P(range).....T(amb.).....

For Nameplate Parameter **PS< 200bar**, P(range).....T(amb.).... are manufactured on the basis of Article 4, Clause 3 of Directive 2014/68/EU in accordance with the sound engineering practice

Restriction of hazardous substances (RoHS 2) 2011/65/EU

Compliant to RoHS. The following standard was applied: EN IEC 63000:201

Approvals

UK REGULATIONS

Equipment and Protective Systems Intended for use in Potentially Explosive Atmospheres Regulations 2016

Output signal code 7 (see table 9)

INTRINSICALLY SAFE:



Certificate No.: **ExVeritas 22UKEX1416X**
EN IEC 60079-0, EN 60079-11, EN60079-26 , EN 50303

For Zone 0/1, 20 models



Enclosure code 5 SIL version (refer Table 1)

II 1/2G Ex ia IIC T4/T5 Ga/Gb

Enclosure code 7 (refer Table 1)

II 1/2G Ex ia IIC T4/T5 Ga/Gb

II 1D Ex ia IIIC T105°C Da

Enclosure code 4 SIL version (refer Table 1)

I M1 Ex ia I Ma

II 1/2G Ex ia IIC T4/T5 Ga/Gb

Enclosure code 8 (refer Table 1)

I M1 Ex ia I Ma

II 1/2G Ex ia IIC T4/T5 Ga/Gb

II 1D Ex ia IIIC T105°C Da

FLAMEPROOF:



Certificate No.: **22UKEX1416X**
EN IEC 60079-0, EN 60079-1, EN 60079-11, EN 60079-26, EN 60079-31, EN50303

For Zone 0/1, 20/21 models



Enclosure code H (refer Table 1)

II 1/2G Ex ia/db IIC T6/T5 Ga/Gb

II 1/2D Ex ia/tb IIIC T105°C Da/Db

For Zone 1, 21 models

Enclosure code 2 (refer Table 1)

II 2G Ex ia/db IIC T6/T5 Gb

II 2D Ex ia/tb IIIC T105°C Db

Enclosure code R (refer Table 1)

I M2 Ex db ia I Mb

II 1/2G Ex ia/db IIC T6/T5 Ga/Gb

II 1/2D Ex ia/tb IIIC T105°C Da/Db

Enclosure code 3 (refer Table 1)

I M2 Ex db ia I Mb

II 2G Ex ia/db IIC T6/T5 Gb

II 2D Ex ia/tb IIIC T105°C Db

INTRINSICALLY SAFE & FLAMEPROOF (*):

(*) According to the selection on the label



Certificate No.: **22UKEX1416X**
EN IEC 60079-0, EN 60079-1, EN 60079-11, EN 60079-26, EN 60079-31, EN50303

For Zone 0/1, 20/21 or 0/1, 20 models



Enclosure code 2 (refer Table 1)

II 1/2G Ex ia/db IIC T6/T5 Ga/Gb

II 1/2D Ex ia/tb IIIC T105°C Da/Db

or

II 1/2G Ex ia IIC T5/T4 Ga/Gb

II 1D Ex ia IIIC T105°C Da

Enclosure code 3 (refer Table 1)

M2 Ex db ia I Mb

II 1/2G Ex ia/db IIC T6/T5 Ga/Gb

II 1/2D Ex ia/tb IIIC T105°C Da/Db

or

I M1 Ex ia I Ma

II 1/2G Ex ia IIC T5/T4 Ga/Gb

II 1D Ex ia IIIC T105°C Da

Dimensions

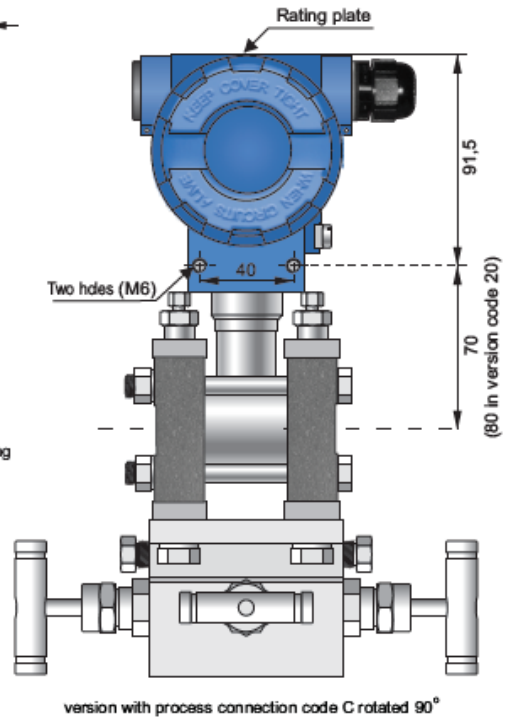
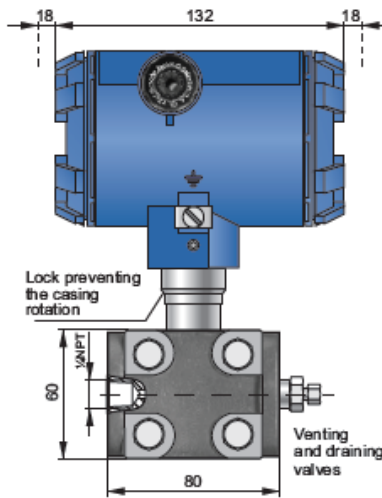
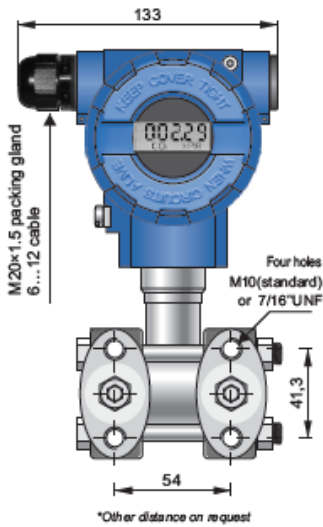

SMART Differential Pressure Transmitter
version with process connection Code C to be mounted together with valve manifold

version with process connection code C rotated 90°

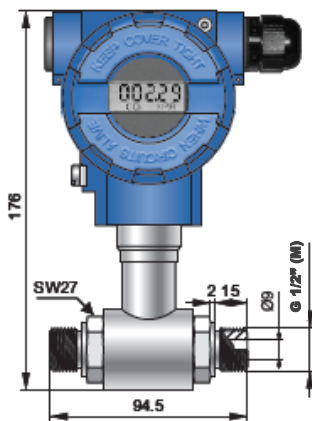

SMART Differential Pressure Transmitter
version with process connection : Code Y

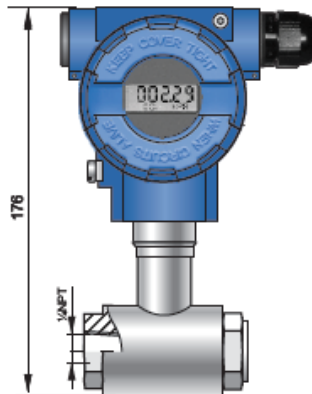

SMART Differential Pressure Transmitter
version with process connectio : Code Q

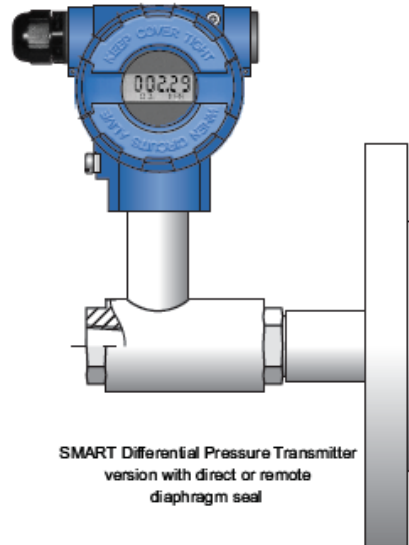

SMART Differential Pressure Transmitter
version with direct or remote
diaphragm seal

Figure 1
(All dimensions in mm)

WEIGHT

Model	Weight
D31 / Connection C	3.6 kg
D31 / Connection Y,Q	1.7 kg

Weight may varies with different process connections.

In the interest of development and improvement Delta Mobrey Ltd, reserves the right to amend, without notice, details contained in this publication. No legal liability will be accepted by Delta Mobrey Ltd for any errors, omissions or amendments.

Delta Mobrey Limited

Hudson House, Albany Park Camberley Surrey, GU16 7PL, UK.

T+44 (0)1252 729140 F+44 (0)1252 729168 E sales@delta-mobrey.com W www.delta-mobrey.com

D-Series
Model: D31

