

# Technical Datasheet



## Magnetic Horizontal Level Switches For Hazardous areas



### Key Features

- Operates in almost every liquid at high pressure or temperature
- Tough, rugged design for long life in aggressive environments
- Magnetically coupled
- No glands or linkages that could cause leaks



### Series Overview

The Mobrey magnetic horizontal float switch is ideal for high and low liquid level alarm, and pump control duties. It is designed to open or close a circuit as a changing liquid level within a vessel passes the level of the float.

When the process liquid level is below the switch point, contacts B-B are made and contacts A-A are open, but if the liquid level is above the switch point, contacts A-A are made and contacts B-B are open.

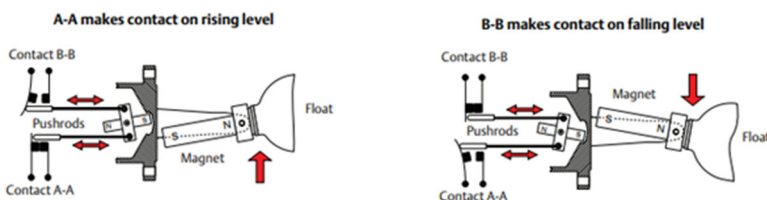

### Product applications

- High and low liquid level alarm
- Direct (side or top) or chamber mounting
- Pump control duty
- Interface duty
- Can be fitted to Zone 0 vessels with process temperatures up to 400°C.

### Other products

Other products we can offer :

- Vertical level switches



### How can we help you?

Delta Mobrey offers fast, efficient and knowledgeable support when and where you need it. Please visit our website at [www.delta-mobrey.com](http://www.delta-mobrey.com) to find your local support centre or call us on:

**+44 (0)1252 729140**

# How to order

Instrument can be configured by selecting codes representing the desired features from the tables that follow.

The chart below, describes how the model code is built up. For assistance in configuring a switch that best suits your needs, please contact your local sales office.

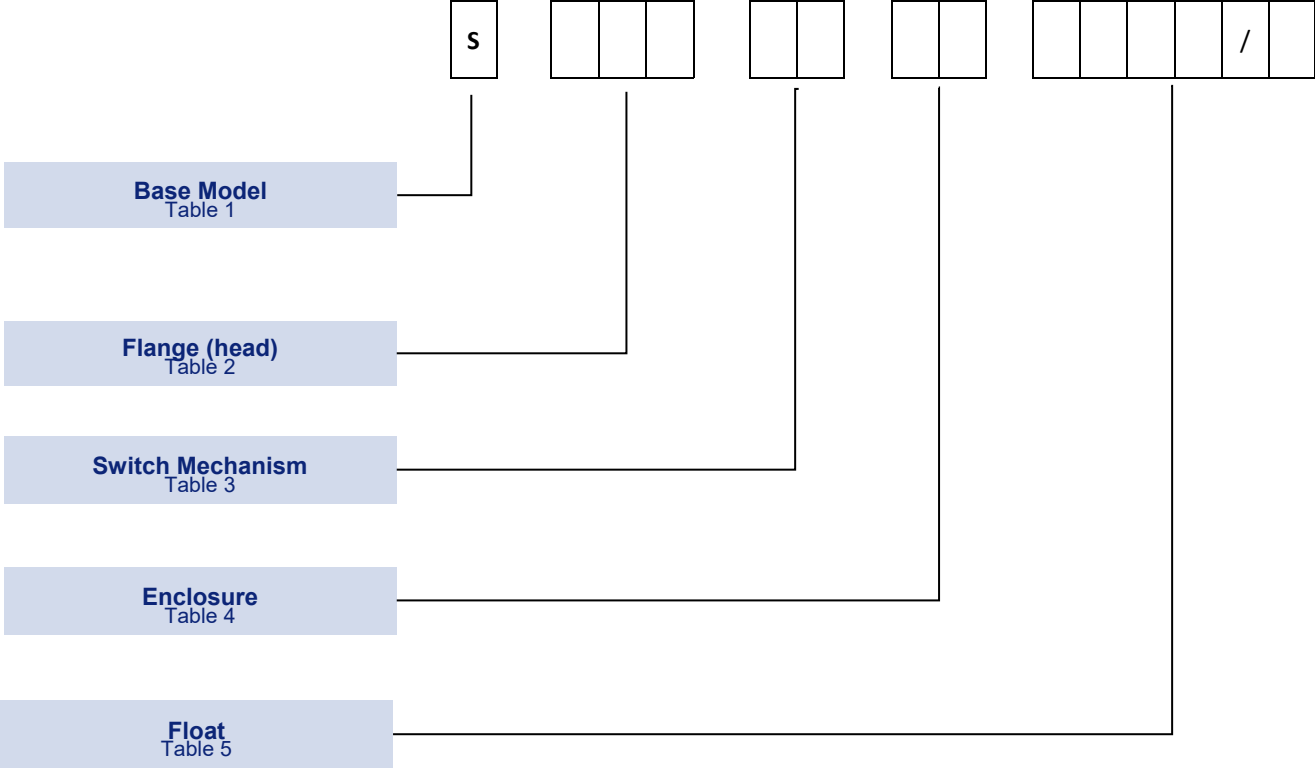



**Switch Mechanism <sup>(5)</sup>**

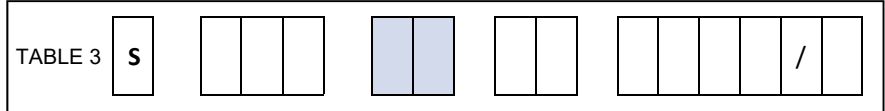

Description	Max T Process <sup>(2)</sup>	Code
Electrical: 2 independent Single Pole Single Throw (SPST) contact sets	752 °F (400 °C)	D
As type D but with gold plated contacts	752 °F (400 °C)	P
Electrical: 2 independent circuits of Double Pole Double Throw (DPDT) contact sets	752 °F (400 °C)	D6
As type D6 but with gold plated contacts	752 °F (400 °C)	P6
As type D6 but with gold plated contacts and hermetically sealed moving parts	482 °F (250 °C)	H6

**Switch Enclosure**

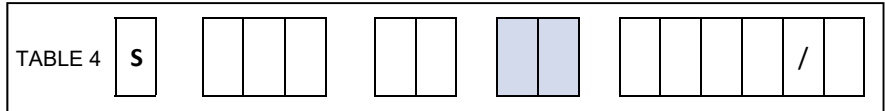

Description	Max T Process <sup>(2)</sup>	Code
Aluminium alloy	752 °F (400 °C)	A
Gunmetal	662 °F (350 °C)	G
Aluminium alloy, low ambient temperatures -4 to -76 °F (-20 to -60 °C)	752 °F (400 °C)	AX <sup>(6)</sup>
Gunmetal, low ambient temperatures -4 to -76 °F (-20 to -60 °C)	662 °F (350 °C)	GX <sup>(6)</sup>

**Float (All ratings at T room) <sup>(7)</sup>**

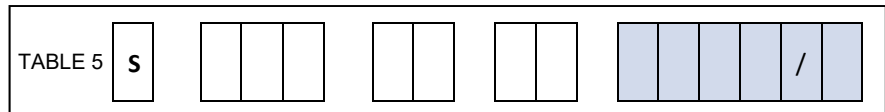

Description	Switch type	Code
General purpose high/low alarm, 316 SST, min. SG 0.65, 500 psi (34.5 bar)	All	F84
Horizontal variable differential for pump control/alarm, 316 SST, min. SG 0.72, 500 psi (34.5 bar)	All	F68/1 <sup>(8)</sup>
Horizontal variable differential for pump control/alarm, 316 SST, min. SG 0.85, 500 psi (34.5 bar)	All	F68/4 <sup>(8)</sup>
Vertical pump control or alarm, 316 SST, rod length 1524mm, 435 psi (30 bar)	All	F21/1 <sup>(8)</sup>

Magnetic Horizontal Level Switches

Model: Hazardous areas

Vertical pump control or alarm, 316 SST, rod length 3048mm, 435 psi (30 bar)	All	F21/2 <sup>(8)</sup>
Vertical pump control or alarm, 316 SST, rod length 4570mm, 435 psi (30 bar)	All	F21/3 <sup>(8)</sup>
Straight arm, 316 SST, rod length 750mm, 500 psi (34.5 bar)	All	F104/1 <sup>(8)</sup>
Cranked arm, horizontal, 316 SST, dimensions to be specified, 500 psi (34.5 bar)	All	F104/2 <sup>(8)</sup>
Cranked arm, vertical, 316 SST, dimensions to be specified, 500 psi (34.5 bar)	All	F104/3 <sup>(8)</sup>
General purpose high/low alarm, Alloy 400, min. SG 0.65, 500 psi (34.5 bar)	All	F185
General purpose high/low alarm, 316 SST, min. SG 0.60, 1073 psi (74 bar)	All	F96
General purpose high/low alarm, 316 SST, min. SG 0.45, 500 psi (34.5 bar)	All	F98
General purpose high/low alarm, 316 SST, min. SG 0.51, 1073 psi (74 bar)	All	F106
General purpose high/low alarm, 316 SST, min. SG 0.71, 2900 psi (200 bar)	All	F107
Interface duties, 316 SST, min. SG 0.80, 1073 psi (74 bar)	All	F88
Horizontal limited differential, Alloy 400, min. SG 0.85, 464 psi (32 bar)	All	F264

1. See page 11 for nozzle and stud lengths.
2. The maximum allowed process temperature is dependent on the Flange (Head), Switch mechanism, Enclosure/Housing, and Float options chosen.
3. There is no back flange fitted to the S250 and S275 flange (head).
4. See page 9 for Mobrey flange information.
5. See "Switch mechanism specifications" on page 8 for information about all switch mechanisms.
6. The ATEX certification covering  $-4$  to  $-76$  °F ( $-20$  to  $-60$  °C) requires Mechanism Switch code H6 to be selected.
7. See page 11 for a comparison of the float options listed here.
8. See pages 11,12,13 and 14 for technical float details and length options.

## Float switch specifications

**Table 6. Float Switch Specification - Hazardous Area Applications**

General	
Enclosure/Housing materials	Aluminium alloy to BS 1490: grade LM24, nickel-plated. All external aluminium surfaces are chromate phosphate treated, and then externally stove painted  Gunmetal to BS1400: LG2 Nickel-plated finish
IP rating	Weatherproof to IEC60529 (IP66)
Wetside material	316 Stainless steel to Mobrey Standard (316S33 Stainless steel for S260 and S261 switches)  Gunmetal to BS1400: LG2
Back flange (excludes S250 and S275)	Carbon steel to BS 1501: 224 Grade 430B LT50  This material has guaranteed properties at high (752 °F/400 °C) and low (–58 °F/–50 °C) temperatures
Maximum process temperatures	Aluminium enclosure: 752 °F (400 °C); Gunmetal enclosure: 662 °F (350 °C) Note: See “Gasket Material” below for gasket temperature limits  S275: 392 °F (200 °C)
Gasket material	Float switches with AMSE B16.5 Class 600, Class 900, or EN 1092-1 PN 63 flanges are fitted with spiral wound non-asbestos filled gaskets rated to 752 °F (400 °C)  Otherwise non-asbestos sheet material gaskets to BS 7531 Grade X, which has upper temperature limits of 482 °F (250 °C) for gas, vapor, and steam, and 440 °C for liquids. If the switch experiences gas vapor or steam temperatures above 482 °F (250 °C), then a suitable alternative gasket must be fitted
Ambient temperatures below 0 °C	(i) Down to –4 °F (–20 °C) Standard enclosure/housing codes A or G are suitable  (ii) Down to –76 °F (–60 °C)  Specify Enclosure/Housing order codes “AX” or “GX” which are as standard but with ATEX certification to use down to –76 °F (–60 °C). Note: This is downrated to –58 °F (–50 °C) unless a Mobrey ‘G’ flange is fitted or low temperature back flange is specified
Dimensions	See page 9 for dimensional drawings
Approvals <sup>(1)</sup>	
ATEX	II 1/2 G, Ex db IIC T6...T1 Ga/Gb (Ta = –20 °C to 60 °C) Housing code AX or GX II 1/2 G, Ex db IIC T6...T1 Ga/Gb (Ta = –60 °C to 60 °C)
IECEX	Ex db IIC T6...T1 Ga/Gb (Ta = –20 °C to 60 °C) Housing code AX or GX, Ex db IIC T6...T1 Ga/Gb (Ta = –60 °C to 60 °C)
CSA <sup>(2)</sup>	Canadian Standards Association, Class 1: Group CD
Marine	Lloyds Register of Shipping (LRS)

1. Other approvals maybe available. Please contact a Delta Mobrey representative for additional information.

2. CSA certified products are available to special order.

**Table 7. Electrical switch mechanism specification**

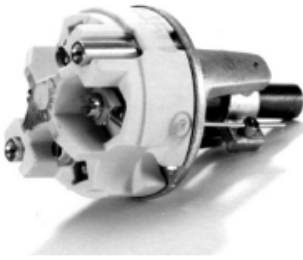
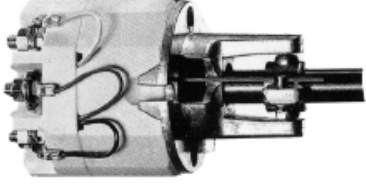
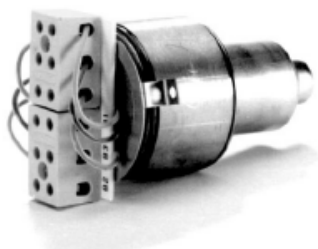
Electrical type D and P	Electrical type D6 and P6	Electrical type H6
		
<b>Electrical switch mechanism</b>		
<p><b>Type D</b></p> <ul style="list-style-type: none"> <li>• For alternative make and break circuits</li> <li>• Function: 2 independent Single Pole Single Throw contacts sets and “snap-action”</li> <li>• May be wired S.P.C.O. on site</li> </ul>		
<p><b>Type D6</b></p> <ul style="list-style-type: none"> <li>• For switching two independent circuits</li> <li>• Function Double Pole change over (2 independent circuits) and “snap-action”</li> </ul>		
<p><b>Type P and P6</b></p> <ul style="list-style-type: none"> <li>• As type D and D6 but with Gold Plated Contacts for switching low power (e.g. Intrinsically Safe) electrical circuits</li> </ul>		
<p><b>Type H6</b></p> <ul style="list-style-type: none"> <li>• For use in corrosive area and/or low temperature applications</li> <li>• As type D6 but with Gold Plated Contacts and housed in an Inert Gas filled, Hermetically sealed enclosure</li> </ul>		

**Figure 1. Electrical Switching**

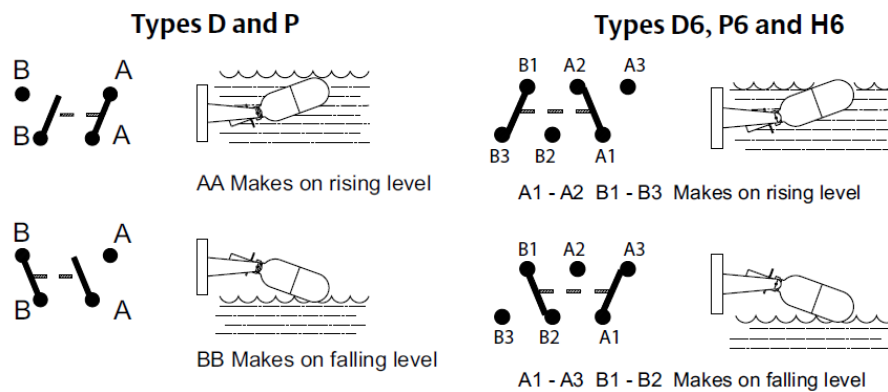

**Table 8. Electrical switch mechanism specifications**

Electrical switch specification	D and D6	P and P6	H6
Contact material	Fine silver	Gold plated	Gold plated
Process temperature	-22 to 752 °F (-30 to 400 °C)	-22 to 752 °F (-30 to 400 °C)	-148 to 482 °F (-100 to 250 °C)
Ambient temperature	-22 to 158 °F (-30 to 70 °C)	-22 to 158 °F (-30 to 70 °C)	-76 to 158 °F (-60 to 70 °C)
Insulation value	(live to earth) > 100 MEG OHM		
Terminals	D and P: M4 screws with non-rotational clamp plates.		
	D6 and P6, : 6-way terminal block with pressure plates		
Electrical specification	AC	DC Inductive	DC resistive
Maximum voltage V	440	240	240
Maximum current A	5.0 <sup>(1)</sup>	1.0	2.0
Maximum power	2000VA	35 Watts	70 Watts
	Power factor 0.4, minimum	Time constant 40 ms, maximum	

1. Maximum current for Type D is 8 A up to 410°F (210°C).

**Warning**

The plating of gold contacts may be permanently damaged when used to switch circuits above the following limits:

- 300 V: 12 mA Resistive
- 24 V: 2 mH/200 mA Inductive
- 24 V: 250 mA Resistive
- 24 V: 750 mH/10 mA Inductive

**Note**

LVD (Low Voltage Directive) standards applied: EN60947 Parts 1 and 5.1

**Dimensional Drawings**

Mobrey 'G' flange

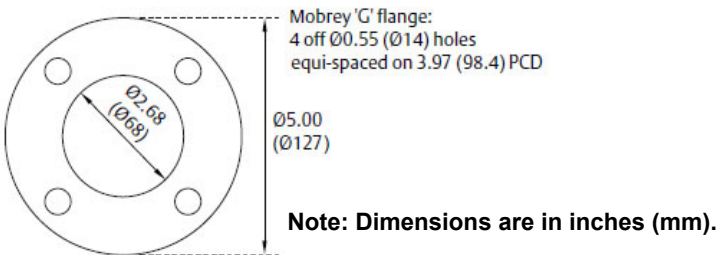

**Hazardous area float switches**

**Note: See Table 9 for dimensions X, Y and Z**

**Note: Dimensions are in inches (mm).**

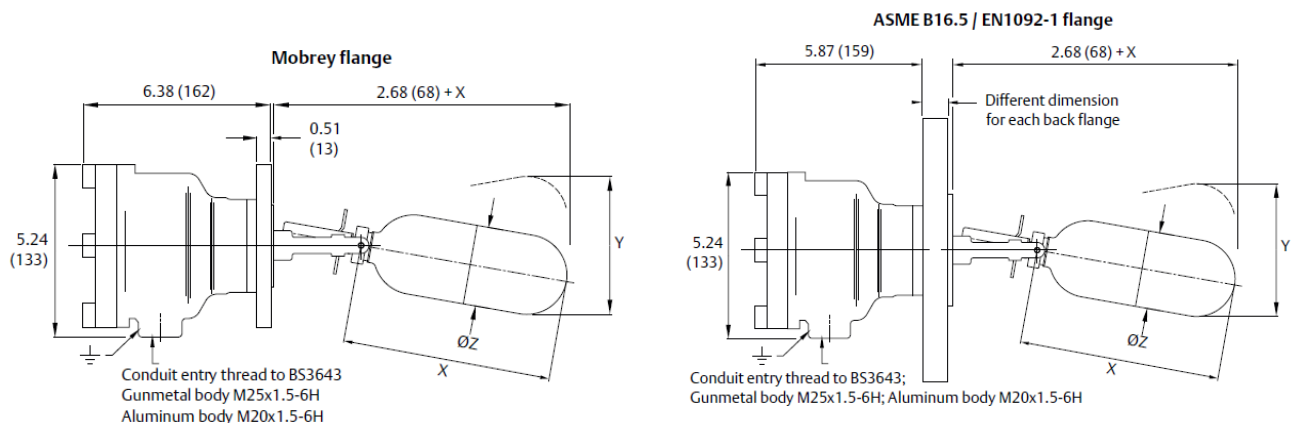

Magnetic Horizontal Level Switches  
Model: Hazardous areas



## Pressure/Temperature Relationships

The graphs below show the maximum allowable working pressure of our float assemblies and process connection flanges across their working temperature range.

### Stainless Steel Wetside Switches

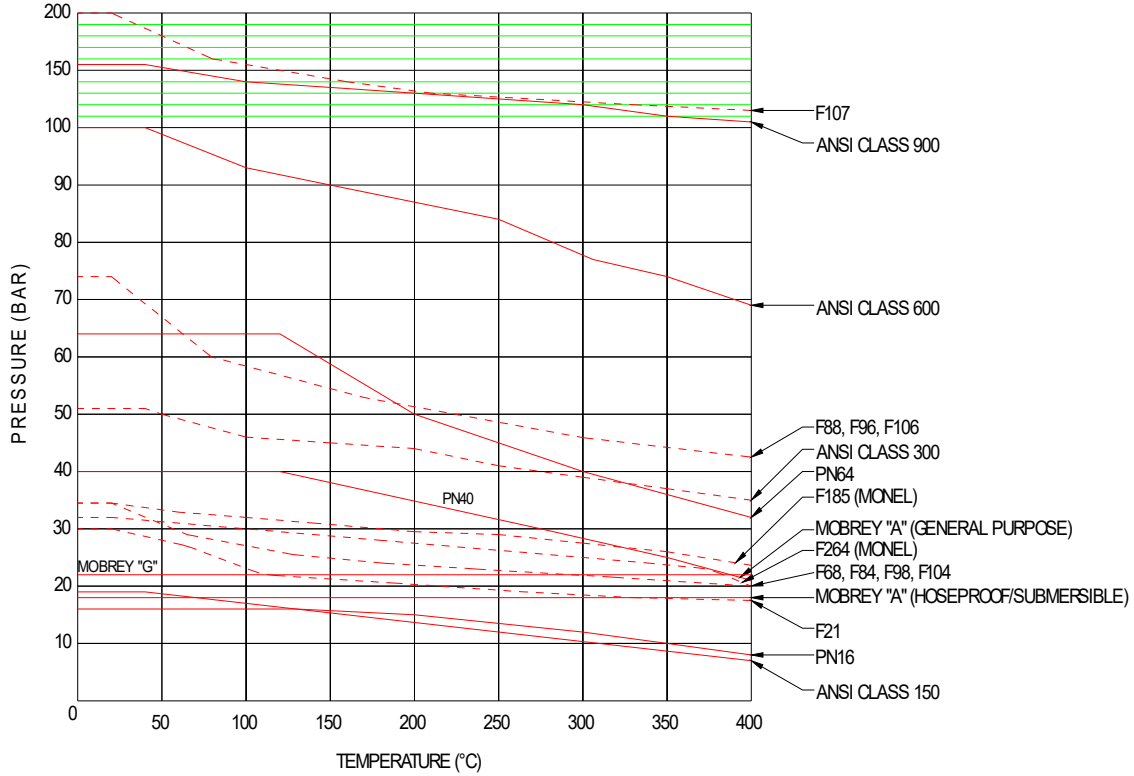

F93 WORKING PRESSURE: LIMITED TO ATMOSPHERIC UP TO 180°C

### Non-Ferrous Wetside Switches

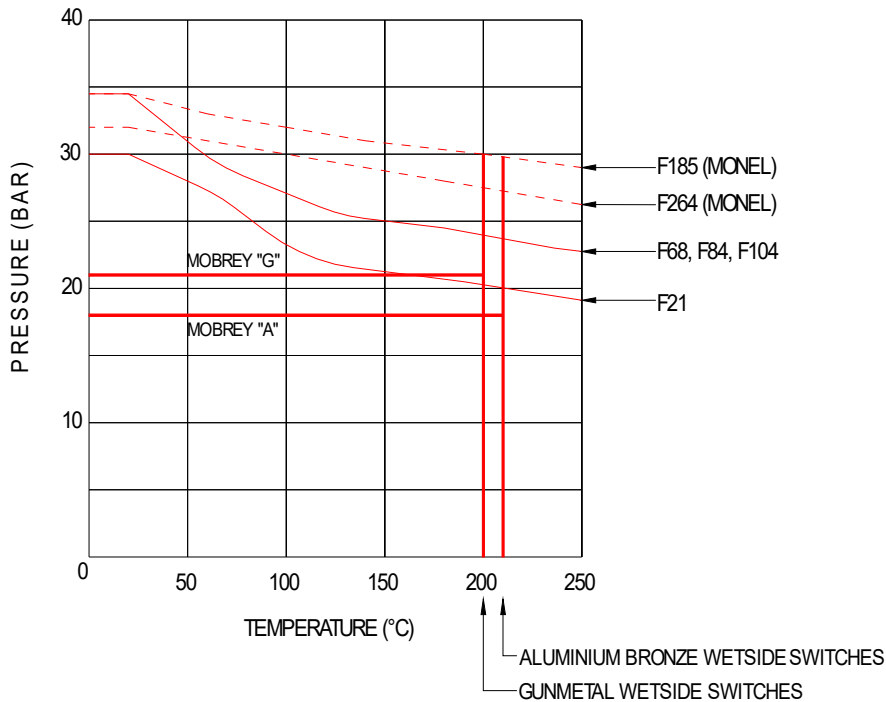

F93 WORKING PRESSURE: LIMITED TO ATMOSPHERIC UP TO 180°C

Magnetic Horizontal Level Switches  
Model: Hazardous areas

**Table 9. Float dimensions X, Y, and Z hazardous area Float**

Float Type	Minimum S.G.	Max. P@T Room PSI (Bar)	Max. T Process °F (°C)	Differential in. (mm)	Dimension X in. (mm)	Dimension Y in. (mm)	Dimension ØZ in. (mm)	Float Material
F84	0.65	500 (34.5)	752 (400)	0.51 (13)	6.45 (164)	4.68 (119)	2.56 (65)	316 SST
F96	0.60	1073 (74)	752 (400)	0.51 (13)	6.45 (164)	4.68 (119)	2.56 (65)	316 SST
F98	0.45	500 (34.5)	752 (400)	0.55 (14)	7.24 (184)	5.00 (127)	2.56 (65)	316 SST
F106	0.51	1073 (74)	752 (400)	0.51 (13)	7.28 (185)	4.25 (108)	2.56 (65)	316 SST
F107	0.71	2900 (200)	752 (400)	0.51 (13)	6.77 (172)	4.72 (120)	2.46 (62.5)	316 SST
F68/+( <sup>1</sup> )	0.72 to 0.85	500 (34.5)	752 (400)	Variable (See page 12)			2.56 (65)	316 SST
F21/+( <sup>1</sup> )	0.70	435 (30)	752 (400)	Variable (See page 12)			5.08 (129)	316 SST
F104/+( <sup>1</sup> )	Various	500 (34.5)	752 (400)	As Ordered (See page 13)			2.56 (65)	316 SST
F88	0.8/1.0	1073 (74)	752 (400)	1.02 (26)	14.13 (359)	7.79 (198)	2.56 (65)	316 SST
F185	0.67	500 (34.5)	752 (400)	0.51 (13)	6.45 (164)	4.68 (119)	2.56 (65)	Alloy 400
F264	0.85	464 (32.0)	752 (400)	0.9 (23)/1.14 (29)/1.3 (33)	7.05 (179)	Variable	2.56 (65)	Alloy 400

1. Refer to pages 11, 12, 13 and 14 for technical float details and length options. See “Nozzle and stud lengths” below for stud lengths.

**Nozzle and stud lengths**

**Table 10. Maximum Length in mm (Dimension L)**

	F68/*	F84	F185	F88	F93	F96	F98	F107	F106	F264
<b>Mobrey A</b>	65	75	75	135	75	75	90	-	92	75
<b>DN65</b>	65	75	75	135	-	75	90	-	92	75
<b>DN80</b>	70	80	80	170	-	75	90	-	98	90
<b>DN100</b>	95	105	105	200	-	105	105	-	110	100
<b>DN125</b>	105	140	140	200	-	140	140	-	140	140
<b>DN150</b>	224	180	180	200	-	180	170	-	200	190
<b>3 in. 300/150</b>	70	80	80	170	-	80	90	-	98	90
<b>4 in. 300/150</b>	95	105	105	200	-	105	105	-	110	100
<b>3 in. 600</b>	62	70	70	130	-	70	85	80	89	70
<b>3 in. 900</b>	-	-	-	-	-	70	-	80	-	-
<b>Mobrey G</b>	65	75	75	135	-	75	90	-	92	75
<b>6 in. 150</b>	224	180	180	200	-	180	170	-	200	190

**Note**

See figure 4 on page 15 for companion flanges and accessories.

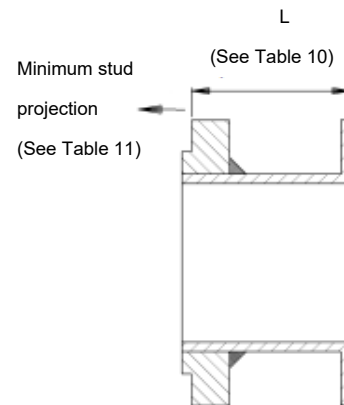

**Table 11. Minimum stud projection (in mm)**

Rating	G	A	PN 16					PN 40					PN 63				150		300		600	900
<b>Size</b>	-	-	65	80	100	125	150	65	80	100	125	150	80	100	125	150	3 in.	4 in.	3 in.	4 in.	3 in.	3 in.
<b>Stud</b>	35	30	40	40	40	40	44	42	42	46	52	54	52	55	62	67	46	56	54	56	64	73

**Horizontal F68 pump control and alarm float**

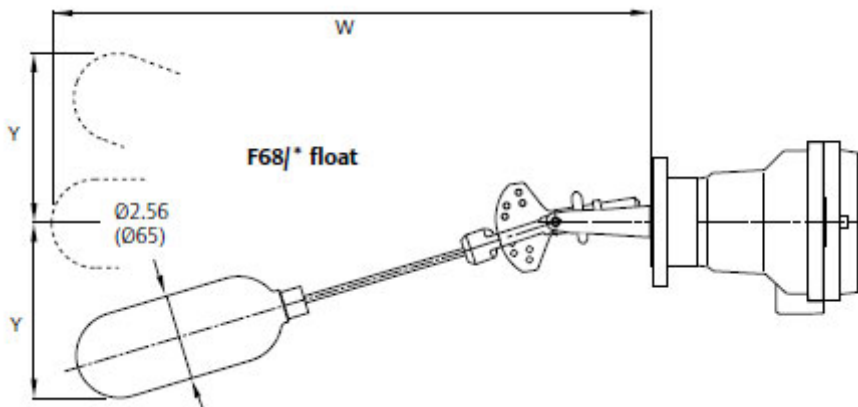

**Note: Dimensions are in inches (mm).**

**Note**

Switches fitted with the F68/+ type float may be adjusted on site to meet pump control differentials. The float is available as F68/1 or F68/4. The F68/4 has pre-drilled holes along the rod to allow the user to achieve the 1/2 and 1/3 differentials in Table 12 Full details of the operating levels and differentials are in the product manual (Document Number M310).

**Table 12. Dimensions and specifications for F68/\***

Maximum Intrusions <sup>(1)</sup>	F68/1	F68/2	F68/3	F68/4
Wetside in. (mm) 'W'	14.2 (360)	18.5 (470)	23.2 (590)	25.3 (643)
Minimum tank dimension above/below centre line (mm) 'Y'	8.5 (216)	11.5 (292)	14.5 (368)	16.0 (406)
Minimum Specific Gravity (S.G.)	0.72	0.8	0.82	0.85
Maximum differential (mm)	9.72 (247)	14.2 (360)	19.0 (483)	21.9 (555)

1. These dimensions in inches (mm) are approximate for cold water and will vary for liquids with a different specific gravity (SG.)

### Vertical F21 pump control and alarm float

Note: See Table 13 for dimensions S and T.

**Note**

Float assembly must be fitted from inside if for use in a vessel, or complete switch and float assembly may be mounted on a suitable bracket or manhole cover.

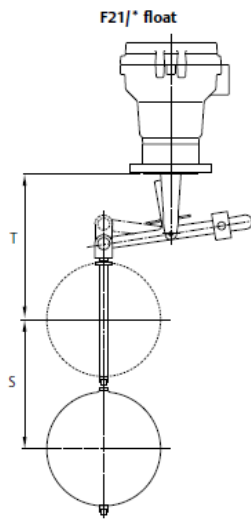

Float rod lengths available:

F21/1 5 ft. (1524 mm)

F21/2 10 ft. (3048 mm)

F21/3 15 ft. (4570 mm) maximum

Float rods may be cut to length on site and switches set to operate at required level in either pump control or alarm mode by following the supplied setting instructions.

**Table 13. Dimensions S and T for F21/+**

Pump differential 'S' in. (mm)	Alarm level in. (mm)	
	Minimum 'T'	Maximum 'S'
0.5 to 174.0 (13 to 4420) <sup>(1)</sup>	6.77 (172)	173.2 (4400) <sup>(1)</sup>

1. When the maximum rod length is specified.

**Figure 2. Pump Control and Alarm Applications**

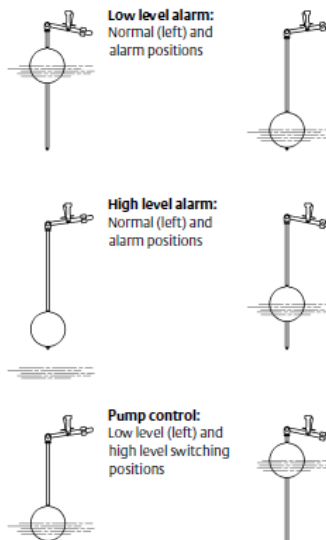

Magnetic Horizontal Level Switches  
Model: Hazardous areas

**Cranked arm floats F104**

Note: See Table 14 or Table 15 for dimensions in

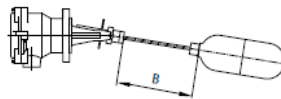
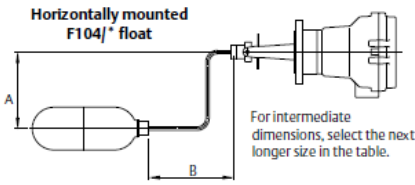

A plus B must not exceed 750 mm. A and B should each be equal to or greater than 75 mm, unless it is a straight arm where A is 0 mm (above).

To order, specify the F104 float with these details:

1. A and B (this page) or V and W (next page) dimensions.  
(For a straight arm float, state only the 'B' dimension).
2. Liquid in contact.
3. Specific Gravity (SG) of liquid.
4. Magnetic switch head type number (e.g. S01DB/F)
5. State land or marine application.

**Table 14. Dimensions A and B with Minimum SG for Horizontal - mounted Switches (Land Applications)**

		B																								
		75	100	125	150	175	200	225	250	275	300	325	350	375	400	425	450	475	500	525	550	575	600	625	650	675
A																										
0 & 75		.64	.64	.65	.66	.67	.67	.68	.69	.70	.71	.72	.73	.73	.74	.75	.76	.77	.78	.79	.80	.81	.81	.82	.83	.84
100		.64	.65	.66	.67	.68	.69	.70	.70	.71	.72	.73	.74	.75	.76	.77	.78	.79	.79	.80	.81	.82	.83	.84	.85	
125		.65	.66	.67	.68	.69	.70	.71	.72	.73	.74	.75	.75	.76	.77	.78	.79	.80	.81	.82	.83	.84	.85	.86		
150		.65	.67	.68	.69	.70	.71	.72	.73	.74	.75	.76	.77	.78	.79	.80	.81	.82	.83	.84	.85	.85	.86			
175		.66	.67	.69	.70	.71	.72	.73	.74	.75	.76	.77	.78	.79	.80	.81	.82	.83	.84	.85	.86	.87				
200		.66	.68	.70	.71	.72	.73	.75	.76	.77	.78	.79	.80	.81	.82	.83	.84	.85	.86	.87	.88					
225		.67	.69	.70	.72	.73	.75	.76	.77	.78	.79	.80	.81	.82	.84	.85	.86	.87	.88	.89						
250		.67	.69	.71	.73	.74	.76	.77	.78	.80	.81	.82	.83	.84	.85	.86	.87	.88	.89							
275		.68	.70	.72	.74	.76	.77	.78	.80	.81	.82	.83	.85	.86	.87	.88	.89	.90								
300		.68	.71	.73	.75	.77	.78	.80	.81	.82	.84	.85	.86	.87	.88	.89	.90									
325		.69	.71	.74	.76	.78	.80	.81	.83	.84	.85	.86	.88	.89	.90	.91										
350		.69	.72	.75	.77	.79	.81	.82	.84	.85	.87	.88	.89	.90	.92											
375		.70	.72	.76	.78	.80	.82	.84	.85	.87	.88	.90	.91	.92												
400		.71	.73	.76	.79	.81	.83	.85	.87	.88	.90	.91	.92													
425		.71	.74	.77	.80	.83	.85	.87	.88	.90	.91	.93														
450		.72	.74	.78	.81	.84	.86	.88	.90	.91	.93															
475		.72	.75	.79	.82	.85	.87	.89	.91	.93																
500		.73	.76	.80	.83	.86	.89	.91	.93																	
525		.74	.77	.81	.85	.88	.90	.92																		
550		.74	.77	.81	.86	.89	.92																			
575		.75	.78	.82	.87	.90																				
600		.76	.79	.83	.88																					
625		.76	.80	.84																						
650		.77	.80																							
675		.78																								

**Table 15. Dimensions A and B with Minimum SG for Horizontally - mounted switches (Marine Applications)**

		B																								
		75	100	125	150	175	200	225	250	275	300	325	350	375	400	425	450	475	500	525	550	575	600	625	650	675
A																										
0 & 75		.67	.67	.68	.68	.69	.69	.70	.71	.72	.73	.73	.74	.75	.76	.77	.78	.79	.79	.80	.81	.82	.83	.84	.85	.86
100		.68	.68	.69	.70	.70	.71	.72	.73	.74	.74	.75	.76	.77	.78	.79	.80	.81	.81	.82	.83	.84	.85	.86	.87	
125		.69	.70	.71	.71	.72	.73	.74	.75	.76	.76	.78	.77	.79	.80	.81	.82	.83	.84	.84	.85	.86	.87	.88		
150		.71	.71	.72	.73	.74	.75	.76	.77	.78	.78	.79	.80	.81	.82	.83	.84	.85	.86	.87	.88	.89	.89			
175			.73	.74	.75	.76	.77	.78	.79	.80	.81	.82	.83	.83	.84	.85	.86	.87	.88	.89	.90	.91				
200				.76	.77	.78	.79	.80	.81	.82	.83	.84	.85	.86	.87	.88	.89	.90	.90	.91	.92					
225				.79	.80	.81	.82	.83	.84	.85	.86	.86	.87	.88	.89	.90	.91	.92	.93	.94						
250					.83	.84	.85	.86	.87	.87	.88	.89	.90	.91	.92	.93	.94	.95	.95							
275						.88	.88	.89	.90	.91	.91	.92	.93	.94	.95	.96	.96	.97								
300						.93	.93	.93	.93	.94	.95	.95	.96	.97	.98	.99	.99									
325							.98	.98	.98	.98	.98	.99	1.0	1.0	1.01	1.02										
350								1.04	1.03	1.02	1.03	1.03	1.03	1.04	1.04											
375									1.09	1.08	1.07	1.07	1.07	1.08												
400										1.15	1.13	1.12	1.12													
425											1.20	1.18														

Magnetic Horizontal Level Switches

Model: Hazardous areas

Note: See Table 16 or Table 17 for dimensions in mm.

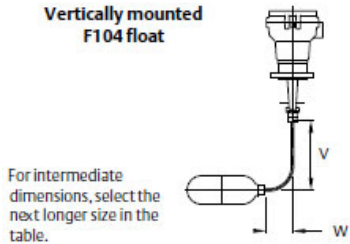

**Table 16. Dimensions V and W with Minimum SG for Vertically-mounted Switches (Land Applications)**

V	B																											
	75	100	125	150	175	200	225	250	275	300	325	350	375	400	425	450	475	500	525	550	575	600	625	650	675			
75	.67	.67	.66	.66	.66	.66	.67	.67	.68	.68	.68	.70	.70	.71	.72	.73	.73	.74	.75	.76	.77	.77	.78	.79	.80			
100	.67	.66	.66	.66	.66	.66	.67	.67	.68	.68	.69	.70	.70	.71	.72	.73	.73	.74	.75	.76	.77	.77	.78	.79				
125	.67	.66	.66	.66	.66	.66	.67	.67	.68	.68	.69	.70	.70	.71	.72	.73	.74	.74	.75	.76	.77	.78	.78					
150	.67	.66	.66	.66	.66	.66	.67	.67	.68	.68	.69	.70	.71	.71	.72	.73	.74	.74	.75	.76	.77	.78						
175	.67	.66	.66	.66	.66	.66	.67	.67	.68	.69	.69	.70	.71	.71	.72	.73	.74	.75	.75	.76	.77							
200	.67	.66	.66	.66	.66	.67	.67	.68	.68	.69	.69	.70	.71	.72	.72	.73	.74	.75	.75	.76								
225	.66	.66	.66	.66	.66	.67	.67	.68	.68	.69	.70	.70	.71	.72	.72	.73	.74	.75	.76									
250	.66	.66	.66	.66	.67	.67	.67	.68	.68	.69	.70	.70	.71	.72	.73	.73	.74	.75										
275	.67	.66	.66	.67	.67	.67	.68	.68	.69	.69	.70	.71	.71	.72	.73	.73	.74											
300	.67	.67	.66	.67	.67	.67	.68	.68	.69	.69	.70	.71	.71	.72	.73	.74												
325	.67	.67	.67	.67	.67	.67	.68	.68	.69	.70	.70	.71	.72	.72	.73													
350	.67	.67	.67	.67	.67	.68	.68	.69	.69	.70	.70	.71	.72	.72														
375	.68	.67	.67	.67	.67	.68	.68	.69	.69	.70	.71	.71	.72															
400	.68	.67	.67	.67	.68	.68	.68	.69	.70	.70	.71	.71																
425	.68	.68	.68	.68	.68	.68	.69	.69	.70	.70	.71																	
450	.68	.68	.68	.68	.68	.68	.69	.69	.70	.71																		
475	.69	.68	.68	.68	.69	.69	.69	.70	.70																			
500	.69	.69	.68	.68	.69	.69	.69	.70																				
525	.69	.69	.69	.69	.69	.69	.70																					
550	.70	.69	.69	.69	.69	.70																						
575	.70	.70	.69	.69	.70																							
600	.70	.70	.70	.70																								
625	.71	.70	.70																									
650	.71	.71																										
675	.72																											

**Table 17. Dimensions V and W with Minimum SG for Vertically-mounted Switches (Marine Applications)**

V	W																											
	75	100	125	150	175	200	225	250	275	300	325	350	375	400	425	450	475	500	525	550	575	600	625	650	675			
75	.75	.72	.70	.69	.68	.68	.68	.68	.68	.69	.70	.71	.71	.72	.73	.74	.74	.75	.76	.77	.78	.79	.79	.80	.81			
100	.76	.72	.70	.68	.67	.68	.68	.68	.69	.70	.70	.71	.72	.73	.73	.74	.75	.76	.77	.77	.78	.79	.80	.81				
125	.77	.72	.69	.67	.67	.68	.68	.69	.69	.70	.71	.72	.72	.73	.74	.75	.75	.76	.77	.78	.79	.80	.80					
150	.79	.72	.68	.67	.67	.68	.69	.69	.70	.71	.71	.72	.73	.74	.74	.75	.76	.77	.78	.78	.79	.80						
175		.71	.67	.67	.68	.68	.69	.70	.70	.71	.72	.73	.73	.74	.75	.76	.76	.77	.78	.79	.79							
200			.67	.68	.68	.69	.70	.70	.71	.72	.72	.73	.74	.75	.75	.76	.77	.78	.79	.79								
225				.68	.69	.70	.70	.71	.72	.72	.73	.74	.74	.75	.76	.77	.77	.78	.78									
250				.69	.70	.70	.71	.71	.72	.73	.74	.74	.75	.76	.77	.77	.78	.78										
275					.70	.71	.71	.72	.73	.73	.74	.75	.76	.76	.77	.78	.79											
300						.71	.73	.73	.73	.74	.75	.76	.76	.77	.78	.79												
325							.73	.73	.74	.75	.75	.76	.77	.78	.78													
350								.74	.75	.75	.76	.77	.78	.78														
375									.75	.76	.77	.77	.78															
400										.77	.77	.78																
425											.78																	

Magnetic Horizontal Level Switches  
Model: Aluminium-bronze & Stainless steel

## Approvals

### GLOBAL CERTIFICATION



#### **IECEX**

FLAMEPROOF

Certificate no. IECEX SIR 07.0081X

IEC 60079-0, IEC 60079-1, IEC 60079-26

For Zone 0/1

Ex db IIC T6...T1 Ga/Gb ( $-20^{\circ}\text{C} \leq T_{amb} \leq +60^{\circ}\text{C}$ ) or ( $-60^{\circ}\text{C} \leq T_{amb} \leq +60^{\circ}\text{C}$ )



#### **Functional Safety Certified**

Meets the requirements of IEC 61508-2:2010 for use in safety related systems.

Systematic capability: SC 2;

Random Capability: Type A element

SIL1, 2 capable with HFT 0 (1oo1); Route 2<sub>H</sub> and 2<sub>S</sub>

SIL Capability (Low Demand Mode) = SIL2 ; SIL Capability (High demand mode) = SIL1

Certificate No. CSA FSP 22001

**Note:** the associated full package of Safety Documentation must be listed on the order acknowledgement.

#### **MARINE**

**Lloyd's Register**

Certificate no. 88/00226

LR Test Specification No. 1

ENV1, ENV2



#### **NORTH AMERICA**

**Canadian Standards Association**

C22.2 NO 30

Class I, Div. 1, Groups C and D; CSA Enc 4

### EUROPEAN DIRECTIVES



#### **Low voltage Directive (LVD) 2014/35/EU.**

Compliant to LVD

#### **Pressure Equipment Directive (PED) 2014/68/EU:**

This product is outside the scope of the PED directive



II 1/2 G

#### **ATEX Directive 2014/34/EU**

FLAMEPROOF Certificate no. Sira 03ATEX1140X

Ex db IIC T6...T1 Ga/Gb ( $-20^{\circ}\text{C} \leq T_{amb} \leq +60^{\circ}\text{C}$ )

Ex db IIC T6...T1 Ga/Gb ( $-60^{\circ}\text{C} \leq T_{amb} \leq +60^{\circ}\text{C}$ )

### UK REGULATION



#### **Electrical Equipment (Safety) Regulations 2016 .**

Conform to UK SI 2016 No 1101 as amended

#### **Pressure Equipment (Safety) Regulations 2016 (Inc. Brexit amendments 2021):**

This product is outside the scope of the Regulation



II 1/2 G

#### **Equipment and Protective Systems Intended for use in Potentially Explosive Atmospheres Regulations 2016**

FLAMEPROOF Certificate no. CSAE 21UKEX1507X

Ex db IIC T6...T1 Ga/Gb ( $-20^{\circ}\text{C} \leq T_{amb} \leq +60^{\circ}\text{C}$ )

Ex db IIC T6...T1 Ga/Gb ( $-60^{\circ}\text{C} \leq T_{amb} \leq +60^{\circ}\text{C}$ )

## Ordering Accessories

**Table 18. Ordering Information for Accessories**

Accessories	Note: See page 9 for dimensions of Mobrey flanges
J800	Carbon steel welding pad for Mobrey 'G' flanged switches (see Figure 4 below)
71020/111	316 stainless steel welding pad for Mobrey 'G' flanged switches (see Figure 4 below)
J799	Carbon steel welding nozzle for Mobrey 'G' flanged switches (see Figure 4 below)

### Companion Flanges

**Figure 4. Companion Flanges Mobrey 'G' Flanged Switches**

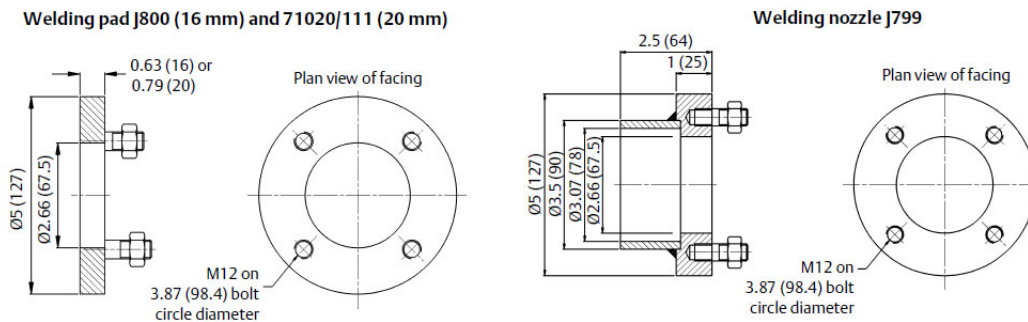

Note: Dimensions are in inches (mm).

#### Note

- Welding types supplied complete with studs and nuts.
- Other materials available upon request.

### Float chambers

Float chambers are used to facilitate the external mounting of the float switch onto a tank or pressure vessel, particularly where space inside the vessel is restricted or where the control must be isolated for routine maintenance whilst the plant is in operation. A wide range of fabricated chambers is available. Exotic materials are also available. Process connections may be specified as top-and-bottom or side-and-side, and can be flanged, screwed or butt welded in a choice of sizes to suit most plant installations. Please contact Delta Mobrey for further information.



In the interest of development and improvement Delta Mobrey Ltd, reserves the right to amend, without notice, details contained in this publication. No legal liability will be accepted by Delta Mobrey Ltd for any errors, omissions or amendments.

#### Delta Mobrey Limited

Riverside Business Park, Dogflud Way, Farnham, Surrey GU9 7SS, UK.  
 T+44 (0)1252 729140 F+44 (0)1252 729168 E sales@delta-mobrey.com W www.delta-mobrey.com



FM00720

Page 15 of 15