

Technical Datasheet



LEVEL GAUGE

Transparent type

Models: TLG

Key Features

- High reliability for use on steam and process applications.
- Complete shut off valves supplied.
- Handle position left or right.
- Easy and cost effective construction.
- A borosilicate crystal type.
- Suitable for saturated steam, hot water and aggressive fluids.

Series Overview

In this kind of level gauge, the fluid is contained between two glasses. Both crystals have a smooth surface. When the light passes through the back, the transparent crystal illuminates the chamber between two glasses, the level is clearly visible.

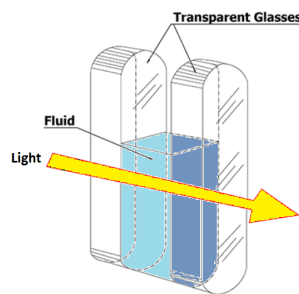

An illuminator can be added on the back, to facilitate the visibility of the level in a dim lit place or at night.

This kind of crystal makes the level gauge good for aggressive fluids or steam, a protective mica sheet can be installed between the fluid and the glass.

Other products

Other products in the series include:

- Conductive type, Hydrastep level control
- Glass type level gauge

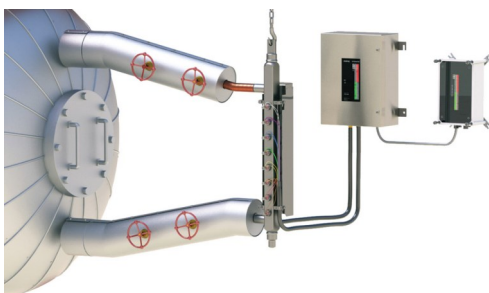

Product applications

Our Level Gauges are suitable for a wide range of applications in:

- Oil & Gas
- Chemical
- Petrochemical
- Refining
- Power

The choice of options ensures that the Transparent type level gauge series is suitable for use in:

- Boilers
- High pressure and temperature conditions
- Chemical aggressive media

How can we help you?

Delta Mobrey offers fast, efficient and knowledgeable support when and where you need it. Please visit our website at www.delta-mobrey.com to find your local support centre or call us on:

+44 (0) 1252 729140

Transparent Type Level Gauge
Models: TLG

How to order

Gauges can be configured by selecting codes representing the desired features from the tables that follow. The chart below, describes how the model code is built up. For assistance in configuring a switch that best suits your needs, please contact your local sales office.

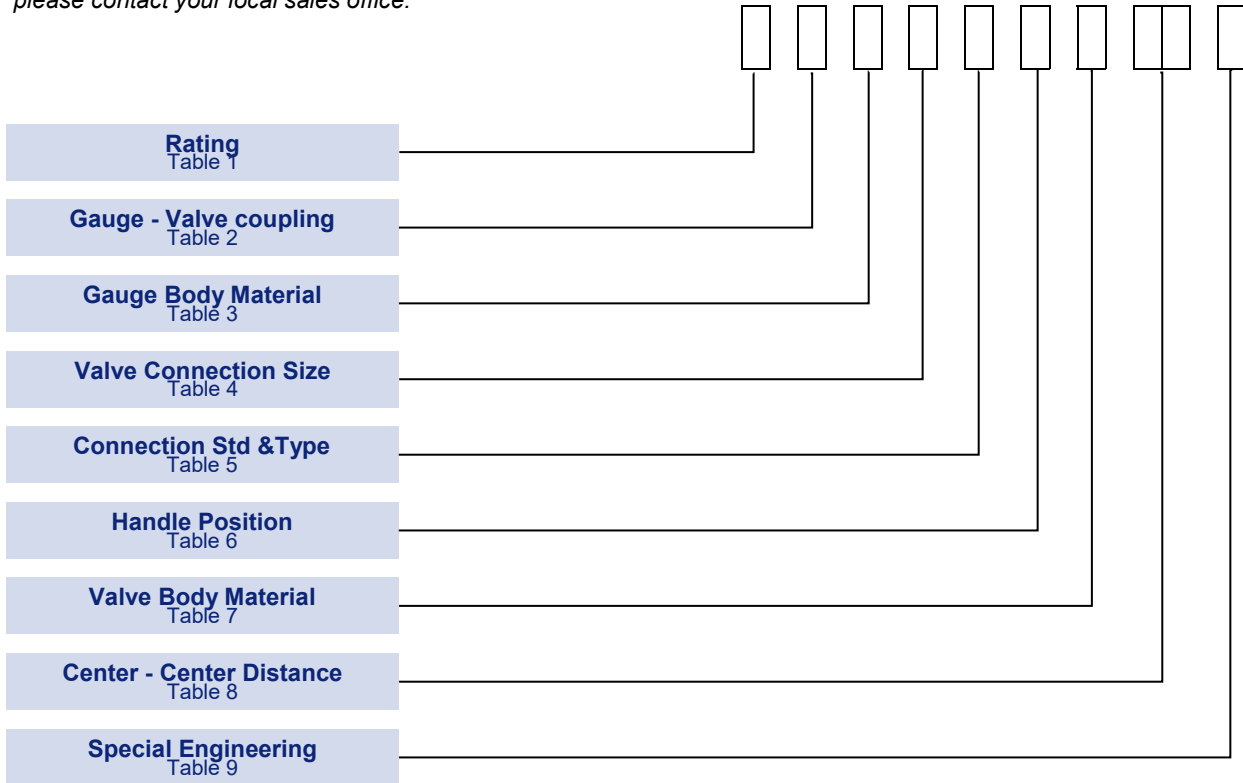

NOTE: The non-standard option code is shown by "X" in the part number. Should you require any clarification on this codes please contact your local sales office.

TO ENQUIRE ABOUT A QUOTATION FOR A LEVEL GAUGE, PLEASE SPECIFY:

- TYPE OF FLUID
- OPERATING CONDITION (PRESSURE AND TEMPERATURE)
- REQUIRED FLANGE FACE FINISHING (RF/FF/RTJ)
- MATERIAL OF CONSTRUCTION

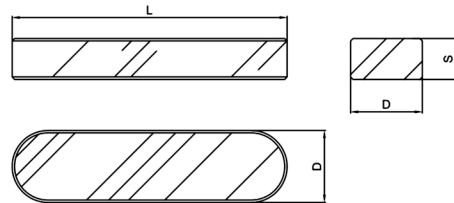

Transparent Type Level Gauge
Models: TLG

Technical Specification

Crystal
 Resistance to pressure : 200 bar
 Resistance to temperature : 300 °C
 Glass dimension: 30mm
 Reference Standards: DIN 7081 ; TGL 7210 ; BS 3463
 Expansion coefficient: acc. to DIN 52328
 Chilling strength: acc. to DIN ISO 718
 Hydrolytic resistance: acc. to DIN ISO 719
 Hydrolytic acid resistance: acc. to ISO 1776
 Alkali resistance: acc. to DIN ISO 695

Body Material of Gauge:
 See table on drawing page:
Dimension of the gauge:
 See drawing page
Body Material of upper/lower cock

dim.	PN40			PN64		
	L	D	S	L	D	S
11	115	30	17	115	34	17
12	140	30	17	140	34	17
13	165	30	17	165	34	17
14	190	30	17	190	34	17
15	220	30	17	220	34	17
16	250	30	17	250	34	17
17	280	30	17	280	34	17
18	320	30	17	320	34	17
19	340	30	17	340	34	17

Body Rating

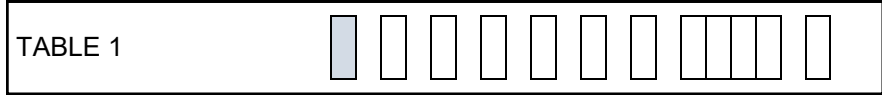

Description	Code
Transparent type Rating PN40	K
Transparent type Rating PN64	L

Gauge-Valve Coupling

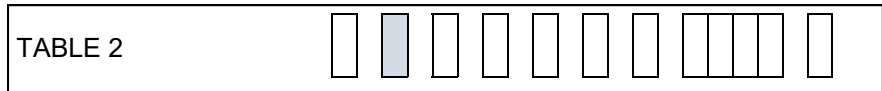

NOTE:
Consider the construction
See the table on drawings.

Description	Code
Type of connection between valves and gauge With end tubes and stuffing boxes .	B
Type of connection between valves and gauge With screwed nipples	A

Gauge Body Material

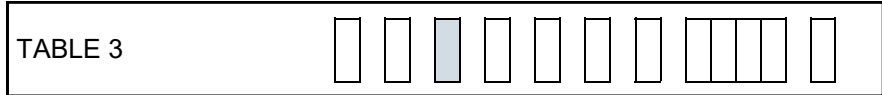

NOTE:
Consider the construction
See the table on drawings.

Description	Code
Carbon steel Body material in Carbon Steel.	H
Stainless Steel Body material in Stainless Steel.	B
Non standard Material	X

Valve Connection Size

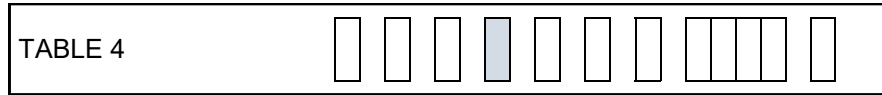

NOTE:
Construction and dimensions of the connection ANSI or DIN is defined by the rating of the valve..
See table 5.

Description	Code
½" to ANSI B 16.5	D
¾ " to ANSI B 16.5 or DN20 to BS4504	E
1" to ANSI B 16.5 or DN25 to BS4504	F
1 ½ "to ANSI B 16.5 or DN40 to BS4504	H
2" to ANSI B 16.5 or DN50 to BS4504	K

Connection Std &Type

NOTE :

Standard flange finishing is **RF** up to 600 lbs and **RTJ** for 900 & 1500 lbs. Different mix or FF finishing are available but on request as SPECIAL ENGINEERING

TABLE 5

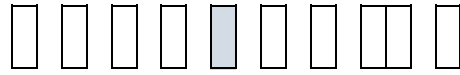

Description	Code
150 lbs.	A
300 lbs.	B
PN6	G
PN40	K
PN64	L
NPT MALE	N
NPT FEMALE	O
BSP MALE	P
BSP FEMALE	Q
SOCKET WELD	R
NON STANDARD	X

Handle Position

NOTE:

The handle of the valves can be settled to operate on the left or on the right.

TABLE 6

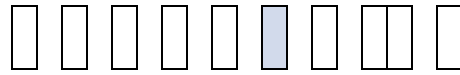

	Code
Level cock Handle Position Right handle position.	1
Level cock Handle Position	2

Valve Body Material

NOTE:

See drawing for the breakdown material of the cock valve.

TABLE 7

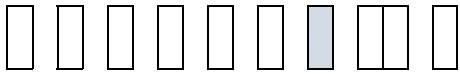

Description	Code
Carbon Steel	H
Stainless Steel	B
Non standard	X

Center - Center Distance

NOTE:

Refer to the drawings for all dimensions and visible length

TABLE 8

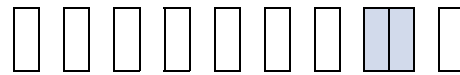

Description	Code
Centre - Centre Distance code Ax/Ay as shown in drawings	XX

Special Engineering

NOTE:

Last digits of model code only used when special engineering is required. Select the type of illuminator required 1,2 or 3 according to the power supply available on site.

TABLE 9

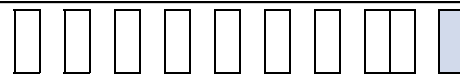

Description	Code
Illuminator 1 or 2 or 3 (see drawing, not manufactured by DELTA)	X
Please consult our sales engineering for special requirements	TBA

Dimensions

RATING PN40 = code K

All dimensions mm

Ax= center-center distance with end tubes and stuffing boxes.
Ay= center-center distance with threaded nipples

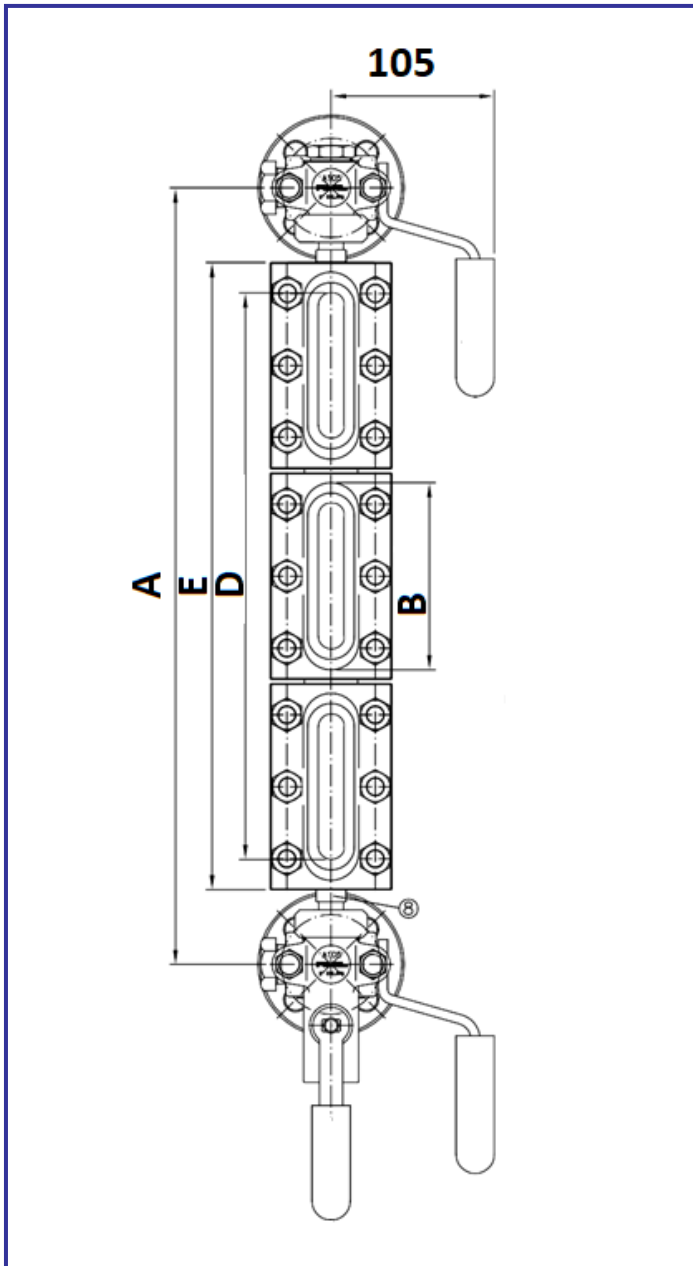

Dim. code	A _B min.	A _A min.	E	D +2 / 0	B
11	235	196	128	115	115
12	260	221	153	116	140
13	285	246	178	141	165
14	310	271	203	166	190
15	340	301	233	196	220
16	370	331	263	226	250
17	400	361	293	256	280
18	440	401	333	296	320
19	460	421	353	313	340
24	515	474	406	367	190
25	575	534	466	427	220
26	635	594	526	489	250
27	695	654	586	549	280
28	775	734	666	628	320
29	815	774	706	668	340
36	900	857	789	751	250
37	990	947	879	841	280
38	1110	1067	999	961	320
39	1170	1127	1059	1021	340
47	1285	1240	1172	1134	280
48	1445	1400	1332	1294	320
49	1525	1480	1412	1374	340
57	1580	1533	1465	1427	280
58	1780	1733	1665	1627	320
59	1880	1833	1765	1727	340
68	2115	2066	1998	1960	320
69	2235	2186	2118	2080	340
79	2590	2539	2471	2433	340

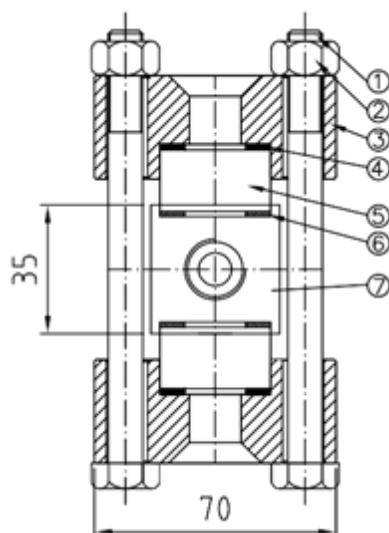

		A	B
1	Bolts	B7	B7
2	Nuts	2H	2H
3	Cover	Carbon Steel	Carbon steel
4	Upper gasket	Asbestos free	Gasbestos free
5	Glass	Borosilicate	Borosilicate
6	Lower gasket	Graphite	Graphite
7	Body	Carbon Steel	Stainless Steel
8	Nipples Up/Low	Stainless Steel	Stainless Steel

Transparent Type Level Gauge
Models: TLG

Dimensions

RATING PN64 = code L

All dimensions mm Ax= center-center distance with end tubes and stuffing boxes. Ay= center-center distance with threaded nipples

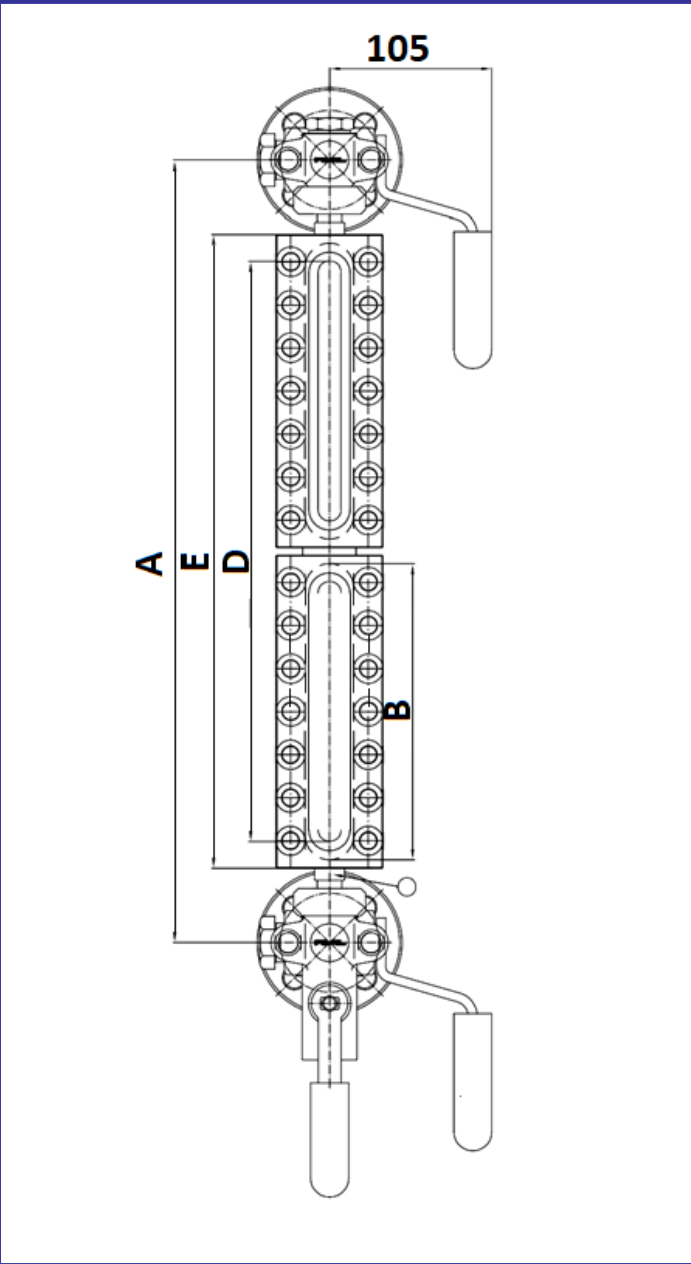

Dim. code	A _B min.	A _A min.	E	D +2 / 0	B
11	235	196	128	91	115
12	260	221	153	116	140
13	285	246	178	141	165
14	310	271	203	166	190
15	340	301	233	196	220
16	370	331	263	226	250
17	400	361	293	256	280
18	440	401	333	296	320
19	460	421	353	313	340
24	515	474	406	367	190
25	575	534	466	427	220
26	635	594	526	489	250
27	695	654	586	549	280
28	775	734	666	628	320
29	815	774	706	668	340
36	900	857	789	751	250
37	990	947	879	841	280
38	1110	1067	999	961	320
39	1170	1127	1059	1021	340
47	1285	1240	1172	1134	280
48	1445	1400	1332	1294	320
49	1525	1480	1412	1374	340
57	1580	1533	1465	1427	280
58	1780	1733	1665	1627	320
59	1880	1833	1765	1727	340
68	2115	2066	1998	1960	320
69	2235	2186	2118	2080	340
79	2590	2539	2471	2433	340

Transparent Type Level Gauge
Models: TLG

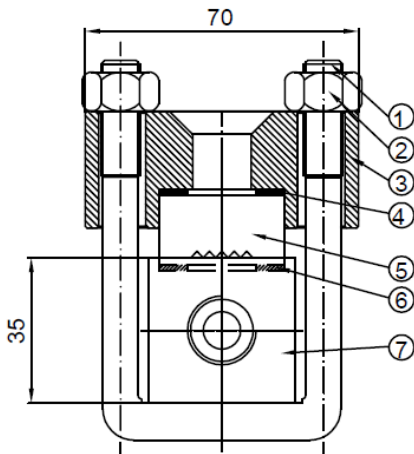

		A	B
1	Bolts	ASTM A193 B7	ASTM A193 B7
2	Nut	ASTM A194 2H	ASTM A194 2H
3	Cover	Carbon Steel	Carbon Steel
4	Upper gasket	Asbestos free	Asbestos free
5	Reflex Glass	Borosilicate	Borosilicate
6	Lower gasket	Graphite	Graphite
7	Level Body	Carbon Steel	Stainless Steel
8	Nipples	Stainless Steel	Stainless Steel

Dimensions

All dimensions mm (inches)

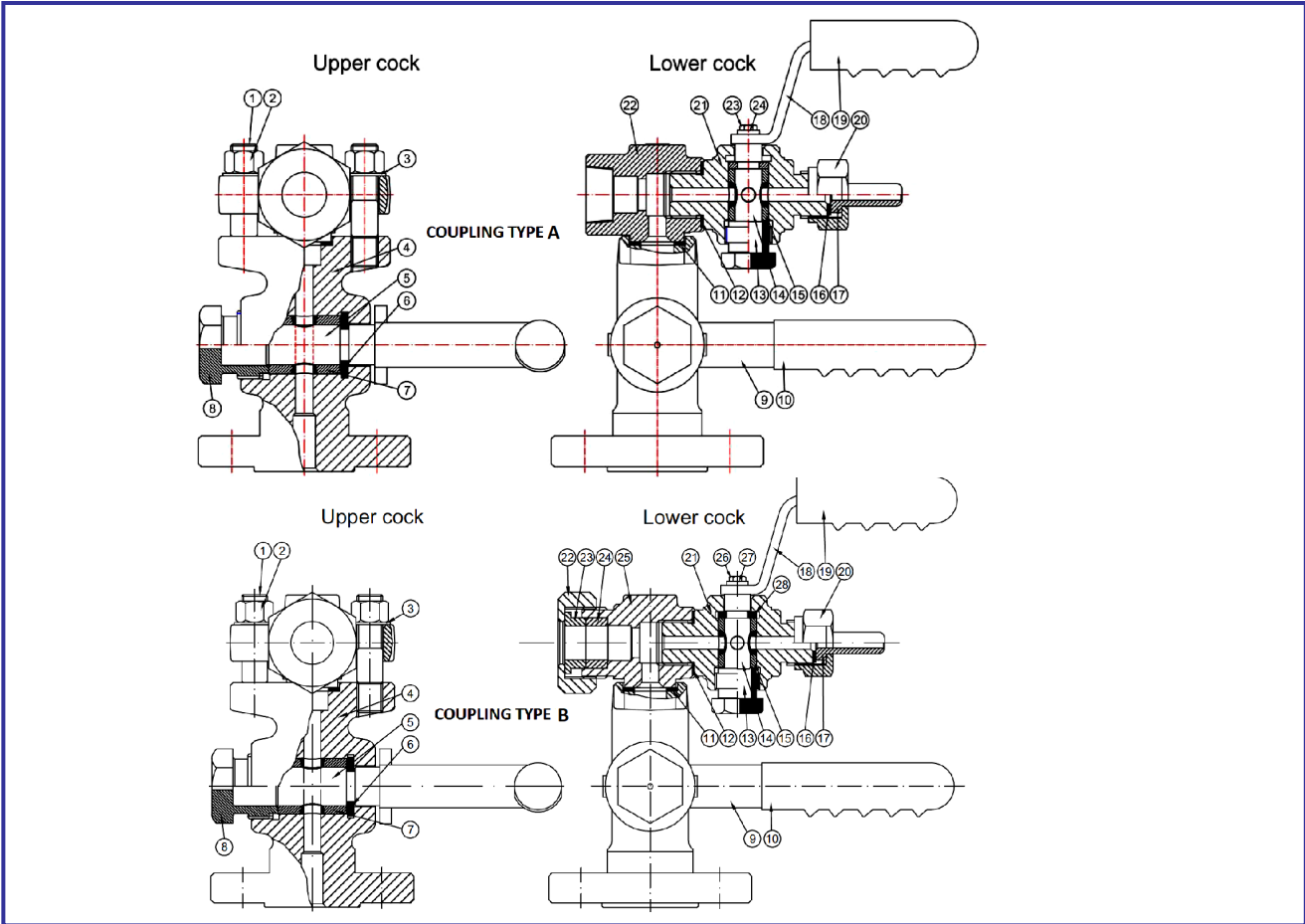

	COUPLING TYPE B	A	B
1	Bolts	ASTM A193 B7	ASTM A193 B8
2	Nut	ASTM A194 2H	DIN938 Gr.8
3	Washer	UNI 6592	F316L
4	Body	ASTM A105N	F316L
5	Plug F18	A316	A316
6	Ring F18	A316	A316
7	Packing Sleeves F18	Graphite	Grafite / Graphite
8	Stuffing box F18	Carbon Steel	ACC. INOX / S.steel
9	Big cock handle	Carbon Steel	Acc/C / C.steel
10	Big Cover Handle	Nylon 66	Nylon 66
11	Jooint Ring	Asbestos Free	Asbestos Free
12	Ring Thickness	A316	A316
13	Stuffing box F12	Carbon Steel	Stainless Steel
14	Plug F12	A316	A316
15	Packing Sleeves F12	Graphite	Graphite
16	Gasket	Asbestos Free	Asbestos Free
17	Connection pype	Carbon Steel	S.Steel
18	Little cock handle	Carbon Steel	Carbon Steel
19	Little cover handle	Nylon 66	Nylon 66
20	Draincock cover	Carbon Steel	ACC. INOX / S.steel
21	Drain cock	ASTM A105N	F316
22	Stuffing Box body	ASTM A105N	F316
23	Cap Screw	UNI 5739	UNI 5739
24	Washer	UNI 6592	UNI 6592

	COUPLING TYPE A	A	B
1	Bolts	ASTM A193 B7	ASTM A193 B8
2	Nut	ASTM A194 2H	DIN938 Gr.8
3	Washer	UNI 6592	F316L
4	Body	ASTM A105N	F316L
5	Plug F18	A316	A316
6	Ring F18	A316	A316
7	Packing Sleeves F18	Graphite	Grafite / Graphite
8	Stuffing box F18	Carbon Steel	ACC. INOX / S.steel
9	Big cock handle	ASTM A 105	Acc/C / C.steel
10	Big Cover Handle	Nylon 66	Nylon 66
11	Spirometallic	F316 / Graphite	F316 / Graphite
12	Ring Thickness	A316	A316
13	Stuffing box F12	Carbon Steel	Stainless Steel
14	Plug F12	A316	A316
15	Packing Sleeves F12	Graphite	Graphite
16	Gasket	Graphite	Graphite
17	Connection Type	Carbon Steel	S.Steel
18	Little cock handle	Carbon Steel	S.Steel
19	Little cover handle	Nylon 66	Nylon 66
20	Draincock cover	Carbon Steel	ACC. INOX / S.steel
21	Drain cock	ASTM A105N	F316
22	Connections cover	Carbon Steel	S.Steel
23	Stuffing box ring	Carbon Steel	S.Steel
24	Packing Sleeves F18	Graphite	Graphite
25	Stuffing bix body	ASTM A105N	F316
26	Cap screw	UNI 5739	UNI 5739
27	Washer	UNI 6592	UNI 6592
28	Ring F12	A316	A316

Transparent Type Level Gauge
Models: TLG

Dimensions

Special request : Illuminator 1 or 2 or 3

All dimensions mm (inches)

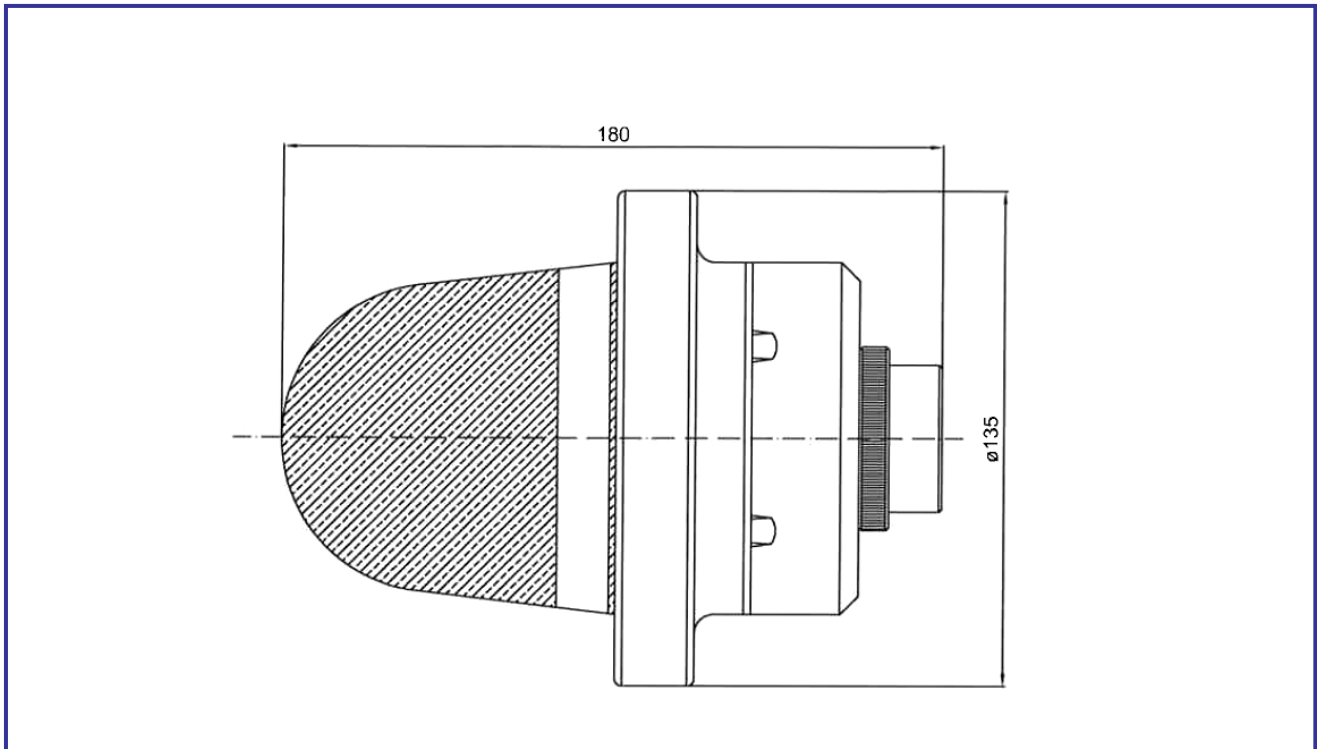

TYPE OF ILLUMINATOR	1	2	3
Voltage	12/24 Vdc	125 Vac	230Vac
Current rating	90-130 mA	15 mA	20 mA
Frequency		50/60 Hz	50/60 Hz
Power consumption	2 W	1.6 W	4.5 W
Lamp power	6 J	6 J	6 J
Type of Service	Continuous	Continuous	Continuous
Cable Entry	3/4" GK	3/4" GK	3/4" GK
ATEX certification	INERIS 01ATEX0068X	INERIS 01ATEX0068X	INERIS 01ATEX0068X
Body & Cover material	Aluminum	Aluminum	Aluminum
Transparent—Glass	Glass	Glass	Glass

In the interest of development and improvement Delta Mobrey Ltd, reserves the right to amend, without notice, details contained in this publication. No legal liability will be accepted by Delta Mobrey Ltd for any errors, omissions or amendments.

Delta Mobrey Limited

Hudson House, Albany Park Camberley Surrey, GU16 7PL, UK.

T+44 (0)1252 729140 F+44 (0)1252 729168 E sales@delta-mobrey.com W www.delta-mobrey.com



FM00720