

# Installation, Operation & Maintenance Instructions



## LEVEL GAUGES

Models TLG / GLG / RLG / WLG



### SAFETY INSTRUCTIONS

#### Information

- Points out useful tips, recommendations and information for efficient and trouble-free operation.



#### CAUTION!

- Indicates a potentially dangerous situation that can result in light injuries or damage to equipment or the environment, if not avoided.



#### WARNING!

- Indicates a potentially dangerous situation that can result in serious injury or death, if not avoided.



#### WARNING!

- Identifies hazards caused by electric power. Should the safety instructions not be observed, there is a risk of serious or fatal injury.



#### WARNING!

- Indicates a potentially dangerous situation that can result in burns, caused by hot surfaces or liquids, if not avoided.



#### WARNING!

- Indicates a potentially dangerous situation in the hazardous area that can result in serious injury or death, if not avoided.



#### Ex application

- Special instructions for Ex applications.

### General

The unit is manufactured, checked and supplied in accordance with our published specification. When installed and used in normal or prescribed applications within the parameters set for mechanical performance, it will not cause danger or hazard to life or limb.



THE USERS ATTENTION IS DRAWN TO THE FACT THAT, WHEN THE UNIT IS 'LIVE' WITH RESPECT TO ELECTRICAL OR PRESSURE SUPPLIES, A HAZARD MAY EXIST IF THE UNIT IS OPENED OR DISMANTLED.



UNITS MUST BE SELECTED AND INSTALLED BY SUITABLY TRAINED AND QUALIFIED PERSONNEL IN ACCORDANCE WITH APPROPRIATE CODES OF PRACTICE SO THAT THE POSSIBILITY OF FAILURE RESULTING IN INJURY OR DAMAGE CAUSED BY MISUSE OR MISAPPLICATION IS AVOIDED.

### Responsibility

Purchasers should ensure the product is suitable for use at the application and aggressive environments site. Read carefully the "Inadequate use" section below.

### Ambient Temperature

The surface temperature of the instrument is influenced by the process temperature, conditions, installation and environment. Special attention must be taken to exceed the limits specified on table below (i.e. special materials).

### Process temperature

The following standard reference table is applicable: Special construction for different and critical conditions, according to our engineers, will be specified.

TLG		
RLG		
GLW		
WLG		



### Inadequate use

Users must take care of the following during installation:

ASSEMBLANCE AND INSTALLATION OF THE NON-CORRECT EQUIPMENT (lacking total or partial non-observance of the instructions).

OBSERVANCE OF THE PRESCRIPTIONS OF USE POINTED OUT BY THE BUILDER MISSED.

NEGLIGENCE IN RESPECT OF THE SAFETY NORMS.

NO PURIFICATION OF THE WATER/PROCESS.

INTERVENT ON THE PRODUCT PREVENTIVELY NOT AUTHORISED BY THE MANUFACTURER.

USE OF NON ORIGINAL SPARE PARTS.

### Installation

Install the instrument in a safe condition, with boiler/tank at ambient temperature and taking care not to damage the instrument.



The installation, must be done by qualified personnel.

Once the instrument has been installed and when the defined process condition (both pressure and temperature) is reached for the first time, if leaks occur from the sealing gasket / glass, tighten the nut.

Tightening must be done in an alternative way, using a torque wrench (tightening torques as per our table below).

If the leak occurs on the valves please operate on the relative plug/box (see details 8 and 13 of the drawing of the valves with coupling type B or A), these operations must be repeated, bringing small corrections until you get a definitive sealing.

## Dismantlement

-  Before any maintenance, shut off, void the boiler then wait until the instrument has reached a safe temperature limit.
-  The dismantlement, must be done by qualified personnel.

To remove the level gauge safely from the plant, follow the steps below:

- Close the valves of interception
- Detach the group of the level gauges
- Unscrew bolts and nuts to an appropriate dismantlement of all the components.
- Clean the sealing area of the gauge eliminating every residual or dirt.
- On the valves intervene on the body (see details 7 and 15 of ours fig. of gauges) unscrewing the stuffing box, and extract from the chamber the relative male/cock.

## Maintenance

The service on the instrument, must be done by qualified personnel.

-  The substitution of crystals and gaskets must be done with guaranteed products and must be original parts from the manufacturer. The activity, must be done in an appropriate environment once set, proceed with an accurate reconstitution. Care must be taken on limits of tightening of the bolts for suitable seal (as our table).

Particular care, must be taken when assembling the valves. Apply on the shutter the sealing ring (see details 6 and 28 of ours valve with coupling B / details 6 and 25 of valves with coupling A).

Then insert the packing sleeves into the seat until it stops and introduce everything in the clean chamber of the cock body. Add the stuffing box to the handle and shut both in adequate and harmonic way to get a full-bodied movement of the lever.

## Disposal

Any possible residue from process fluids will have to be disposed of in accordance with local environmental law.

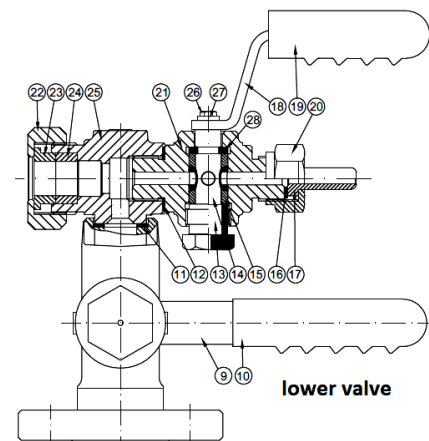
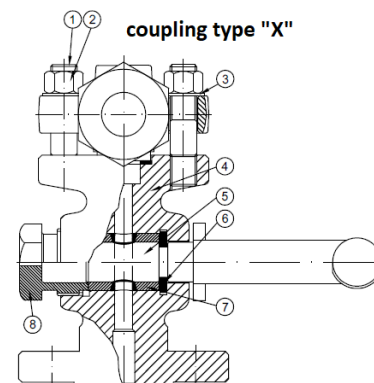
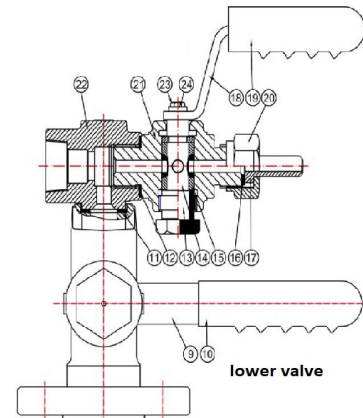
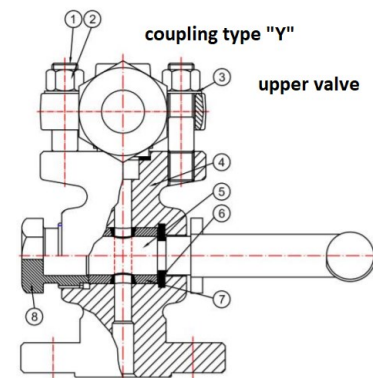

**PARTS**

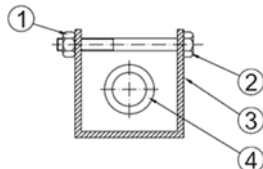
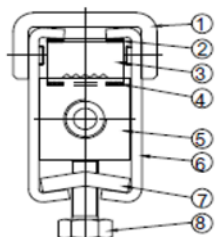
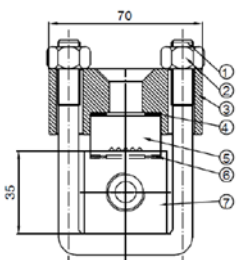
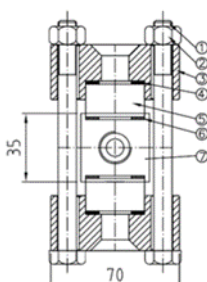
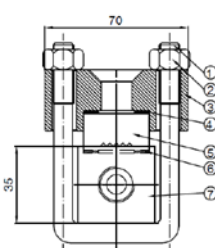
<p><b>GLG</b></p>	 <table border="1" data-bbox="598 369 774 504"> <tr><td>1</td><td>Nut</td></tr> <tr><td>2</td><td>Bolt</td></tr> <tr><td>3</td><td>Protection tube</td></tr> <tr><td>4</td><td>Glass Tube</td></tr> <tr><td>5</td><td>Gasket Glass/Valve</td></tr> </table>	1	Nut	2	Bolt	3	Protection tube	4	Glass Tube	5	Gasket Glass/Valve								
1	Nut																		
2	Bolt																		
3	Protection tube																		
4	Glass Tube																		
5	Gasket Glass/Valve																		
<p><b>RLG PN40</b></p>	 <table border="1" data-bbox="598 604 774 817"> <tr><td>1</td><td>Safety clamps</td></tr> <tr><td>2</td><td>Upper gasket</td></tr> <tr><td>3</td><td>Reflex Glass</td></tr> <tr><td>4</td><td>Lower gasket</td></tr> <tr><td>5</td><td>Level body</td></tr> <tr><td>6</td><td>Cover plate</td></tr> <tr><td>7</td><td>Tightening bolts</td></tr> <tr><td>8</td><td>Bolts</td></tr> <tr><td>9</td><td>Nipples Up/Low</td></tr> </table>	1	Safety clamps	2	Upper gasket	3	Reflex Glass	4	Lower gasket	5	Level body	6	Cover plate	7	Tightening bolts	8	Bolts	9	Nipples Up/Low
1	Safety clamps																		
2	Upper gasket																		
3	Reflex Glass																		
4	Lower gasket																		
5	Level body																		
6	Cover plate																		
7	Tightening bolts																		
8	Bolts																		
9	Nipples Up/Low																		
<p><b>RLG PN64 &amp; 100</b></p>	 <table border="1" data-bbox="598 907 774 1097"> <tr><td>1</td><td>Bolts</td></tr> <tr><td>2</td><td>Nut</td></tr> <tr><td>3</td><td>Cover</td></tr> <tr><td>4</td><td>Upper gasket</td></tr> <tr><td>5</td><td>Reflex Glass</td></tr> <tr><td>6</td><td>Lower gasket</td></tr> <tr><td>7</td><td>Level Body</td></tr> <tr><td>8</td><td>Nipples</td></tr> </table>	1	Bolts	2	Nut	3	Cover	4	Upper gasket	5	Reflex Glass	6	Lower gasket	7	Level Body	8	Nipples		
1	Bolts																		
2	Nut																		
3	Cover																		
4	Upper gasket																		
5	Reflex Glass																		
6	Lower gasket																		
7	Level Body																		
8	Nipples																		
<p><b>TLG PN40</b></p>	 <table border="1" data-bbox="614 1254 774 1433"> <tr><td>1</td><td>Bolts</td></tr> <tr><td>2</td><td>Nuts</td></tr> <tr><td>3</td><td>Cover</td></tr> <tr><td>4</td><td>Upper gasket</td></tr> <tr><td>5</td><td>Glass</td></tr> <tr><td>6</td><td>Lower gasket</td></tr> <tr><td>7</td><td>Body</td></tr> <tr><td>8</td><td>Nipples Up/Low</td></tr> </table>	1	Bolts	2	Nuts	3	Cover	4	Upper gasket	5	Glass	6	Lower gasket	7	Body	8	Nipples Up/Low		
1	Bolts																		
2	Nuts																		
3	Cover																		
4	Upper gasket																		
5	Glass																		
6	Lower gasket																		
7	Body																		
8	Nipples Up/Low																		
<p><b>TLG PN64</b></p>	 <table border="1" data-bbox="614 1624 774 1803"> <tr><td>1</td><td>Bolts</td></tr> <tr><td>2</td><td>Nut</td></tr> <tr><td>3</td><td>Cover</td></tr> <tr><td>4</td><td>Upper gasket</td></tr> <tr><td>5</td><td>Reflex Glass</td></tr> <tr><td>6</td><td>Lower gasket</td></tr> <tr><td>7</td><td>Level Body</td></tr> <tr><td>8</td><td>Nipples</td></tr> </table>	1	Bolts	2	Nut	3	Cover	4	Upper gasket	5	Reflex Glass	6	Lower gasket	7	Level Body	8	Nipples		
1	Bolts																		
2	Nut																		
3	Cover																		
4	Upper gasket																		
5	Reflex Glass																		
6	Lower gasket																		
7	Level Body																		
8	Nipples																		

TORQUE BOLT FOR LEVEL GAUGES			
Type	PN	Dim.	force
<b>RLG</b>	PN40	13 to 16	37 Nm
	PN40	17 to 19	36 Nm
	PN64	11 to 19	40 Nm
<b>WLG</b>	PN100	11 to 19	47 Nm
<b>TLG</b>	PN64	11 to 19	47 Nm
	PN64	11 to 19	47 Nm

**Delta Mobrey Ltd**  
Hudson House, Albany Park Camberley Surrey, GU16 7PL, UK.  
**T** +44 (0)1252 729140 **F** +44 (0) 1252 729168 **W** [www.delta-mobrey.com](http://www.delta-mobrey.com)



FM00720