

Mobrey MLT100

Displacer Level Transmitter



- Level, contents or interface measurement transmitter
- Direct or external chamber mounting
- Two-wire 24 Vdc loop-powered
- 4–20 mA HART[®] output
- ATEX Intrinsically safe and explosion-proof certified versions

Overview of the Mobrey MLT100



Mobrey MLT100 Transmitter With Optional Display Fitted



Mobrey MLT100 Transmitter in a Side-and-bottom Chamber

The Mobrey MLT100 Level Transmitter is one of the most advanced displacer based devices on the market, coupling the time proven buoyancy principle with state of the art electronics in an instrument of high reliability and stability.

Special care has been taken in design to ensure a small mounting envelope is maintained, resulting in reduced weight and associated savings in mounting.

The displacer element is made to length for each order, and is suspended below the head on a stable spring arrangement which is designed to minimise friction effects and improve performance.

The transmitter can be mounted directly into a vessel or may be externally mounted in a chamber to allow isolation for planned maintenance or in-situ calibration checks.

Operation

The 4–20 mA output from the head is proportional to the level or contents in the vessel, or may be set to follow an interface. The transmitter supports the HART protocol, which is superimposed on the 4–20 mA signal.

Changes of liquid level in the vessel cause the displacer element, which is supported on a spring, to rise or fall. A core, located in the pressure tube of the head, is connected to the displacer and moves linearly up and down with the element. Around the outside of the pressure tube in the head is a Linear Variable Differential Transformer (LVDT), the output of which is proportional to the position of the core. The pressure tube is made of stainless steel and is welded to the union which connects the head to the process pressure and temperature.

The user can operate the transmitter without digital communications, or can take advantage of the many features of HART such as remote calibration, re-ranging, on-line diagnostics, and multidrop installations.

Features

- Two-wire 24 Vdc loop-powered
- 4–20 mA output
- Unique ‘Caliplug’ for local configuration and calibration
- HART communications
- EExd or EExia certification
- Simple local or remote calibration
- Non-interactive Zero and Span
- High temperature remote electronics option (available to special order)
- Optional display for local indication of measurement
- Range of wetside materials

Contents

Overview of the Mobrey MLT100	page 2	Dimensions	page 7
Mobrey MLT100 Transmitter Ordering	page 4	Product Certifications	page 8
Specifications	page 6		

Benefits

- Low maintenance
- Simple installation
- Local or remote calibration

Typical applications

- Knock-out pots
- Condensate drums
- Separators
- Flash vessels
- Storage vessels
- Receiver tanks

Operating wet-side temperatures are -60 to 320 °C at pressures between full vacuum and 200 bar. Remote electronics models available to special order for high temperature and nuclear applications.

Most liquids can be measured, with wetted materials chosen to suit. The liquid SG range is from 0.5 to 1.5, and interfaces with as low an SG difference of 0.1 are also practical.

The displacer length is dictated by the operating range requested, and the diameter and weight are factory calculated to ensure the correct operating movement of the core in the head. The longest standard operating range is 3000 mm.

Special features

Health-check LED

Each transmitter is fitted with a visible LED which flashes once every 3 seconds to show the instrument is healthy and working.

Field adjustments

The transmitter is set up by Delta Mobrey to operate in the conditions advised at the time of order, and the displacer element dimensions are chosen to suit.

Local Calibration (Without a Field Communicator)

Fine-tune adjustments on-site may be made with the instrument in an empty vessel at 20 °C, which ensures correct readings at operating conditions.

Several adjustments can be made using the unique “Mobrey Magnetic Scroller” (MMS) and the “Caliplug”.

The MMS is a calibration tool with a magnetic tip, and is used on this and other Delta Mobrey instruments to access and adjust certain operating parameters.

The MLT100 is fitted with a calibration plug (Caliplug) which contains docking ports for the MMS along with a heartbeat LED. The adjustments which may be made are setting the 4 mA and 20 mA points, and damping.

Remote calibration

(not necessary for standard 4–20 mA operation)

Ranging can be carried out remotely using a Field Communicator to establish digital communications and set the 4 and 20mA points electronically without the need for changing the liquid level. All the remaining operating, diagnostic, and Process Value (PV) data is also available using a Field Communicator.

Local indication display (optional)

The optional multi-function LCD indicator is housed in a cast aluminum Exd enclosure, and finished in a two-pack epoxy white paint. The 2-line LCD display can be programmed to show the output in %, engineering units, and other operating parameters by using a Field Communicator.

Mobrey MLT100 Transmitter Ordering

The following information must be supplied at time of order:

- Operating pressure, temperature, specific gravities (upper and lower), and viscosity
- Liquid and nature of vapour (condensing or non-condensing)
- Maximum or design pressures and temperatures
- Ambient temperature and local environmental conditions
- Operating range (taken as the process connection centres unless otherwise stated)
- Mounting arrangement and specific construction materials required.
(If a chamber is required, please specify all relevant dimensions. Non-standard configurations may be made to special order)
- Any options: Display, chamber connections or vent/drain, special paint, inspection and NDT requirements, or other

Table 1. Mobrey MLT100 ordering information

Model	Product Description
LT	Mobrey level transmitter
Flange Material	
C	Carbon steel
S	Stainless steel
N	No flange (1-in. NPT connection)
Flange Mounting	
60	3-in. ASME B16.5 Class 150 Raised Face (RF)
61	3-in. ASME B16.5 Class 300 Raised Face (RF)
62	3-in. ASME B16.5 Class 600 Raised Face (RF)
63	3-in. ASME B16.5 Class 900 Raised Face (RF)
64	3-in. ASME B16.5 Class 1500 Ring Type Joint (RTJ)
65	4-in. ASME B16.5 Class 150 Raised Face (RF)
66	4-in. ASME B16.5 Class 300 Raised Face (RF)
67	4-in. ASME B16.5 Class 600 Raised Face (RF)
68	4-in. ASME B16.5 Class 900 Raised Face (RF)
69	4-in. ASME B16.5 Class 1500 Ring Type Joint (RTJ)
71	DN80 PN16
72	DN80 PN25
73	DN80 PN40
76	DN100 PN16
77	DN100 PN25
78	DN100 PN40
00	No flange (1-in. NPT connection)
Enclosure	
TS	IP66 enclosure certified EExia for Intrinsic Safety (IS) use, Cast Iron, white epoxy painted.
TF	IP66 Flameproof enclosure certified EExd for hazardous area use, Cast Iron, white epoxy painted
TR	IP66 enclosure certified EExd with electronics in a remote IP66 aluminium enclosure. Note: Remote electronics must be in the non-hazardous area.
TX	IP66 enclosure certified EExia for Intrinsic Safety (IS) use, 316 stainless steel.
Pressure Tube Type – Select Type A or B using Figure 1 on page 6	
A	Standard (up to 224 °C condensing)
B	High temperature (224 °C to 277 °C condensing; 320 °C non-condensing, remote electronics to 320 °C condensing)
Display	
D	Display
N	No display

Table 1. Mobrey MLT100 ordering information

Spring	
*	The code for the spring will be selected by Delta Mobrey at time of ordering
Displacer	
*	The code for the displacer will be selected by Delta Mobrey at time of ordering
Chamber Type and Orientation	
A	No chamber
B	Side/bottom, no vent
C	Side/bottom, 1/2-in. NPT vent
D	Side/bottom, 3/4-in. NPT vent
F	Side/bottom, 3/4-in. flanged vent
G	Side/side, no vent, 1/2-in. NPT drain
H	Side/side, no vent, 3/4-in. NPT drain
J	Side/side, no vent, 1-in. NPT drain
K	Side/side, 1/2-in. NPT drain and vent
L	Side/side, 3/4-in NPT drain and vent
M	Side/side, 1-in. NPT drain and vent
N	Side/side, no vent, 3/4-in. drain
P	Side/side, 3/4-in. NPT vent, 3/4-in. flanged drain
Q	Side/side, 3/4-in. flanged drain and vent
Chamber Process Connections	
01	Screwed 1-in. NPT
00	No Chamber
11	1-in. ASME B16.5 Class 150 Raised Face (RF) flange
12	1-in. ASME B16.5 Class 300 Raised Face (RF) flange
13	1-in. ASME B16.5 Class 600 Raised Face (RF) flange
14	1-in. ASME B16.5 Class 900 Raised Face (RF) flange
18	1-in. ASME B16.5 Class 1500 Ring Type Joint (RTJ) flange
15	DN25 PN16
16	DN25 PN25
17	DN25 PN40
21	1 1/2-in. ASME B16.5 Class 150 Raised Face (RF) flange
22	1 1/2-in. ASME B16.5 Class 300 Raised Face (RF) flange
23	1 1/2-in. ASME B16.5 Class 600 Raised Face (RF) flange
24	1 1/2-in. ASME B16.5 Class 900 Raised Face (RF) flange
28	1 1/2-in. ASME B16.5 Class 1500 Ring Type Joint (RTJ) flange
25	DN40 PN16
26	DN40 PN25
27	DN40 PN40
31	2-in. ASME B16.5 Class 150 Raised Face (RF) flange
32	2-in. ASME B16.5 Class 300 Raised Face (RF) flange
33	2-in. ASME B16.5 Class 600 Raised Face (RF) flange
34	2-in. ASME B16.5 Class 900 Raised Face (RF) flange
38	2-in. ASME B16.5 Class 1500 Raised Face (RF) flange
35	DN50 PN16
36	DN50 PN25
37	DN50 PN40
Options (Factory Defined)	
00	None
**	The code for non-standard options will be allocated at time of ordering i.e. AQ for Seal welded union/flange and M20 conduit
Typical Model Number: LTC 61 TS A D * * B 11 00	

Specifications

Output

- 4–20 mA / HART digital

Range

- 11.8 to 118 in. / 300 to 3000 mm (to order)

Maximum operating pressure

- 2900 psi (200 bar)

Minimum operating pressure

- Full vacuum

Specific gravity range

- Standard: 0.5 to 1.5
- Interface: 0.1 difference

Maximum operating temperatures

- 530 °C (277 °C) condensing
- 608 °F (320 °C) non-condensing
- 608 °F (320 °C) condensing with remote electronics

Minimum operating temperature

- -76 °F (-60 °C)

Ambient temperature

- -40 to 176 °F / -40 to 80 °C (subject to process temperature)

Accuracy

- < ±1% of output span

Repeatability

- ±0.2% of output span

Linearity

- 0.2% of output span

Resolution

- 0.1% of output span

Hysteresis

- 0.3% of output span

Power supply

- 12 to 40 Vdc loop-powered

Power consumption

- 21 mA / 40 V: 840 mW maximum

Pressure Tube Types A and B

- See “Graphs for selecting a pressure tube type” on page 6

Materials of Construction

- The transmitter head is manufactured from cast iron with a paint finish of two-pack Epoxy white paint suitable for offshore/coastal use. It is weatherproof to IP66 / IP67 ratings.
- Wetted parts are made from stainless steel, including the element, trim, and pressure tube, except for the spring which is manufactured from a specialist corrosion resistant spring material, NIMONIC, chosen for its stability and repeatability under changing process conditions.

Optional Chamber

- The material used is either as specified on the order or selected by Delta Mobrey to suit the application. Only certified materials are used, and welding is qualified to ASME IX, BS EN 287, and EN ISO 15614-1. All pressure retaining parts are hydrostatically pressure tested to a minimum of 1.5 times working pressures. NDT including radiography and dye penetrant testing is available when specified at time of ordering. Inspection by customers or their appointed agents is welcome provided that this is requested at time of ordering.
- Option: Wetside materials in Alloy C276 (UNS N10276), Alloy 625 (UNS N06625), and others on request
- Option: compliance with NACE MR-01-75 for sour service duty

Figure 1. Graphs for selecting a pressure tube type

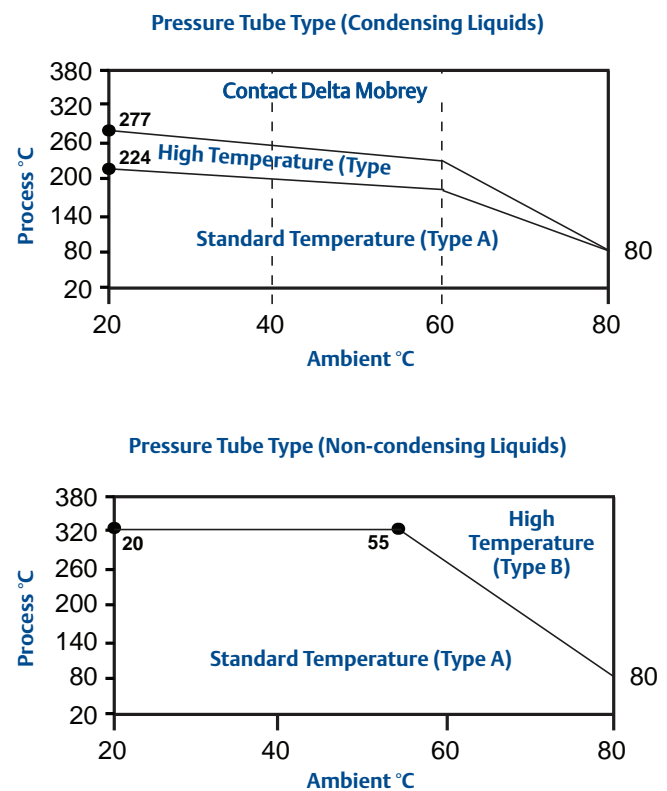

Dimensions

Figure 2. MLT100 with Optional Display

Note: Dimensions are in mm.

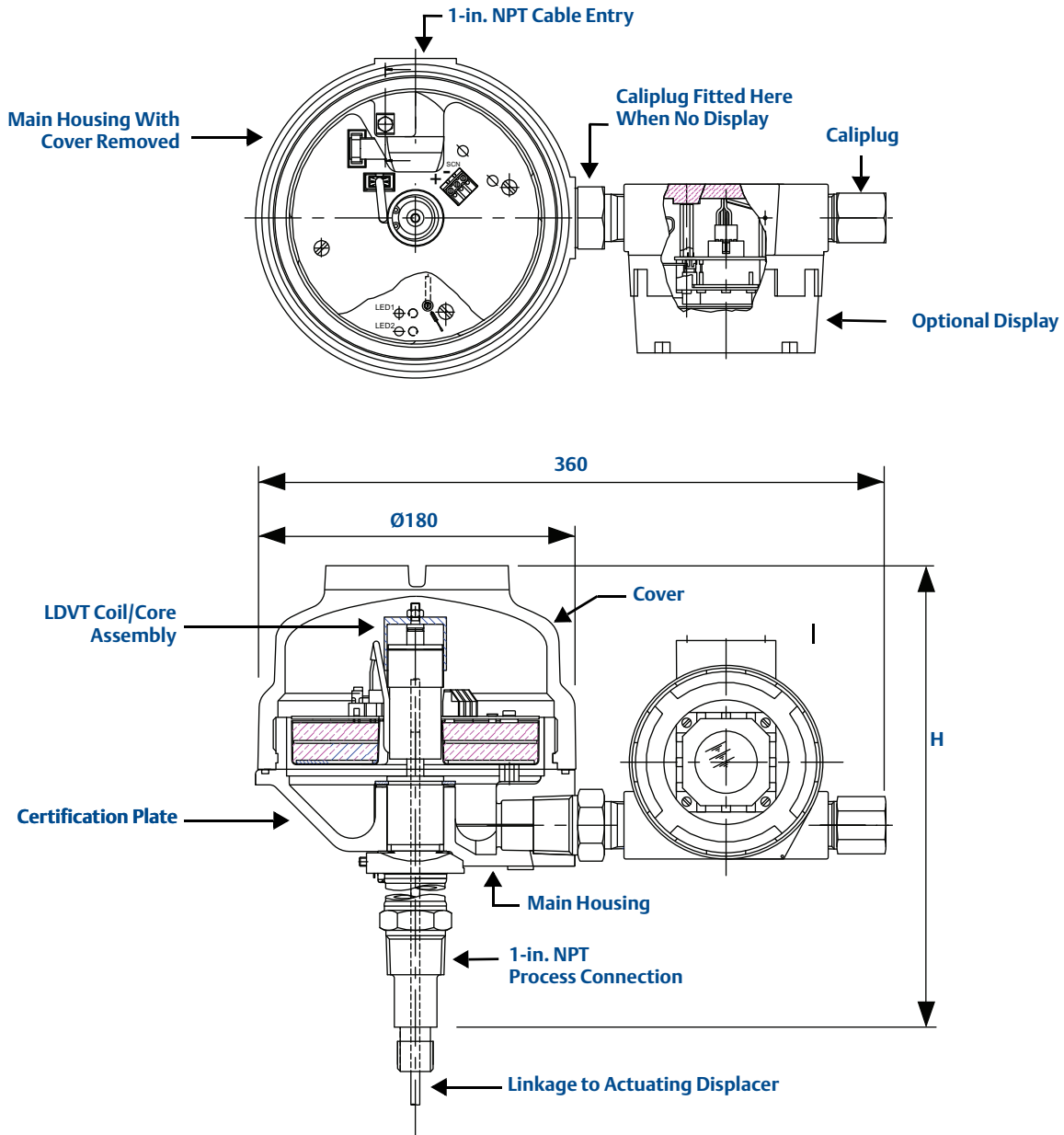

Table 2. Head height dimension H

Head Height	H
Pressure Tube A	200 mm
Pressure Tube B	422 mm
Note: allow an extra 90 mm for cover removal	

Product Certifications

Approved manufacturing location

Delta Mobrey Limited, Slough, United Kingdom

European directive information

The EC declaration of conformity certificate for all applicable European directives for this product can be found on the Mobrey brand pages at www.delta-mobrey.com. A hard copy may be obtained by contacting your local sales office.

ATEX Directive

- The MLT100 complies with the ATEX directive

Pressure Equipment Directive (PED)

- The MLT100 complies with the PED directive

Electro Magnetic Compatibility (EMC) Directive

- EN 61326-1:2013, EN 61326-2.3:2013

Hazardous locations certifications

ATEX intrinsically safe approval (enclosure code TS only)

Certificate number: Sira 03ATEX2153X

II 1 G

II 1 D (T90 °C)

EEx ia IIC T5 (T_a = -40 to 40 °C)

EEx ia IIC T4 (T_a = -40 to 80 °C)

Input parameters:

U_i = 28 Vdc, I_i = 93 mA, P_i = 0.66 W, C_i = 48 nF, L_i = 0.22 mH

Output parameters

(at the programming/calibration connector):

U_o = 18 Vdc, I_o = 93 mA, P_o = 0.44 W, C_o = 0.309 μF, L_o = 4.2 mH

ATEX intrinsically safe approval (enclosure code TX only)

Certificate number: Sira 04ATEX2206X

II 1 G

EEx ia IIC T5 (T_a = -40 to 40 °C)

EEx ia IIC T4 (T_a = -40 to 80 °C)

Input parameters:

U_i = 28 Vdc, I_i = 93 mA, P_i = 0.66 W, C_i = 48 nF, L_i = 0.22 mH

Output parameters

(at the programming/calibration connector):

U_o = 18 Vdc, I_o = 93 mA, P_o = 0.44 W, C_o = 0.309 μF, L_o = 4.2 mH

ATEX EEx ia special conditions for safe use

1. The enclosure may be manufactured from alloys containing light metals. In rare cases, ignition sources due to impact and friction sparks could occur. This shall be considered when the equipment is installed in locations that specifically require group II, category 1G equipment.

ATEX flameproof approval (enclosure codes TF and TR only)

Certificate number: Sira 03ATEX1190X

II 1/2 G

II 1/2 D (T85 °C)

EEx d IIC T6 (T_a = -40 to 75 °C)

ATEX EEx d special conditions for safe use:

1. The enclosure must not be opened when a flammable atmosphere is present, even when the equipment has been electrically isolated.
2. The partition wall may not be stainless steel (see [page 7](#)), therefore the MLT100 shall not be subjected to environmental stresses that might adversely affect the partition wall.
3. The float or mounting flange may be a non-metallic material. The user must ensure suitability for the application and not ignition capable due to electrostatic charging. Do not rub with a dry cloth.

Standard Terms and Conditions of Sale can be found at www.delta-mobrey.com/terms-conditions/

Delta Mobrey Limited
Hudson House, Albany Park Camberley
Surrey, GU16 7PL, UK.
Tel +44 (0)1252 729 140
Fax +44 (0)1252 729 168
www.delta-mobrey.com