

PLS Series

Rotary Paddle Level Switch – SafePoint model



Contents

1	Introduction	4
1.1	Unpacking	4
1.2	Model identification	4
2	Pre-installation considerations	5
2.1	Choosing a Location	5
2.2	Protective Baffles.....	5
2.3	Rotary Paddle Level Switch and Vessel Preparation.....	6
3	Mechanical Installation	8
3.1	Side Mount /Top Mount	8
3.2	Extension/Guard Installation.....	8
3.3	High-Temp Models	9
3.4	Electrical connections.....	10
4	Set-up.....	12
4.1	Sensitivity (Paddle Selection)	12
4.2	Status LEDs	12
4.3	Fail-Safe	12
5	Troubleshooting	13
6	Maintenance.....	14
6.1	Fuse Replacement	14
6.2	Cleaning Requirements	14
6.3	Motor Replacement	14
6.4	Seal Replacement	15
7	Mechanicals	16
8	Safety	17
9	Specification	18
10	Warranty.....	18

1 Introduction

The Series PLS unit is a paddle-based level switch that is designed to detect high or low **levels** of free-flowing **dry solids**, such as powders and granules. It is mounted through the wall of a vessel such that the paddle protrudes inside the vessel.

A small electric motor drives a paddle that rotates freely in the absence of material, but is impeded when material is present. When the paddle is impeded, a **micro-switched output** activates to signal an alarm.

To extend the motor life, power is cut to the motor whenever the paddle is free of material. Upon contact with material, the power is restored to the motor once again, therefore rotating the paddle.

The **SafePoint model** of the PLS series unit incorporates magnetically operated detection circuits that can differentiate between paddle rotation being stopped by material presence or by electrical/mechanical failure of the unit, and then operate an independent fault relay upon detecting a failure.

Features:

- Time proven.
- Simple and reliable.
- Top or side mounting.

Applications:

- Aggregates, granular, pellets or powdered dry products.
- Dry products.
- High, intermediate or low level alarm.

1.1 Unpacking

When unpacking, you should find:

- The SafePoint Model of the Rotary Paddle Level Switch.
- This Instruction manual (IP4005).
- Safety manual (IP2004/SI) (ATEX units ONLY).

If items are missing from the box, contact the Customer Service Team at Delta Mobrey Ltd. to report the missing items and they will then advise you appropriately.

1.2 Model identification

Code	Product										
PLS	Paddle Level Switch series.										
	<table border="1"> <thead> <tr> <th>Code</th> <th>Model</th> </tr> </thead> <tbody> <tr> <td>K</td> <td>Standard model: 2 x SPDT alarm relays. *</td> </tr> <tr> <td>H</td> <td>High temperature (Hi-Temp) standard model, 2 x SPDT alarm relays. *</td> </tr> <tr> <td>P</td> <td>Failsafe SafePoint model with fault relay and 1 x SPDT alarm relay</td> </tr> <tr> <td>T</td> <td>High temperature (Hi-Temp) failsafe model with fault relay and 1 x SPDT alarm relay.</td> </tr> </tbody> </table>	Code	Model	K	Standard model: 2 x SPDT alarm relays. *	H	High temperature (Hi-Temp) standard model, 2 x SPDT alarm relays. *	P	Failsafe SafePoint model with fault relay and 1 x SPDT alarm relay	T	High temperature (Hi-Temp) failsafe model with fault relay and 1 x SPDT alarm relay.
Code	Model										
K	Standard model: 2 x SPDT alarm relays. *										
H	High temperature (Hi-Temp) standard model, 2 x SPDT alarm relays. *										
P	Failsafe SafePoint model with fault relay and 1 x SPDT alarm relay										
T	High temperature (Hi-Temp) failsafe model with fault relay and 1 x SPDT alarm relay.										
	<table border="1"> <thead> <tr> <th>Code</th> <th>Mounting</th> </tr> </thead> <tbody> <tr> <td>B1</td> <td>R 1 ½" BSPT mounting (except high temperature).</td> </tr> <tr> <td>N1</td> <td>1 ¼" NPT mounting (all models).</td> </tr> </tbody> </table>	Code	Mounting	B1	R 1 ½" BSPT mounting (except high temperature).	N1	1 ¼" NPT mounting (all models).				
Code	Mounting										
B1	R 1 ½" BSPT mounting (except high temperature).										
N1	1 ¼" NPT mounting (all models).										
	<table border="1"> <thead> <tr> <th>Code</th> <th>Housing</th> </tr> </thead> <tbody> <tr> <td>3</td> <td>Aluminium alloy housing.</td> </tr> </tbody> </table>	Code	Housing	3	Aluminium alloy housing.						
Code	Housing										
3	Aluminium alloy housing.										
	<table border="1"> <thead> <tr> <th>Code</th> <th>Voltage</th> </tr> </thead> <tbody> <tr> <td>0</td> <td>115V ac motor voltage.</td> </tr> <tr> <td>1</td> <td>240V ac motor voltage.</td> </tr> <tr> <td>2</td> <td>24V dc motor voltage (low level duties only.)</td> </tr> </tbody> </table>	Code	Voltage	0	115V ac motor voltage.	1	240V ac motor voltage.	2	24V dc motor voltage (low level duties only.)		
Code	Voltage										
0	115V ac motor voltage.										
1	240V ac motor voltage.										
2	24V dc motor voltage (low level duties only.)										
	<table border="1"> <thead> <tr> <th>Code</th> <th>Approvals</th> </tr> </thead> <tbody> <tr> <td>A</td> <td>ATEX Dust approval (pending)</td> </tr> <tr> <td>U</td> <td>US General Electric and Dust approval (pending)</td> </tr> <tr> <td>Z</td> <td>No hazardous area approvals</td> </tr> </tbody> </table>	Code	Approvals	A	ATEX Dust approval (pending)	U	US General Electric and Dust approval (pending)	Z	No hazardous area approvals		
Code	Approvals										
A	ATEX Dust approval (pending)										
U	US General Electric and Dust approval (pending)										
Z	No hazardous area approvals										

PLS	P	B1	3	1	Z
-----	---	----	---	---	---

(Typical Model Code)

* **Note:** For Standard version, refer to manual IP4004 instead of this manual.

2 Pre-installation considerations

2.1 Choosing a Location

(1) Material Flow

When selecting a location for any rotary paddle level switch, choose a point in the vessel where the paddle will be out of the direct flow of incoming and outgoing material (Figure 1); this is to prevent any mechanical damage that may be caused by the pressure of the flow. This is particularly important for materials with large, lumpy characteristics. The PLS unit must be positioned at a point where incoming material will reach and cover the paddle in its normal flow, and when receding, will flow away from the paddle in an even manner.

(2) Vibration Concerns

Mount at a location that is subject to limited vibration, away from vessel vibrators thereby attaining maximum operational life (Figure 1). Consult the factory when questionable conditions exist.

(3) Guard Reinforcement

When using rigid extensions and guards in top mounted applications, select a location where it is feasible to reinforce the guard to the vessel wall. See Mechanical Installation for further details. (See also Figure 1).

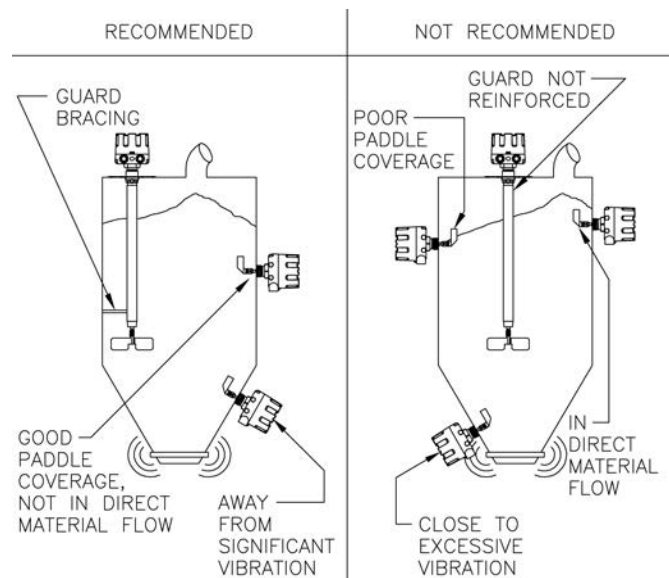

Figure 1

2.2 Protective Baffles

The installation of protective baffles for low level monitoring is recommended for materials that weigh more than 1050kg/m^3 (65 lbs/ft^3), have a tendency to pack, bridge, arch, or have unusual flow characteristics.

This baffle can be created using a number of materials including angle iron, welded plates and pipe sections. This structure will keep the full weight of the material from damaging the paddle (Figure 2).

The baffle should be welded to the bin wall and should not extend more than 152 mm (6 inches) into the vessel, as shown in Figure 2. Also, the lowest point of the baffle should be approximately 152 mm (6 inches) above the top of the paddle arc.

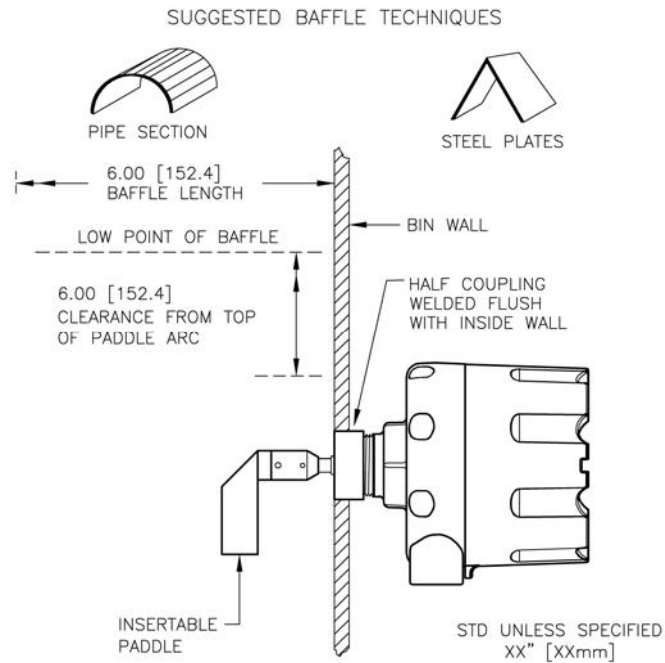

2.3 Rotary Paddle Level Switch and Vessel Preparation

(1) Mounting Plate Attachment (if applicable)

After using the **mounting plate** as a mounting hole template (see Section 3), attach the mounting plate to the PLS unit prior to attaching to vessel. This is particularly advantageous if the paddle to be used is not the insertion type. Grease the paddle unit's threaded hub with anti-seize compound and thread the mounting plate into place until snug. (See also ① of Figure 3 for guidance).

(2) Flexible Coupling Attachment (if applicable)

Remove the **lock pin** from the PLS unit. Screw the **flex coupling** into the coupling provided on the PLS unit. Align the "through hole" within the connection and secure with the lock pin. (See ② of Figure 3 for guidance).

(3) Extension Attachment (if applicable)

Remove the lock pin from the PLS unit (or flex coupling). Screw the **extension** into the coupling provided on the PLS unit (or flex coupling). Align the "through hole" within the connection and secure with the lock pin. (See also ③ of Figure 3 for guidance).

Note: Guards should be used with rigid extensions greater than 457 mm (18 inches) in length.

(4) Guard Attachment (if applicable)

In applications using a mounting plate with a **full coupling**, slide the **1 1/4" pipe** over the shaft extension and secure to the mounting plate coupling. The shaft extension should protrude, from the guard, a distance of approximately 102 mm (4 inches). (See also ④ of Figure 3 for guidance).

When not using a mounting plate, the guard must be connected to the PLS unit with a 1 1/4" full coupling and, in some cases, may require attachment *after* the PLS unit is attached to the vessel.

(5) Paddle Attachment (if applicable)

The **paddle** should be attached at this time only if it has an insertion type connection or if a mounting plate is being utilized. Remove the lock pin from the applicable connection point (i.e. PLS unit, flex coupling, or extension). Screw the paddle into the applicable coupling. Align the "through hole" within the connection and secure with the lock pin. (See also ⑤ of Figure 3 for guidance).

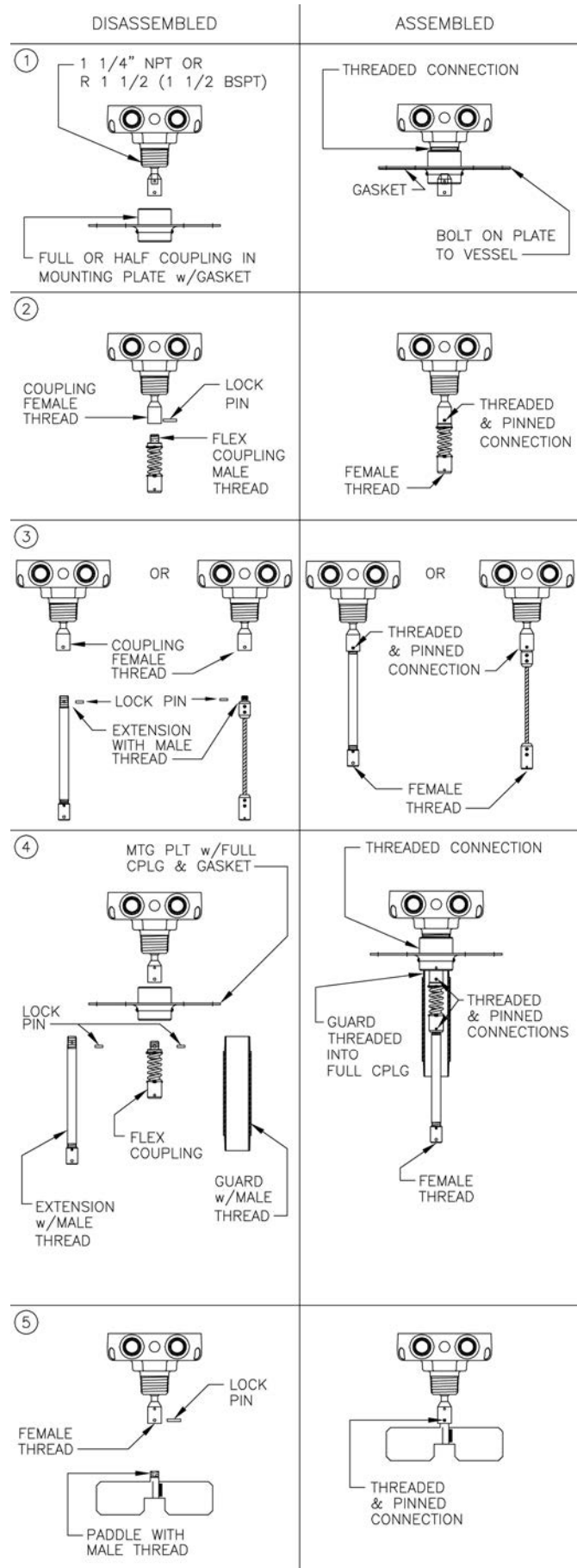

Figure 3

3 Mechanical Installation

3.1 Side Mount /Top Mount

(1) Coupling Mounting

Cut a hole into the vessel that corresponds to the outer diameter of the applicable pipe coupling.

In side-mount applications, position a **half-coupling** *flush* with the inside of the vessel and weld into place. In top-mount applications, position a **full coupling** *halfway* into the vessel and weld into place.

After greasing the mounting threads with anti-seize compound, thread the PLS unit into the coupling and position the conduit entrance to minimize moisture infiltration. Attach the paddle, if applicable. (See Figure 2 for guidance).

(2) Plate Mounting

Using the **gasket**, provided with the mounting plate, as a template, drill **six holes**. The diameters of these holes depend on the attachment method being used. Drill six clearance holes at 9 mm (11/32 inch) diameter for use with 5/16" bolts. The bolts may be secured by tack welding the bolt heads to the vessel, or by an adjoining nut.

Cut a hole, suggested size 50-125 mm or (2-5 inches), centered within the bolt circle to allow an attached paddle to fit within the bin. Attach gasket and mounting plate to the vessel, positioning the conduit entrance to minimize moisture infiltration. (See Figure 4 for guidance).

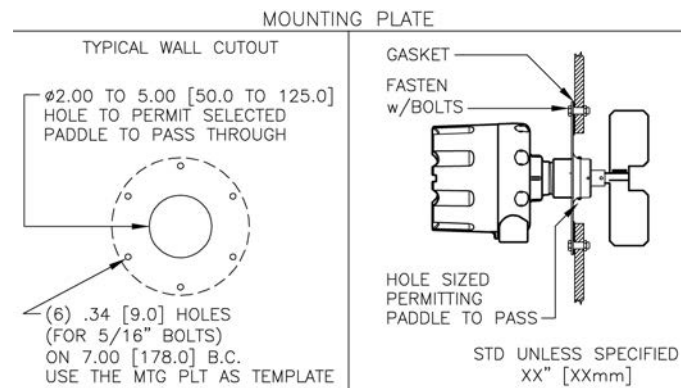

Figure 4

3.2 Extension/Guard Installation

(1) Typical Configuration

Rigid extensions are recommended for top mount applications only and should be always accompanied by a **flexible coupling**. Shaft guards are recommended whenever extensions are longer than 457 mm (18 inches). (See Figure 5 for guidance).

(2) Guard Reinforcement

Mechanical reinforcement of the shaft guard should be considered whenever a guard length greater than 1829 mm (72 inches) is used. The guard should be anchored to the sidewall with braces to reduce mechanical stress at the connection point of the guard. (See Figure 5 for guidance).

(3) Guard/Extension Multi-Stage Assemblies

It may be necessary to connect multiple short pieces of shaft extension to ultimately achieve the desired length. In all cases, extensions and guards **should not exceed** 3658 mm (144 inches). Shaft extensions can be simply connected to one another. Guards must use a 1¼" full coupling as an interface between sections. Couplings are available from Delta Mobrey Ltd. (See Figure 5 for guidance).

(4) Cable Extensions

Lengths up to 1981 mm (78 inches) are permitted, but can be shortened in the field as required. See instructions provided with cable extension for details.

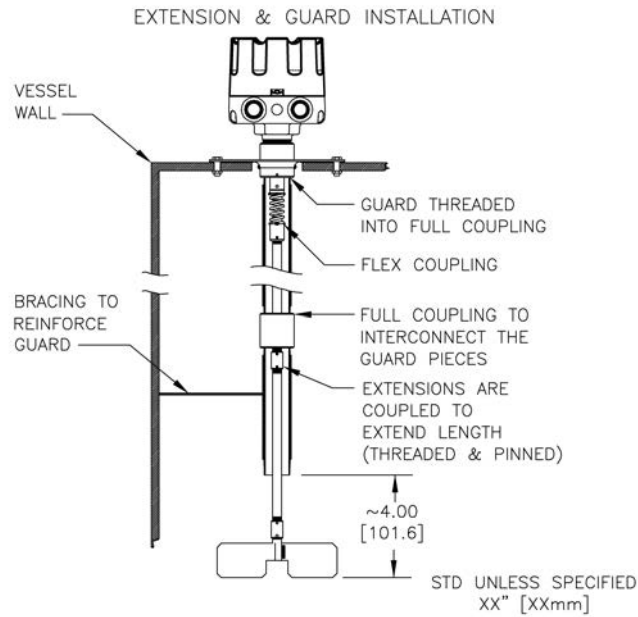

Figure 5

3.3 High-Temp Models

(1) Mounting

Carefully handle the Hi-Temp gasket provided with the assembly. Using it as a template, mark the locations of the six boltholes on the vessel. Drill six holes at the diameter applicable to the attachment method being used (i.e. tapped holes or clearance holes for bolt/nut combination).

For example, drill six clearance holes at 9 mm (11/32 inch) diameter for use with 5/16" bolts. The bolts may be secured by tack welding the bolt heads to the vessel, or by an adjoining nut. Cut a hole, suggested size 50-125 mm (2-5 inches), centered within the bolt circle to allow the paddle, when attached to PLS unit, to fit within the vessel. Attach gasket and Hi-Temp PLS unit to the vessel, positioning the conduit entrance in a manner that restricts moisture infiltration.

(2) Extensions/Guards

Use of extensions is permissible on Hi-Temp models of PLS units also. (See Section 3.2 for details of extensions). Installing guards on Hi-Temp models requires in-field modifications. Consult factory for guidance.

(3) Effective Cooling

The Hi-Temp PLS unit includes a **steel lagging pipe**, which thermally insulates (via lag pipe material and physical separation) the internal vessel temperature from the PLS unit, thereby protecting critical components. This technique is very effective but is dependent on careful consideration of ambient air temperature surrounding PLS unit, thermal conductivity of the material being sensed, and the actual temperature present at the mounting point. Table 1 is intended to provide general guidance for installation.

Each application should be evaluated to ensure that the unit's operating temperature is not exceeded. In addition, an air connection is provided on the steel lagged pipe to further increase the cooling capacity of the system. When applicable, connect airline to ½" coupling, provided on Hi-Temp model, using only the recommended air pressure, which must exceed the vessel pressure to be effective. The air should be clean and dry and is required to be continually supplied to the Hi-Temp model to assure cooling.

Table 1

Internal Temperature	Model	Air Required	CFM
150°C (< 300°F)	Standard	None	N/A
150-260°C (300-500°F)	Hi-Temp	None	N/A
260-400°C (500-750°F)	Hi-Temp	½ psig	2.14

3.4 Electrical connections

(1) Explosion Proof Precautions

Please refer to safety instruction booklet IP4004/SI when installing a PLS unit in explosive atmospheres.

(2) Factory Wiring

The PLS unit's motor leads are pre-wired to the PCB at the designations labeled "M1" and "M2". **DO NOT alter or make additional external connection to these terminals.** Doing so will likely cause damage to the PLS unit.

(3) Permanently Connected Equipment

Disconnecting devices shall be included in the system installation. In installations where multiple circuits are used, individual 'disconnects' are required. The 'disconnects' shall be within close proximity of the equipment, accessible to operators, and marked appropriately as the 'disconnect' for the associated circuit. Ensure the 'disconnect' ratings are appropriately sized for the circuit protected (see specification in Section 9).

(4) Circuit Separation

Two cable entry locations are provided to aid in maintaining separation of "hazardous live" (typically mains voltages such as 115V ac and 230V ac) and limited circuits (typically control voltages less than 30V rms or 42.4V dc). Since the PLS unit's single wiring compartment can not absolutely protect against physical contact between multiple circuits, it is required that all wiring used must have an insulation rating of 300V minimum, and a temperature rating of 80°C (176°F) minimum.

(5) Protective Earthing

Each PLS unit is provided with a "protective conductor terminal" which is terminated to the local earth ground potential. This terminal is used to eliminate shock hazard in the unlikely event of internal insulation breakdown. Select a wire size that can carry in excess of the sum of all circuit's maximum amperage.

(6) Power Input

The PLS unit is designed to accept 115V ac, 230V ac or 24v dc/ac (factory set). Verify the intended voltage supply is compatible with the voltage configuration indicated on the electronics and the external nameplate. Connect power as shown in Figure 6.

(7) Sense Output Contacts

The PLS unit is equipped with a set of isolated contacts (SPDT) which indicates whether or not material is being detected within the vessel (See Figures 6-8). This output is also influenced by the selection of the "fail-safe" switch as described in the "Setup" section of this manual. The designations on the circuit board relate to the contact status when the relay is de-energized (e.g. the material is "not" sensed and the fail-safe switch is in the "low" mode). These contacts can be connected to any type of control device, provided that ratings are observed (see specification in Section 9).

(8) Fault Output Contacts

The PLS unit is equipped with a set of isolated contacts (SPDT) that indicates whether or not the unit's self-diagnostics detected successful operation (See Figures 6-8). The designations on the circuit board relate to the contact status when the relay is de-energized (e.g. the power is removed from the PLS unit or when an internal error is detected). In normal operation, the "fault" relay will be energized resulting in a closed "normally open" contact, and an open "normally closed" contact. This output can be wired in tandem with the Sense Output Contacts to provide an output that combines the material sense and fault detection on a single wire set. See diagrams to determine what best suits the application.

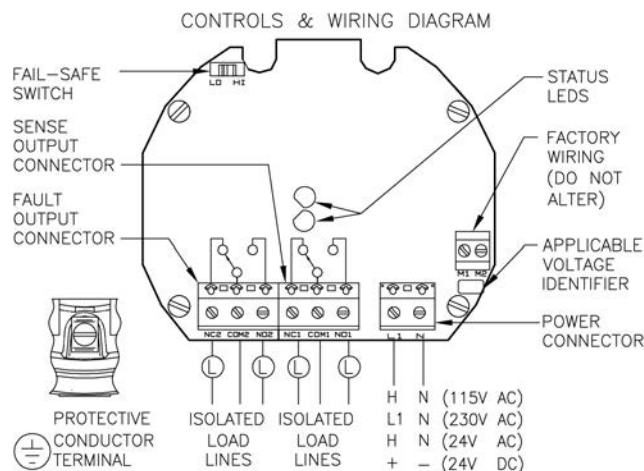

Figure 6

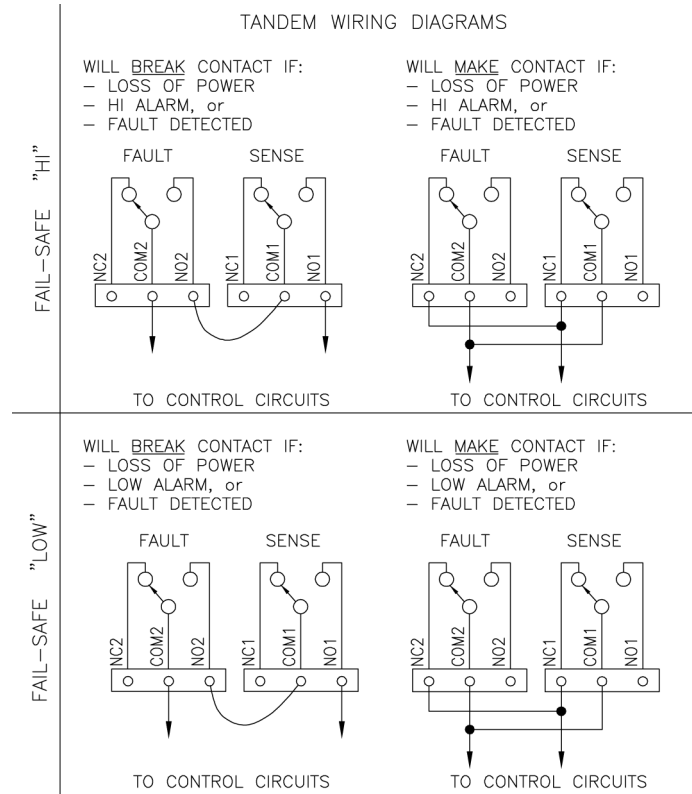

Figure 7

	INITIALIZATION	NORMAL SENSING CONDITIONS		POWER FAILURE	FAULT DETECTION
FAIL-SAFE "HI"	<ul style="list-style-type: none"> NO1 SENSE NC1 NO2 FAULT NC2 GREEN FLASH RED OFF 	<ul style="list-style-type: none"> NO1 SENSE NC1 NO2 FAULT NC2 GREEN OFF RED ON 	<ul style="list-style-type: none"> NO1 SENSE NC1 NO2 FAULT NC2 GREEN ON RED OFF 	<ul style="list-style-type: none"> NO1 SENSE NC1 NO2 FAULT NC2 GREEN OFF RED OFF 	<ul style="list-style-type: none"> NO1 SENSE NC1 NO2 FAULT NC2 GREEN OFF RED FLASH
FAIL-SAFE "LOW"	<ul style="list-style-type: none"> NO1 SENSE NC1 NO2 FAULT NC2 GREEN FLASH RED OFF 	<ul style="list-style-type: none"> NO1 SENSE NC1 NO2 FAULT NC2 GREEN OFF RED ON 	<ul style="list-style-type: none"> NO1 SENSE NC1 NO2 FAULT NC2 GREEN ON RED OFF 	<ul style="list-style-type: none"> NO1 SENSE NC1 NO2 FAULT NC2 GREEN OFF RED OFF 	<ul style="list-style-type: none"> NO1 SENSE NC1 NO2 FAULT NC2 GREEN OFF RED FLASH









Figure 8

4 Set-up

4.1 Sensitivity (Paddle Selection)

Paddle selection determines the sensitivity of the PLS unit. There is no sensitivity adjustment within the unit. Ensure that the paddle being used for the application corresponds with the recommendations found in Table 2.

Table 2

		Scimitar	Single Vane	3 Vane Standard	3 Vane Large	2 Vane	4 Vane	Triangular	Belt Vane	
										
Application (+H/L level)										
Heavy material > 2000 kg/m ³ > 40mm Ø	High								■ *	
	Low								■ *	
Heavy material > 2000 kg/m ³ < 40mm Ø	High		■ *			■ *	■ *			
	Low		■ *			■ *	■ *			
Medium material 250 - 1000 kg/m ³	High	■		■			■	■		
	Low	■	■	■			■	■		
Light material up to 250 kg/m ³	High	■			■			■		
	Low	■			■			■		
Mounting:		Insertion	Insertion	Plate or flange	Plate or flange	Plate or flange	Plate or flange	Plate or flange	Plate or flange	
Notes:		* = Flexible coupling required							■ = Recommended	

4.2 Status LEDs

Ordinary location models have LEDs located on the circuit board, which are also visible externally through the lens on the centre of the cover. On hazardous-area models, LEDs are not viewable externally.

(1) Green-flash

This indicates that "Initialisation" is in progress. For 30 seconds (maximum) after power is applied, the green LED will flash while self-diagnostics is performed. The "sense" output will indicate whether or not material is sensed in combination with the "fail-safe" switch setting. The "fault" output will remain "de-energised".

(2) Green-steady:

"No material is being sensed" and self-diagnostics has passed. The "sense" output will indicate 'no-material sensed' in combination with the "fail-safe" switch setting. The "fault" output will be "energised".

(3) Red-steady:

"Material is being sensed" and that self-diagnostics has passed. The "sense" output will indicate 'material sensed' in combination with the "fail-safe" switch setting. The "fault" output will be "energised".

(4) Red-flash:

A "fault" has been detected in the self-diagnostics. The "sense" output will default to the no-material sensed state in combination with the "fail-safe" switch setting. The "fault" output will be "de-energised".

4.3 Fail-Safe

(Use Figure 8 in conjunction with the following text).

The "fail-safe" switch setting only influences the "sense" output (never affects the "fault" output). Generally, the "fail-safe" switch is set so in the event of a power failure, the "sense" output will default to the application's critical state condition.

(1) High Fail-Safe

The "sense" output will de-energise when material is sensed at high level or with power loss.

(2) Low Fail-Safe

The "sense" output will de-energise when material is below low level or with power loss. Designations on the electronics refer to the relay contact status when no material is sensed and the "low" fail-safe is selected (Relay is de-energised). Contacts are reversed when no material is sensed and high fail-safe is selected (Relay is energised).

5 Troubleshooting

PROBLEM: The PLS unit indicates "fault" via relay output and red flashing LED.

CAUSE/SOLUTION:

- (1) Verify electrical power is connected to the proper terminations and that it is the proper voltage as depicted on the cover.
- (2) Verify that motor leads (and only the motor leads) are connected to the terminal block locations M1 and M2.
- (3) Verify voltage between the M1 and M2 positions. The voltage should be 115V ac for 115V ac models, 240V ac for 240V ac models, and 6vac for 24vdc/ac models. If correct voltage is present, motor should rotate. Replace motor if necessary.
- (4) Verify clutch operation by manually rotating paddle until motor mounting plate reaches its stops. Replace clutch if manual rotation can not cause motor mounting plate to reach stops.
- (5) Verify gap between ring magnet and small encoder PCB; gap is to be roughly 1/16". Significant misalignment will require factory evaluation and repair.

PROBLEM: The paddle does not rotate when material is absent and the sensor is in "sense" mode

CAUSE/SOLUTION:

- (1) Verify condition of sensitivity spring. It should not be cut, broken or excessively stretched to the point that it loses its ability to retract motor to "no sense" condition. Replace if necessary.
- (2) Verify status of material around shaft and hub of rotary paddle bin monitor. Excessive buildup may restrict shaft from returning to "no sense" condition. Clean material buildup.
- (3) Verify if drive shaft is free to rotate by manually twisting paddle. If rotation is restricted, replace the outer seal and the two internal bearings.

PROBLEM: The paddle rotates but material is not sensed when the paddle is covered.

CAUSE/SOLUTION:

- (1) Verify that the paddle being used in the application follows the guidelines outlined in the Delta Mobrey's Measurement's Material Characteristics Guide. Change paddle to one capable of sensing lighter material.
- (2) Verify that motor mounting plate rotates freely between its two mechanical stops. Insure spring extends uniformly without binding. Replace spring if necessary.
- (3) Verify gap between motor mounting plate and small encoder PCB; gap to be roughly 1/16". Significant misalignment will require factory evaluation and repair.

6 Maintenance

6.1 Fuse Replacement



The fuses incorporated into the PLS unit PCBs are intended for factory replacement only. If failure occurs, consult the factory for return of PLS unit, or for additional technical information.

6.2 Cleaning Requirements

The hazardous and environmental protection techniques are functional only when the cover is completely installed on to the housing. If necessary, clean the cover/housing threads to permit complete thread engagement. Do not alter the threads.

6.3 Motor Replacement

(Follow this procedure in conjunction with Figure 9).

Procedure:

- (1) Disconnect power source from PLS unit.
- (2) Disconnect motor leads that protrude from center of PCB and attach to "M1" and "M2" terminals.
- (3) Remove the four screws securing the PCB to the chassis. Pull motor leads through the grommet in the PCB. Leave power and output connections in place and drape the PCB over the side of the housing so the motor is completely accessible.
- (4) Remove the two screws holding the motor to the plastic mounting/actuator plate.
- (5) Install new motor and retain with two screws.
- (6) Pass the motor leads through the grommet in the center of the PCB. Re-attach PCB to the chassis with the four screws.
- (7) Fasten motor leads to "M1" and "M2" terminals on the PCB. Pull all excess wire up through the grommet on the PCB.
- (8) Reconnect the power source to the PLS unit.

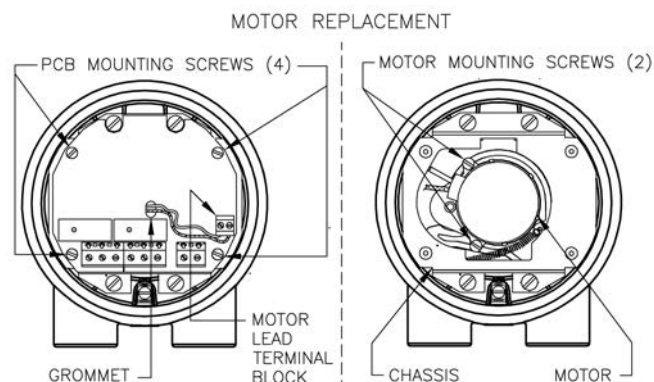

Figure 9

6.4 Seal Replacement

(Follow this procedure in conjunction with Figure 10).

Procedure:

- (1) Remove the PLS unit from the installation.
- (2) Remove coupling from drive shaft by driving out roll pin.
- (3) Remove old seal by sticking a flat blade screwdriver into the rubber and prying out of housing. Slide seal off drive shaft.
- (4) Slide new seal on drive shaft and gently press into housing.
- (5) Reinstall coupling to drive shaft and retain with roll pin. Rotate coupling to assure drive shaft rotates free in new seal.
- (6) Reinstall PLS unit.

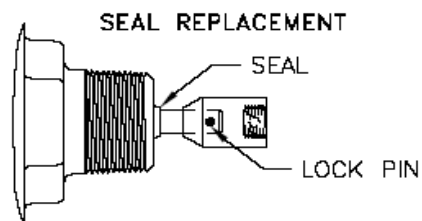

Figure 10

7 Mechanicals

NOTE: DIMENSIONS ARE SHOWN IN INCHES WITH MILLIMETER EQUIVALENT IN BRACKETS.

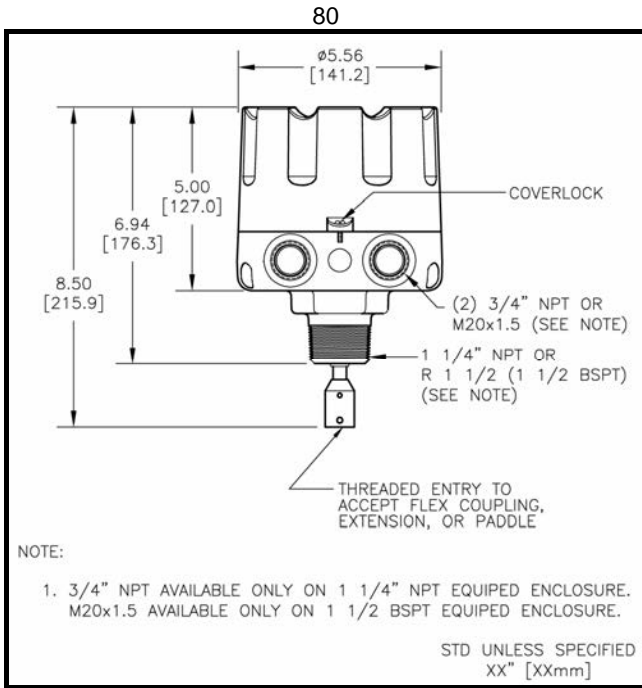

Figure 11

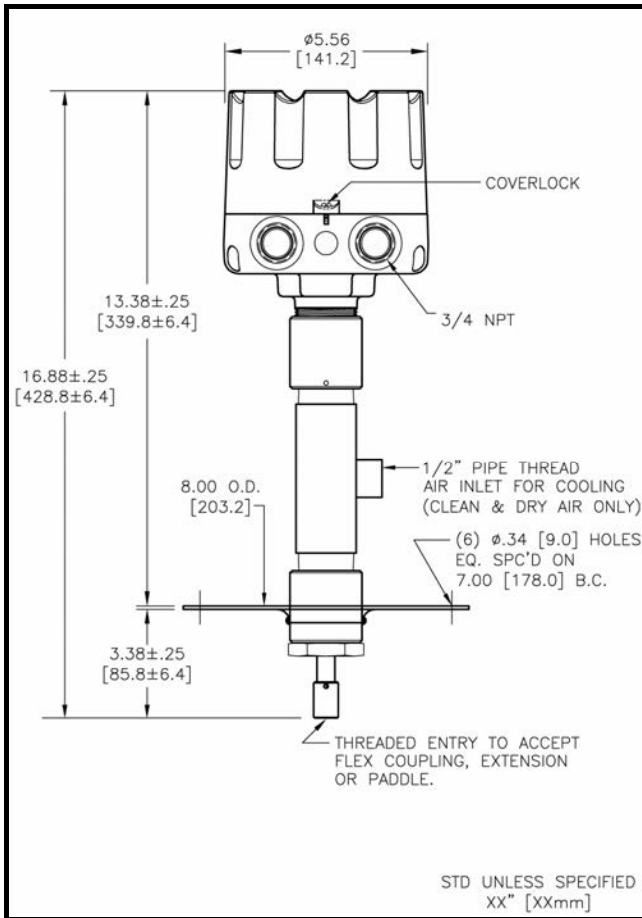
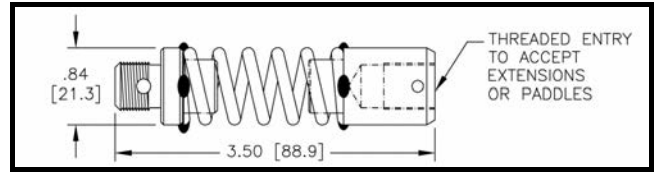
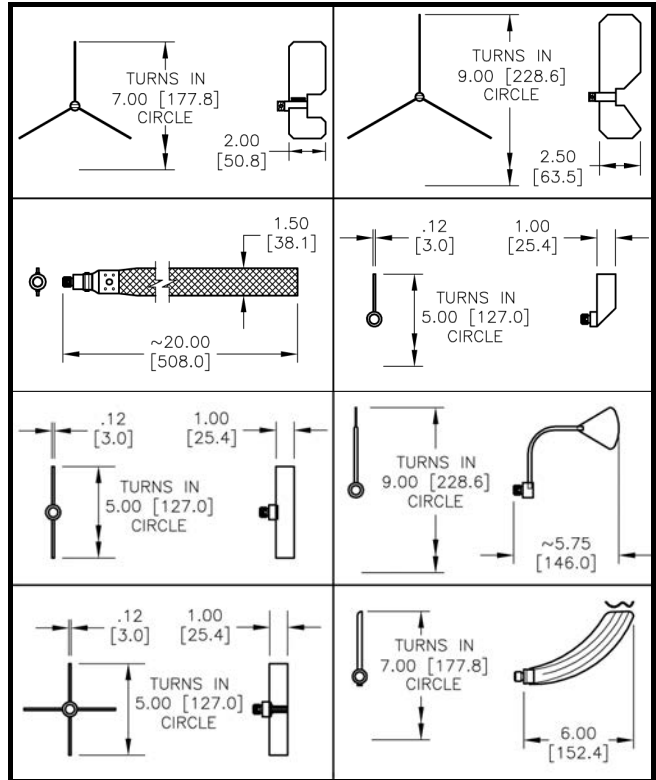

Figure 12



Flexible Coupling

Figure 13



Paddles

Figure 14

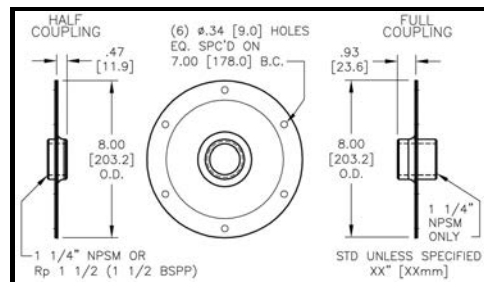

Mounting Plate

Figure 15

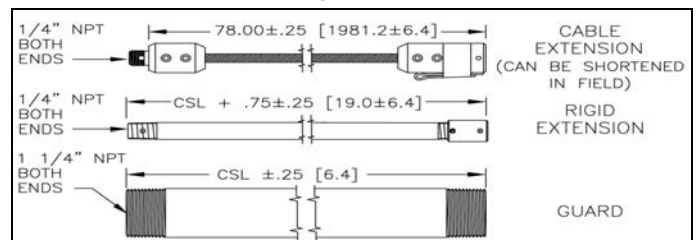

Extensions and Guards

Figure 16

8 Safety



General Safety

CAUTION: It is essential that all instructions in this manual be followed to ensure proper operation of the equipment and safety of operating personnel. The use of this symbol is used throughout manual to highlight important safety issues. Please pay particular attention to these items.



Electrical Shock Caution:

Certain PLS Series units are powered with a HIGH VOLTAGE. No operator serviceable parts are inside. All servicing is to be performed by qualified personnel. Each PLS Series unit is provided with a "protective conductor terminal" which shall be terminated to earth ground potential (see Electrical Installation).

This product's design complies with EN61010-1 installation category II and pollution degree 2.



Hazardous Location Caution

Certain PLS Series units can be used in Hazardous Locations (see specifications). These models shall only be used in applications covered by stated ratings or those considered non-hazardous. Failure to comply could result in damage to personnel and property. The following must be maintained to assure safe operation:

(1) Enclosure integrity - the PLS is manufactured from aluminium and stainless steel with nitrile rubber seals. The user or installer should consider the performance of these materials with regard to attack by aggressive substances that may be present in a hazardous location. The dimensions of the housing, cover or drive-shaft shall not be altered.

(2) Maintenance - Power to all circuits must be disconnected before conducting any investigation, setup or maintenance.

Please also refer to safety instruction booklet IP4004/SI when installing a PLS unit in explosive atmospheres.

Electromagnetic Compatibility (EMC)

The PLS Series unit was tested and found to comply with the standards listed below. It should not be used in residential or commercial environments. Compliance to the EMC standards was demonstrated by means of a test setup using the following installation methods:

(1) PLS Series unit enclosure was connected to earth ground (protective earth).

(2) No specific wiring convention was used to supply power or to retrieve output signal from the PLS Series unit.

EMC Emissions:

Meets: EN 61326-1: Electrical Equipment for Control Use, EMC.
 EN 55011: Radiated and conducted emissions (Class A - industrial).
 EN 61000-3: Fluctuations/Flicker.

Meets: FCC Part 15B: RF Devices, Unintentional Radiators.
 CISPR 11: Radiated and conducted emissions (Class A - industrial).

EMC Immunity:

Meets: EN 61326-1: Electrical Equipment for Control Use, EMC.
 IEC 61000-4-2: Electrostatic discharge (industrial).
 IEC 61000-4-3: RF radiated EM fields (industrial).
 IEC 61000-4-4: Electrical fast transients (industrial).
 IEC 61000-4-5: Electrical surges (industrial).
 IEC 61000-4-6: RF conducted EM energy (industrial).
 IEC 61000-4-8: Power frequency magnetic fields (industrial).
 IEC 61000-4-11: Source voltage deviation.

9 Specification

Power Supply:	115 V ac \pm 15%, 50/60 Hz 230 V ac \pm 15%, 50/60 Hz 24 V dc \pm 15%.
Power consumption:	4W maximum.
Outputs:	1 x SPDT control relay, 15A at 250 V ac. 1 x SPDT fault relay, 15A at 250 V ac.
Operating temperature:	-40°C to +121°C -40°C to +399°C (Hi-Temp Unit only).
Ambient temperature:	-40°C to +65°C.
Operating pressure:	2 bar maximum.
Housing material:	Aluminum alloy, powder paint coating.
Housing rating:	IP66.
Conduit connection:	Two (2) ¾" NPT <i>or</i> Two (2) M20 cable glands.
Mounting Connection:	1 ¼" NPT <i>or</i> R 1 ½ BSPT (except Hi-Temp unit).
Weight:	Typical standard model is approximately 4 kg.
Wetted parts:	Type 304 Stainless Steel
Approvals:	ATEX II 1/2 D T 100°C
(Pending)	<i>UL and CSA Class I, Div. 1 & 2, Groups C, D. Class II, Div. 1 & 2, Groups E, F, G</i>
Sensitivity:	80 kg/m ³ minimum material density (when using large 3-vane paddle).

10 Warranty

Delta Mobrey Ltd. warrants each PLS Series unit to be free from defects in material and workmanship under normal use and service within two (2) years from the date of purchase (DC motors are warranted for six (6) months from the date of purchase). The purchaser must give notice of any defect to Delta Mobrey Ltd. within the warranty period, return the product intact and prepay transportation charges.

The obligation of Delta Mobrey Ltd. under this warranty is limited to repair or replacement at its factory. This warranty shall not apply to any product which is repaired or altered outside of the factory, or which has been subject to misuse, negligence, accident, incorrect wiring by others or improper installation.



Delta Mobrey Ltd. reserves the right to change the design and/or specifications without prior notice.

Level

Head Office (UK)

Delta Mobrey Limited

Hudson House, Albany Park
Camberley Surrey, GU16 7PL, UK.

-  +44 (0)1252 729140
-  +44 (0)1252 729168
-  sales@delta-mobrey.com



[Linkedin.com/company/delta-mobrey-ltd](https://www.linkedin.com/company/delta-mobrey-ltd)



[Twitter.com/DeltaMobreyUK](https://twitter.com/DeltaMobreyUK)



[Facebook.com/DeltaMobreyUK](https://www.facebook.com/DeltaMobreyUK)

Standard Terms and Conditions of Sale can be found
at: www.delta-mobrey.com