

# Technical Datasheet



## Hydrastep 2468 (SIL 2 capable)

### Steam drum level indication

#### Key Features

- For use with 8 to 32 electrode inputs
- SIL 2 capable for use in a Safety Instrumented Function
- High clarity local and remote displays
- 32 segment green/red display of the water/steam interface level
- 4–20 mA output proportional to water/steam interface level
- Relay output option for high or low level alarms or trips
- Dual redundancy option for ultimate reliability
- Detect and indicate any fault conditions
- Contamination indication for preventative maintenance
- For use to 560 °C (1040 °F) and 300 Bar (4350 PSI)
- PED compliant as a Safety Accessory
- FM approved for boiler control
- Hazardous area approved

#### Series Overview

The Hydrastep 2468 is the modern day equivalent of the site glass to monitor, display and output the level of the water/steam interface. For use on water tube boiler steam drums and de-aerators, the Hydrastep name has become synonymous with steam drum level measurement and through its evolution has ensured plant safety globally for more than five decades.

Assessed by an external body and found to be SIL 2 capable according to the requirements of IEC 61508. Recognised by boiler inspectors and plant insurers, the ASME approved design ensures Hydrastep can be used as a Remote Level Indicator in compliance with ASME Boiler Code PG60.1.1. Approved by Factory Mutual for boiler level control and recommended within the UK's Combustion Engineering Association's water tube boiler guide BG11.

#### Other products

Other products we can offer :

- Hydratect for water and steam detection
- Boiler Level Controls
- D Series Differential Pressure transmitter



#### Product applications

- Electronic gauging system for Water Tube Boilers
- Steam drum or de-aerator drum level monitoring
- Control room level indication
- Level alarms and trips
- 4-20mA output proportional to water/steam interface level
- SIL 2 capable according to IEC 61508
- For use in a Safety Instrumented Function (SIF)
- Part of an ASME PG60.1.1 compliant system
- Recommended within the UK's Combustion Engineering Association's BG11

#### How can we help you?

Delta Mobrey offers fast, efficient and knowledgeable support when and where you need it. Please visit our web site at [www.delta-mobrey.com](http://www.delta-mobrey.com) to find your local support centre or call us on:

**+44 (0)1252 729140**

Hydrastep: Steam Drum Level Indication

Model: 2468

## Hydrastep 2468: How to order

Hydrastep is a system comprised of

- A) a Water Column
- B) a set of Electrodes
- C) one or more Cables
- D) a Control Unit,
- E) an optional Remote Display.

*Please use the tables below to configure a system to suit your needs.  
Contact our Sales engineers if support is needed need.*

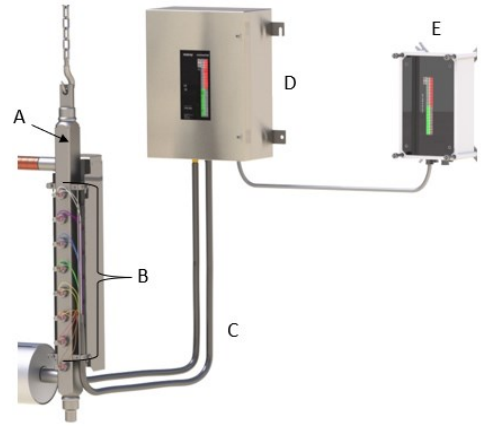

## A) How to order a Water Column

*The water column can be configured by selecting codes representing features from the tables that follow.*

*For assistance in configuring a water column that best suits your needs, please contact your local sales office*

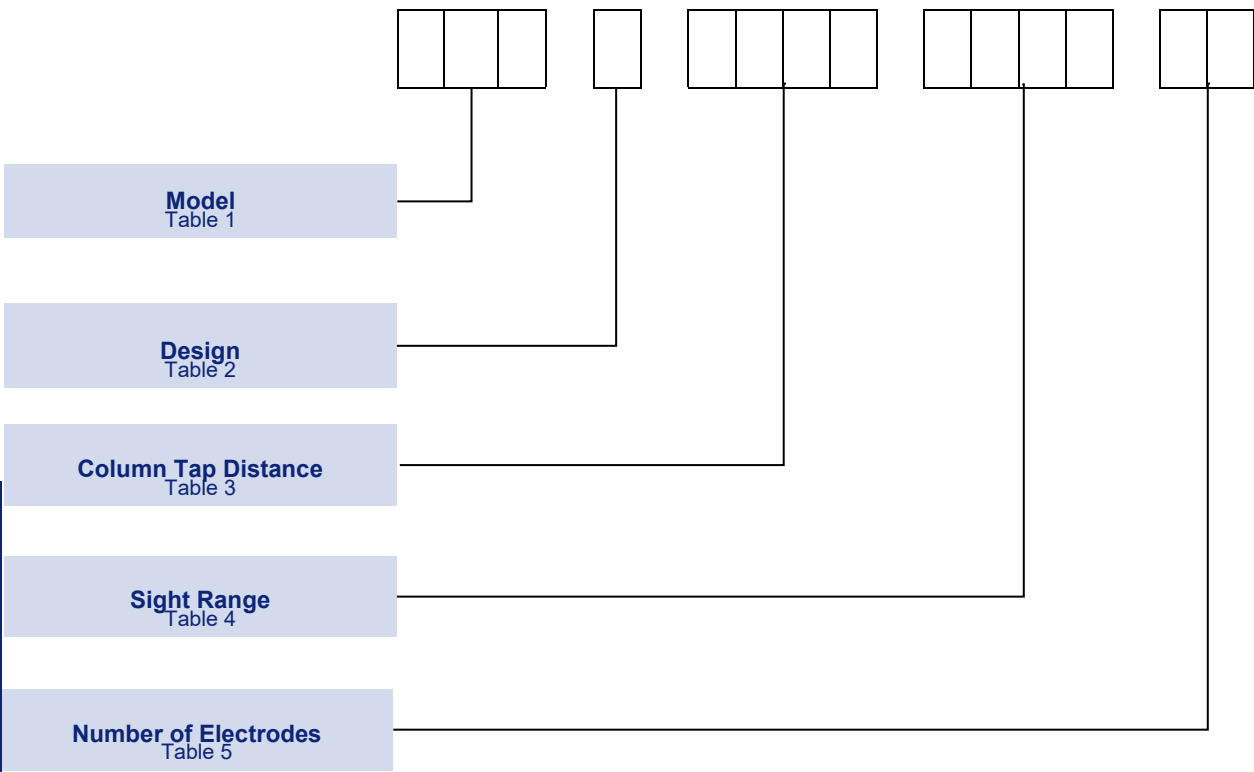

Hydrastep: Steam Drum Level Indication  
Model: 2468

## Models

Description	Code
Low pressure column, 120 bar max, 343°C max Uses electrode 459600602	120
High pressure column, 210 bar max, 370°C max Uses electrode 246781ZA	210
Super critical column, 300 bar max, 560°C max Uses electrode 246785A	300

**Design**

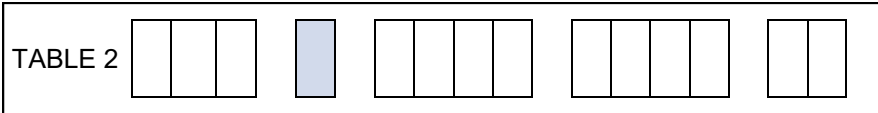

Description	Code
Side-arm design (side-side process connections)	No code used
In-line design (top and bottom process connections)	L

**Tap Distance**

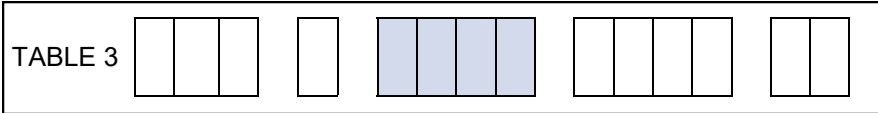

Description	Code
Distance between the centres of the side-side process connections, (or top and bottom connections for 'in-line') in mm or inches	TTTT

**Sight Range**

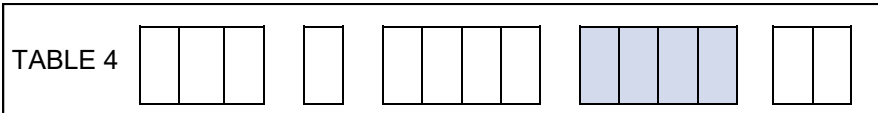

Description	Code
Distance between the highest and lowest electrodes (sight range) in mm or inches	SSSS

**Number of Ports**

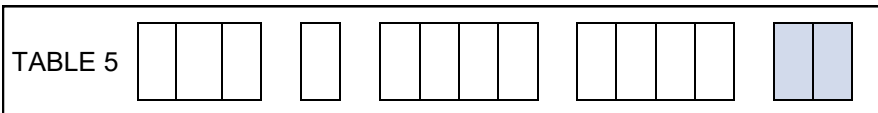

Description	Code
Number of electrode ports (must be an even number from 8 to 32)	XX

*Prior to placing an order, a Water Column Design Sheet must be completed to capture all the design requirements (consult your sales office).*

## B) How to order Electrodes

The electrode must be selected to match the water column connection from the table above. Electrodes are selected by part numbers having from 7 to 9 digits. Refer to the tables below.

--	--	--	--	--	--	--	--	--	--

**Electrode part number**  
Table 1

### Electrodes

TABLE 1									
---------	--	--	--	--	--	--	--	--	--

Description	Code
Low pressure threaded electrode, M18 thread (includes gasket) Maximum pressure 120 bar, maximum temperature 370°C Zirconia insulator, pH range 7-11	459600602
High pressure electrode, Swagelok style union (gasket not required) Maximum pressure 210 bar, maximum temperature 370°C Zirconia insulator, pH range 7-11	246781ZA
Super critical electrode, Swagelok style union (gasket not required) Maximum pressure 300 bar, maximum temperature 560°C, ZTA insulator, pH range 7-11	246785A

## C) How to order Cables

High temperature resistant multicore cables. Refer to the table below. For 8 to 16 electrodes, 2 cables are required. For 18 to 32 electrodes, 4 cables are required

--	--	--	--	--	--	--	--	--	--

**Cable**  
Table 1

**Length**  
Table 2

### Electrode cable

TABLE 1									
---------	--	--	--	--	--	--	--	--	--

Description	Code
Hydrastep multicore electrode cable	2468020

### Cable length

TABLE 2									
---------	--	--	--	--	--	--	--	--	--

Description	Code
3 metre (10 ft) multicore cable (for up to 8 electrodes)	4A
10 metre (33 ft) multicore cable (for up to 8 electrodes)	5A
18 metre (60 ft) multicore cable (for up to 8 electrodes)	6A
30 metre (98 ft) multicore cable (for up to 8 electrodes)	7A

Hydrastep: Steam Drum Level Indication  
Model: 2468

## D) How to order a Control Unit

The control unit can be configured by selecting codes representing the desired features from the tables that follow.

The chart below, describes how the model code is built up. For assistance in configuring a control unit that best suits your needs, please contact your local sales office.

Note: all model options are SIL 2 capable.

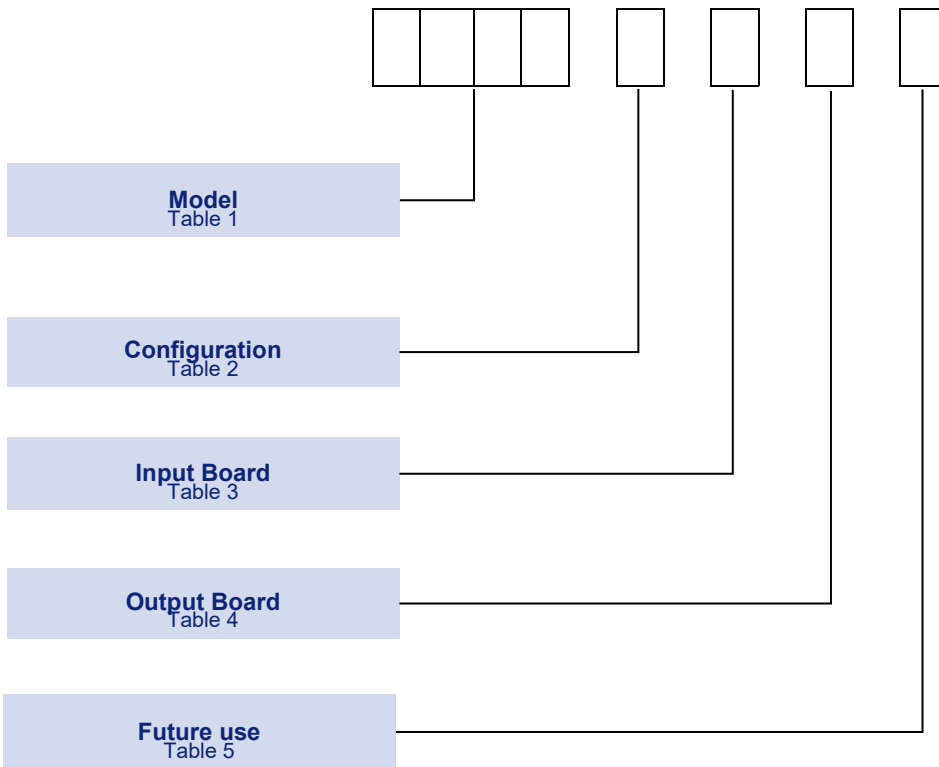

### Base model

TABLE 1	<input type="checkbox"/>	<input type="checkbox"/>	<input type="checkbox"/>	<input type="checkbox"/>	<input type="checkbox"/>	<input type="checkbox"/>	<input type="checkbox"/>
---------	--------------------------	--------------------------	--------------------------	--------------------------	--------------------------	--------------------------	--------------------------

Description	Code
Hydrastep Control Unit	<b>2468</b>

### Configuration

TABLE 2	<input type="checkbox"/>	<input type="checkbox"/>	<input type="checkbox"/>	<input type="checkbox"/>	<input checked="" type="checkbox"/>	<input type="checkbox"/>	<input type="checkbox"/>
---------	--------------------------	--------------------------	--------------------------	--------------------------	-------------------------------------	--------------------------	--------------------------

Description	Code
Standard Product	<b>C</b>

Hydrastep: Steam Drum Level Indication  
Model: 2468

**Input Board(s)**

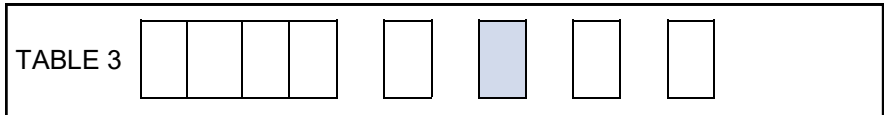

Description	Code
Single input board, 8 to 16 electrodes Single a.c. mains power supply	<b>A</b>
Dual input board, 8 to 32 electrodes Dual a.c. mains power supplies	<b>B</b>
Single input board, 8 to 16 electrodes Single 24V d.c. mains power supply	<b>C</b>
Dual input board, 8 to 32 electrodes Dual 24V d.c. mains power supplies	<b>D</b>
Dual input board, 8 to 32 electrodes Single a.c mains & single 24V d.c. mains power supplies	<b>E</b>

**Output Board(s)**

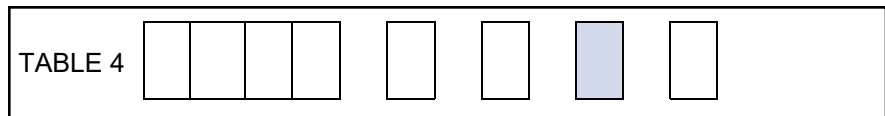

Description	Code
No output board	<b>A</b>
1 relay output board with 4 relays (only for single input board)	<b>B</b>
2 relay output boards with 8 relays, (for single or dual input boards)	<b>C</b>
4 relay output boards with 16 relays (only for dual input boards)	<b>D</b>
1 relay output board with 4 time delay relays (only for single input board)	<b>E</b>
2 relay output boards with 8 time delay relays (for single or dual input boards)	<b>F</b>
4 relay output boards with 16 time delay relays (only for dual input boards)	<b>G</b>

**For future use**

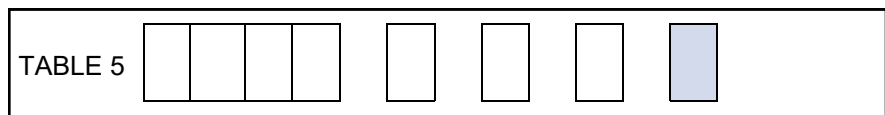

Description	Code
Special option	<b>D</b>

## E) How to order remote Displays

Up to six remote displays can be used with one controller. One remote display can be powered from the controller, but any further displays must be powered by a local supply (nominal 24Vdc)

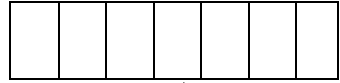

Remote display part number  
Table 1

### Remote displays

TABLE 1	
---------	--

Description	Code
Remote display for use with Hydrastep 2468 systems	24683

### Installation

TABLE 1	
---------	--

Description	Code
32 LED remote display, small panel mount (DIN 43700 / IEC 61554)	BB
32 LED remote display, large panel mount (DIN 43700 / IEC 61554)	C
32 LED remote display, IP65 wall mount	D

Hydrastep: Steam Drum Level Indication  
Model: 2468

<b>Installation Accessory</b>	
<b>Accessory</b>	<b>Code</b>
Electrode thread anti-seize compound (recommend one per water column)	830007220

<b>Spares and Replacement Parts</b>	
<b>Controller parts</b>	<b>Code</b>
Accessory Kit (ac supply input boards) A complete set of connectors, links and fuses as supplied with the controller	24680233AVV
Accessory Kit (dc supply input boards) A complete set of connectors, links and fuses as supplied with the controller	24680234AVV
Spare or expansion 220/110 Vac input board (for 16 electrode inputs)	24680501CVV
Spare or expansion 24Vdc input board (for 16 electrode inputs)	24680516BVV
Spare display board	24680515BVV
Spare or expansion relay board	24680504CVV
Spare or expansion time delay relay board	24680509BVV
Fuse: 200mA for 220Vac operation	K9634
Fuse: 400mA for 110Vac operation	K9635
Fuse: 1.25A for 24Vdc operation	360190320
<b>Water column</b>	<b>Code</b>
Low pressure electrode spare gasket (for electrode 459600602)	470112950
Low pressure blanking plug	24569A
High pressure blanking plug	450600880
<b>Recommended Spares</b>	
Start-Up and Commissioning: for each Hydrastep system it is recommended to have:	
<ul style="list-style-type: none"> <li>• quantity of 25% spare electrodes per water column</li> <li>• a complete set of spare gaskets for low pressure electrodes</li> <li>• two spare fuses according to the input board supply voltage</li> </ul>	
For two years operation it is recommended to have:	
<ul style="list-style-type: none"> <li>• quantity of 100% spare electrodes per water column</li> <li>• a complete set of spare gaskets for all low pressure electrodes</li> <li>• two spare fuses according to the input board supply voltage</li> <li>• one spare input board per three systems (two for dual input controllers)</li> <li>• one spare display board per three systems</li> <li>• one spare relay board per three systems</li> <li>• spare electrode cable, same length as ordered</li> </ul>	
<b>Note: contact your local Delta Mobrey sales office for local service support in your area</b>	



## Technical Specification

<b>Water columns – all models</b>			
Process connections		Flanged or weld prepared (refer to design sheet for options)	
Electrode ports		From 8 to 32	
Design code		ASME B31.1 power piping	
Manufacture and test		In accordance with ASME Boiler and Pressure Vessel Code, Section 1	
Material certification		In accordance with BS EN10204 3.1	
Test pressure		1.5 x design pressure	
Maximum length		3500mm (138 inches)	
Protective covers		18 SWG (17 AWG) stainless steel	
<b>Low Pressure Systems: Maximum 120 bar and 343 deg C</b>			
Low Pressure Water columns 120-TTTT-SSSS-XX		Low Pressure Electrodes 459600602	
Design Pressure	120 bar (1740 psi)	Design Pressure	120 bar (1740 psi)
Temperature	343°C (650°F)	Temperature	370°C (698°F)
Materials	Carbon Steel ASTM A105 / A106 GR B	Insulator	Zirconia
Electrode ports	M18 inch female thread	Thread	M18 inch male thread
Weight <sup>1</sup>	12 kg (26.5 lb)		
<b>High Pressure Systems: Maximum 210 bar and 370 deg C</b>			
High Pressure Water columns 210-TTTT-SSSS-XX		High Pressure Electrodes 246781ZA	
Pressure	210 bar	Pressure	210 bar
Temperature	370°C (698°F)	Temperature	370°C (698°F)
Materials	Carbon Steel ASTM A105 / A106 GR B body SA 479—316N electrode mounts	Insulator	Zirconia
Electrode ports	Swagelok style ¾" male thread	Thread	Swagelok style ¾" female thread
Weight <sup>1</sup>	17kg (37.5 lb)		
<b>Super Critical Systems: Maximum 300 bar and 560 deg C</b>			
Super Critical Water columns 300-TTTT-SSSS-XX		Super Critical Electrodes 246785A	
Pressure	300 bar (4350 psi)	Pressure	300 bar (4350 psi)
Temperature	560°C (1040°F)	Temperature	560°C (1040°F)
Materials	Stainless steel ASTM A312 / A182 F316 With SA479-316N electrode inserts	Insulator	Zirconia toughened Alumina (ZTA)
Electrode ports	Swagelok style 1/8" male thread	Thread	Swagelok style 1/8" female thread
Weight <sup>1</sup>	17kg (37.5 lb)		

1. Typical for 610mm (24 inch) steam/water range and 12 ports, including electrodes and covers

<b>Hydrastep Control Unit 2468C***</b>		<b>Relay Output boards (for alarms or trips)</b>	
Inputs	8 to 16 electrodes (single input board) 8 to 32 electrodes (dual input board)	Each relay output board	Four SPCO relays
Water/Steam threshold	Default 0.6 $\mu\text{S}/\text{cm}$ , configurable to 1.6 $\mu\text{S}/\text{cm}$	Relay contact rating (ac)	Maximum voltage 250 Vac Maximum current 8A Maximum switching power 1500 VA
Water conductivity	Default up to 104 $\mu\text{S}/\text{cm}$ . Configurable to 300 $\mu\text{S}/\text{cm}$ and 1600 $\mu\text{S}/\text{cm}$	Relay contact rating (dc)	Maximum voltage 125 Vac Maximum switching power 240W <30V, 8A (resistive), 25W < 125V Minimum switching capacity 10mA @ 5 Vdc Type N safety: maximum current 100mA
Control unit operating temperature	-20 to 65 °C (-4 to 149 °F)	Time delay relay board	0 to 25s +/- 1s
Relative humidity	100%	<b>Remote displays 24683**</b>	
Enclosure	S.S.304, IP65, (12 kg) (Refer dimensional drawing)	Power supply	20 to 54Vdc
Power supply (ac)	94V to 130V or 187 to 256V, 48Hz to 65Hz 60VA max	Cable distance	1000 meters maximum Fibre optics possible
Power supply (dc)	20V to 40V negative ground isolated, 60W max	Number of remote displays	Up to six, one powered from the control unit
Analogue output	4-20mA or 0-20mA, forward or reverse.		
Analogue output drive	600 ohms at nominal supply, 500 ohms at minimum supply		
Analogue output accuracy	+/- 0.2mA		
Resolution	Dependent on distance between electrodes		
Display output	Up to 6 remote displays One powered from the controller, remaining displays powered locally. Maximum 1000m cable length (cable not supplied)		

## Approvals

### EUROPEAN DIRECTIVES

#### **Electromagnetic Compatibility Directive (EMC) 2014/30/EU**

Compliant to EMC directive

#### **Low Voltage Directive (LVD) 2014/35/EU**

Compliant to LVD directive

#### **Pressure Equipment Directive (PED) 2014/68/EU:**

This product is categorised as a Safety Accessory

Certificate no.

120 bar:- IES/CAT000530347-B1-2

210 bar - IES/CAT000530347-B1-1

300 bar - IES/CAT000530347-B1-3

#### **ATEX Directive 2014/34/EU**

NON SPARKING

EN 60079-0, EN 60079-15



II 3G Ex nA IIC T4 Gc X (-20°C ≤ Ta ≤ +65°C)

### GLOBAL CERTIFICATION

#### **CSA (Canada and USA)**

C22.2 No.0, C22.2 No.142, CSA E60079-15, C22.2 No.213

UL 916, UL60079-15, UL 1604, ISA 12.12.01

Ex nA [nL] nL IIC

Class 1 Zone 2, AEx nA IIC with relay output connected only to energy limited circuits

#### **SAFETY INTEGRITY LEVEL**

IEC 61508 parts 1 and 2

SIL 2 capable on 4-20mA output(s)

Certificate number K066\_CT001 issued by Engineering Safety Consultants

#### **FM**

FM 7710

Approved for boiler water-level control

**Dimension Drawing**

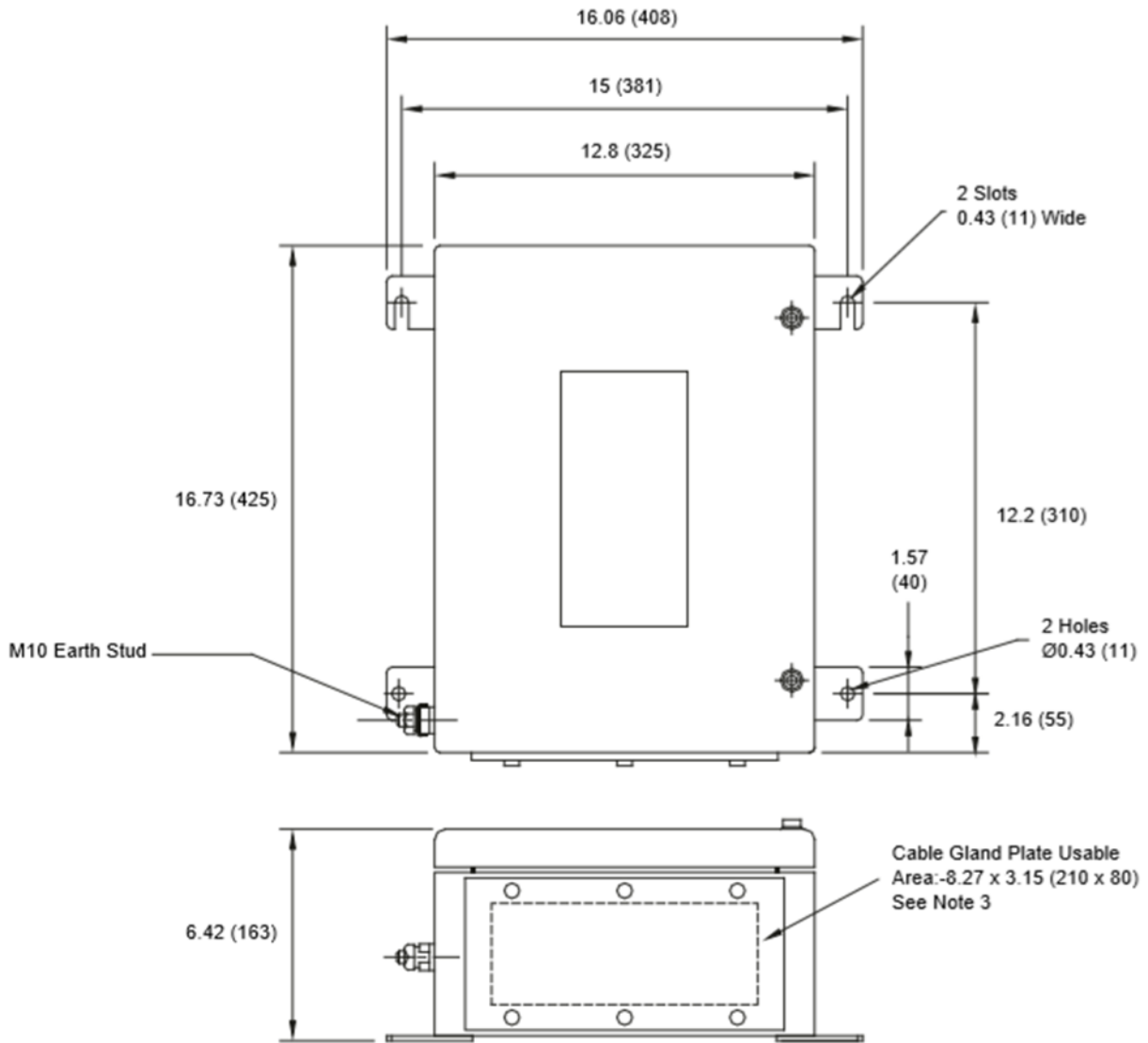

Hydrastep 2468C\*\*\* enclosure

NOTES:

1. Weight: 12kg
2. IP Rating: IP65
3. Material thickness between cable glands must be 9mm minimum
4. Enclosure: Stainless steel

Hydrastep: Steam Drum Level Indication  
Model: 2468

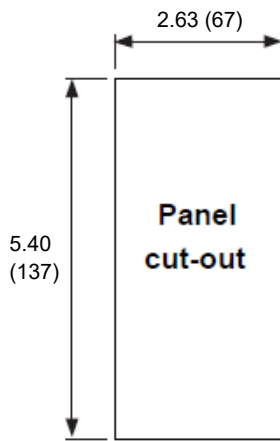
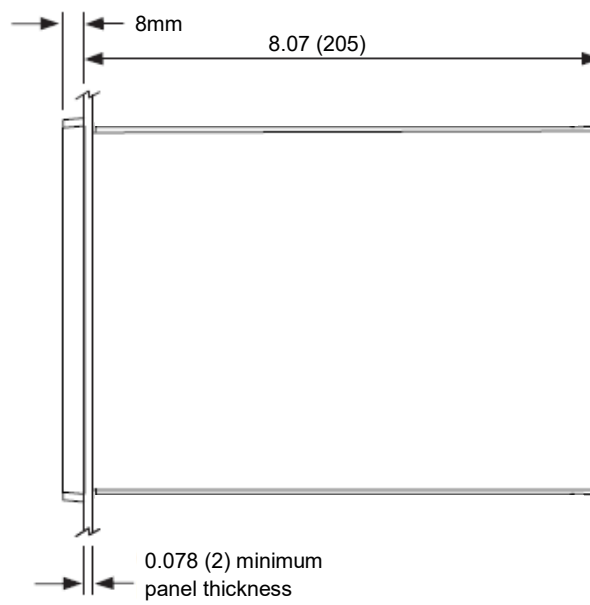
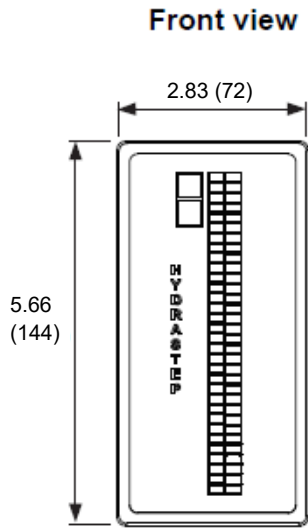

**Rear view**

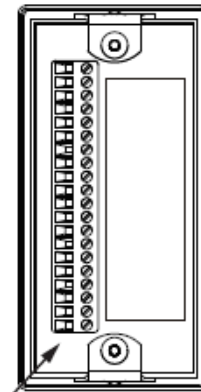

Small panel mount 24683BB

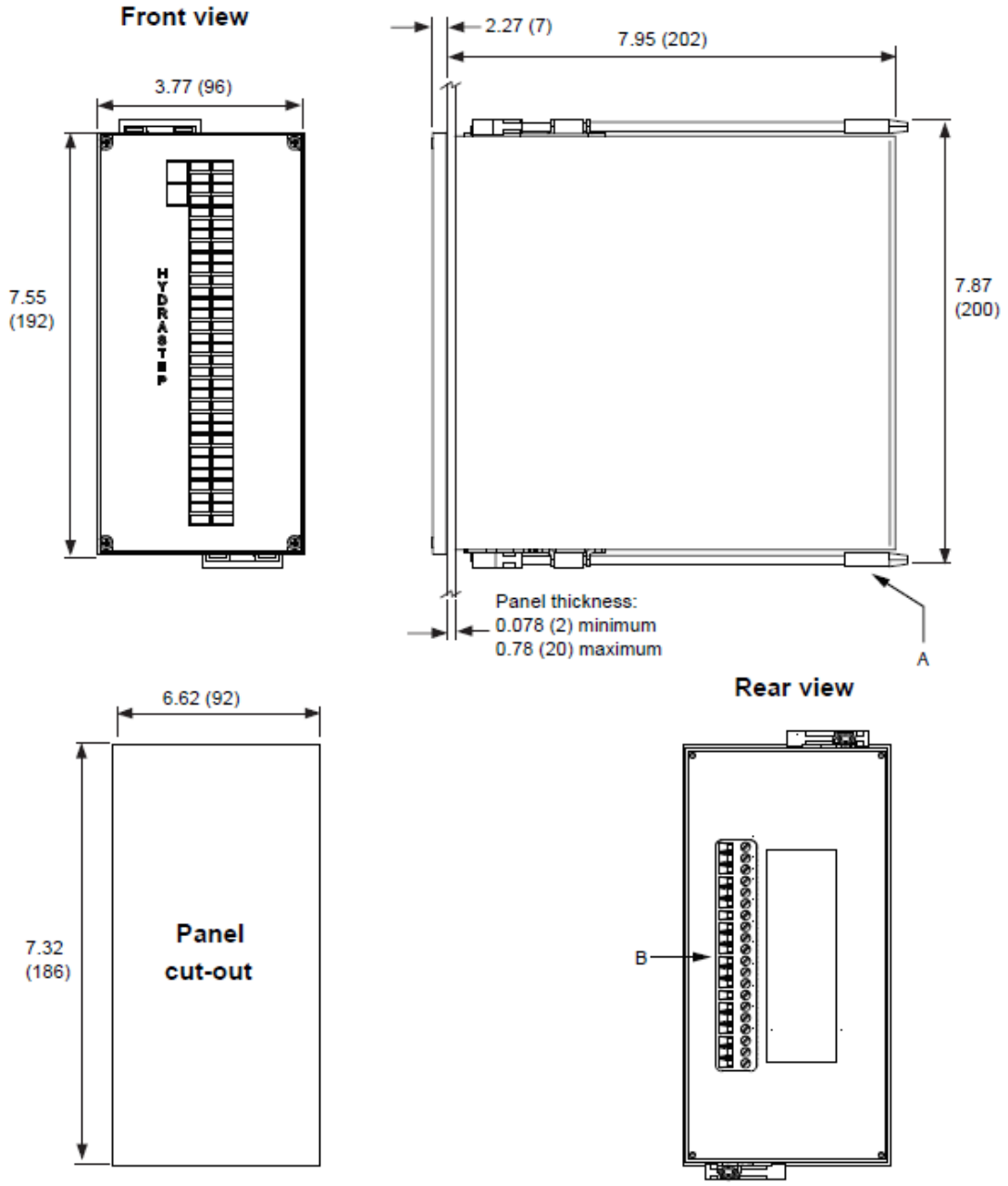

- A. Panel retaining clamps (two positions)
- B. Input terminals

Large panel mount 24683C

Hydrastep: Steam Drum Level Indication  
Model: 2468

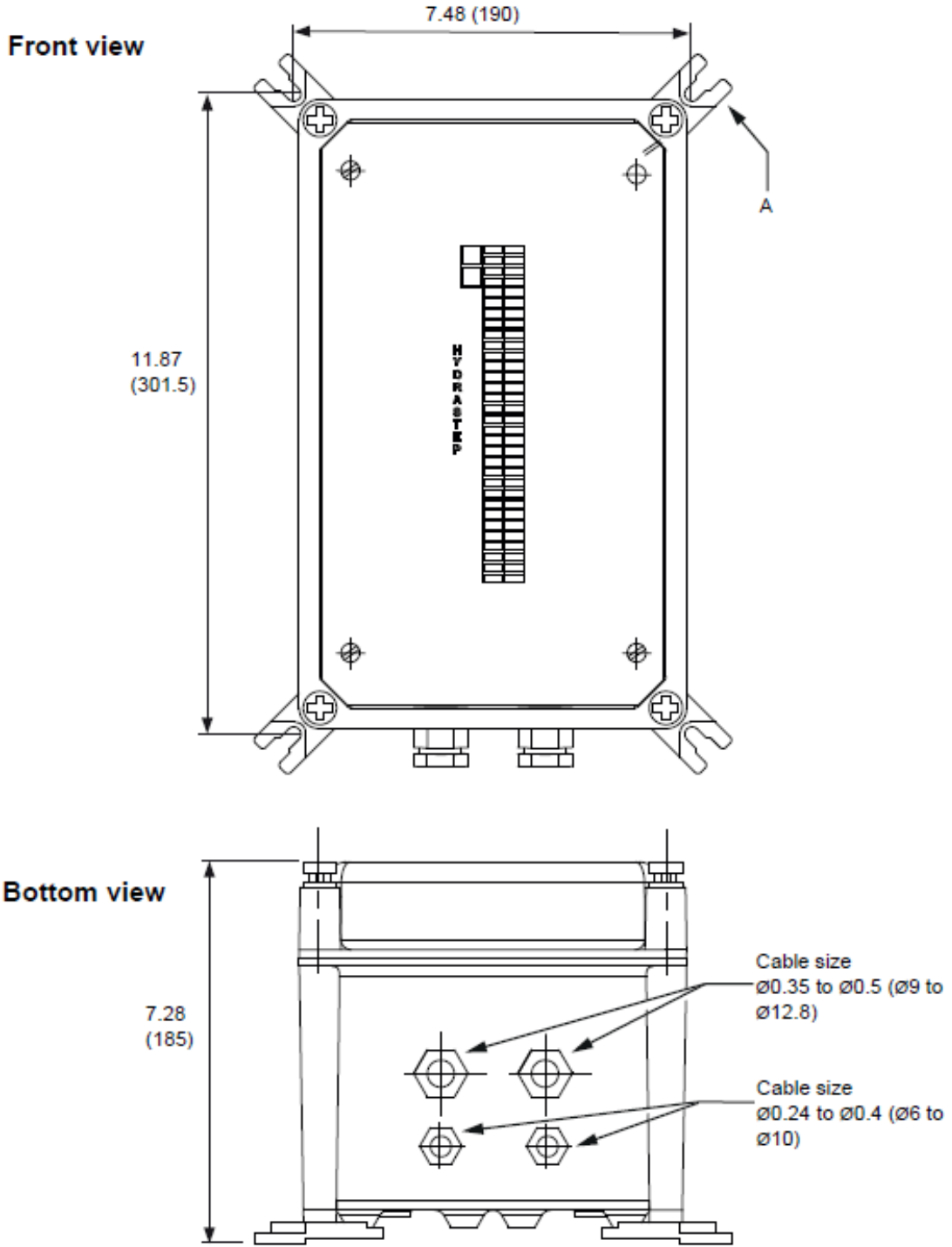

A. Wall mounting points (four positions)

Dimensions are in inches (mm).

### Wall mount 24683D

*In the interest of development and improvement Delta Mobrey Ltd, reserves the right to amend, without notice, details contained in this publication. No legal liability will be accepted by Delta Mobrey Ltd for any errors, omissions or amendments.*

**Delta Mobrey Limited**  
 Riverside Business Park, Dogflud Way, Farnham, Surrey GU9 7SS, UK.  
 T+44 (0)1252 729140 F+44 (0)1252 729168 E sales@delta-mobrey.com W www.delta-mobrey.com



FM00720