

Technical Datasheet



D Series SMART Pressure Transmitter

Model: D21



Key Features

- ATEX - Flameproof and Intrinsically Safe
- IECEx - Flameproof and Intrinsically Safe
- SIL 2 certificate
- Compliant to NAMUR NE-43
- High accuracy $\pm 0.075\%$ (better accuracy upon request)
- Fully HART ® compatible
- Static pressure limit up to 1200 bar
- 4-20mA, 0-20mA or 0-5mA analogue with digital communications
- Gold (Au) plated diaphragm option
- Hastelloy C276 wetted part option
- Programmable range, zero shift, characteristic and damping ratio with local panel keys
- Lightweight
- Linearisation of output signal on 20 point curve for specific applications is available
- Write protection option through the D-COMM communicator, 'D-Soft' program or software using library EDDL



Product applications

The D Series SMART Pressure Transmitter is suitable for a wide range of applications in:

- Oil & Gas
- Chemical
- Petrochemical
- Power

The choice of models available ensures that the Delta Transmitter is suitable for use in:

- Corrosive atmospheres
- Resistant to chemical attack

Series Overview

The D-Series pressure, differential pressure and temperature transmitters offer customers reliable and accurate solutions to their individual process requirements. Available with a wide range of process connections and easily configurable via the D-Soft software, the D-Series can be used for a variety of applications when pressure, differential pressure, temperature, level or flow measurements are needed.

Other products in the series include:

- SMART Differential Pressure Transmitter
- SMART Differential Pressure Transmitter with 2 remote chemical seals
- SMART Temperature Transmitter



How can we help you?

Delta Mobrey's offers fast, efficient and knowledgeable support when and where you need it. Please visit our website at www.delta-mobrey.com to find your local support centre or call us on:

+44 (0) 1252 729140

D-Series
Model: D21

How to order

Transmitters can be configured by selecting codes representing the desired features from the tables that follow. The chart below, describes how the model code is built up. For assistance in configuring a transmitter that best suits your needs, please contact your local sales office.

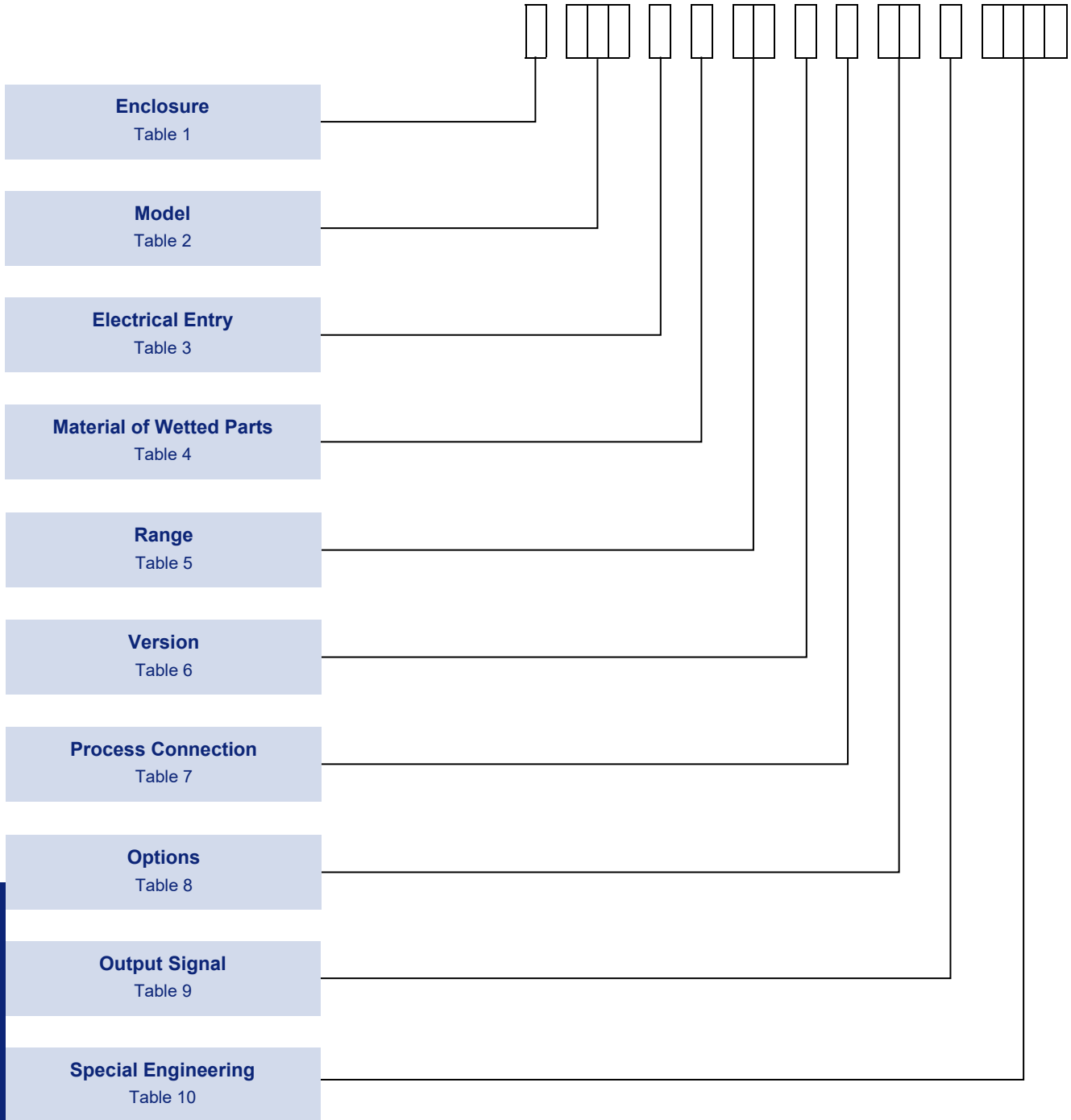

NOTE 1: Only the most common options are shown in this datasheet. Should you require a feature that is not shown, please contact your local sales office for further details.

NOTE 2: The non-standard option code is shown by "X" in the part number. Should you require any clarification on this codes please contact your local sales office.

NOTE 3: Please confirm before ordering if the backlight of the display is required to be settled differently from our standard. It cannot be successively settled in field.

- Instruments in Std, Exd, Exi construction are normally supplied with backlight ON.
- instruments in Safety and double certified construction, are supplied with backlight OFF

Enclosure

Note 1: Refer to the 'Approvals' section for details about the certification on Flameproof & Intrinsically Safe models.
Note 2: For both Ex-ia & Ex-d construction, the protection mode is defined by selecting on the label the correct marking, before the installation of the instrument.

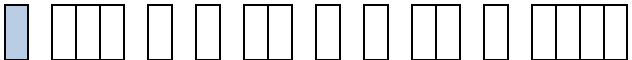
TABLE 1 

ENCLOSURES TYPES	Code
WEATHERPROOF ENCLOSURE	
General Purpose Aluminum housing, IP66, with display.	W
For Aggressive Atmosphere 316 Stainless steel housing, IP66, with display.	A
FLAMEPROOF ENCLOSURES	
Aluminum housing, IP66, with display. (Ex d) // 1/2GD -	H
316 Stainless steel housing, IP66, with display. (Ex d) // 1/2GD - I M2	R
Aluminum housing, IP66, with display. (Ex d) // G	2
316 Stainless steel housing, IP66, with display. (Ex d) // G - I M2	3
INTRINSICALLY SAFE ENCLOSURES	
Aluminum housing, IP66, with display. (Ex ia) // 1/2G	5
316 Stainless steel housing, IP66 with display. (Ex ia) // 1/2G - I M1	4
Aluminum housing, IP66, with display. (Ex ia/Da) // 1/2GD	7
316 Stainless steel housing, IP66 with display. (Ex ia/Da) // 1/2GD - I M1	6
INTRINSICALLY SAFE & FLAMEPROOF ENCLOSURES	
Aluminum housing, IP66, with display. (Ex ia / Ex d according to the installation) // 1/2GD	8
316 Stainless steel housing, IP66 with display. (Ex ia / Ex d according to the installation) // 1/2GD - I M2/M1	9

Model

TABLE 2 

	Code
D21 SMART Pressure Transmitter For applications up to 1000 bar. Overpressure limit up to 1200 bar. Refer Table 5.	D21

Electrical Entry

TABLE 3 

NOTE: Code 0
Available on Enclosure code H,R,2 & 3 as standard.

NOTE: Code 1
Available on Enclosure code W,A,4,5,6 & 7 as standard.

	Code
M20x1.5 thread	0
Packing gland M20x1.5	1
Electrical connection with thread 1/2NPT Female	2

D-Series
Model: D21

Material of Wetted Parts

TABLE 4

NOTE: Code C

Only available with range code E2, F0, F1, F5 & G0 with process connection code D.

	Code
Stainless Steel 316L diaphragm and process connection	A
Hastelloy C276 diaphragm and process connection	B
Gold plated diaphragm and Stainless Steel 316L process connection	C

Range

TABLE 5

Code	Nominal measuring range (FSO)		Minimum set range		Rangeability	Overpressure limit (without hysteresis)	
G0	0...1000 bar	(0...100 MPa)	10 bar	(1 MPa)	100:1	1200 bar	(120 MPa)
F5	0...600 bar	(0...60 MPa)	6 bar	(600 kPa)	100:1	1200 bar	(120 MPa)
F1	0...300 bar**	(0...30 MPa)	3 bar	(300 kPa)	100:1	450 bar	(45 MPa)
F0	0...160 bar**	(0...16 MPa)	1.6 bar	(160 kPa)	100:1	450 bar	(45 MPa)
E2	0...70 bar**	(0...7 MPa)	0.7 bar	(70 kPa)	100:1	140 bar	(14 MPa)
C5	-1...70 bar**	(-0.1...70 MPa)	0.71 bar	(71 kPa)	100:1	140 bar	(14 MPa)
E1	0...25 bar**	(0...2.5 MPa)	0.25 bar	(25 kPa)	100:1	50 bar	(5 MPa)
C4	-1...25 bar**	(-0.1...2.5 MPa)	0.26 bar	(26 kPa)	100:1	50 bar	(5 MPa)
D4	0...7 bar**	(0...0.7 MPa)	0.07 bar	(7 kPa)	100:1	14 bar	(1.4 MPa)
C1	-1...7 bar**	(-100...700 kPa)	0.07 bar	(7 kPa)	114:1	14 bar	(1.4 MPa)
C0	-1...1.5 bar**	(-100...150 kPa)	0.12 bar	(12 kPa)	20:1	4 bar	(400 kPa)
D3	0...2 bar**	(0...200 kPa)	100 mbar	(10 kPa)	20:1	4 bar	(400 kPa)
D1	0...1 bar**	(0...100 kPa)	50 mbar	(5 kPa)	20:1	2 bar	(200 kPa)
C3	-0.5...0.5 bar**	(-50...50 kPa)	50 mbar	(5 kPa)	20:1	2 bar	(200 kPa)
D0	0...0.25 bar**	(0...25 kPa)	25 mbar	(2.5 kPa)	10:1	1 bar	(100 kPa)
A0	-100...100 mbar**	(-10...10 kPa)	20 mbar	(2 kPa)	10:1	1 bar	(100 kPa)
A2	-15...70 mbar */**	(-1.5...7 kPa)	5 mbar	(0.5 kPa)	17:1	0.5 bar	(50 kPa)
A1	-25...25 mbar */***	(-2.5...2.5 kPa)	2 mbar	(0.2 kPa)	25:1	1 bar	(100 kPa)
B1	-7...7 mbar */***	(-0.7...0.7 kPa)	1 mbar	(0.1 kPa)	14:1	1 bar	(100 kPa)
H0	0...1.3 bar abs	(0...130 kPa abs)	100 mbar abs	(10 kPa abs)	13:1	2 bar	(200 kPa)
H1	0...7 bar abs	(0...0.7 MPa abs)	100 mbar abs	(10 kPa abs)	70:1	14 bar	(1.4 MPa)
J0	0...25 bar abs	(0...2.5 MPa abs)	0.25 bar abs	(25 kPa abs)	100:1	50 bar	(5 MPa)
J1	0...70 bar abs	(0...7 MPa abs)	0.7 bar abs	(70 kPa abs)	100:1	140 bar	(14 MPa)
K5	0...300 bar abs	(0...30 MPa abs)	3 bar abs	(300 kPa abs)	100:1	450 bar	(45 MPa)

*Transmitter not available with diaphragm seal; not available in Ex d version.
 **Transmitter available only in version 2
 ***Transmitter available only in version 2; not available with SIL2 (Refer to Table 6)

Version

Combinations of more than one option is available.

NOTE:

Surge arrester is available as standard for Ex d version.

NOTE: Code 2

Available on all ranges except range code H0,H1,J0,J1,G0,F5 & K5 with process connection code B,E, & G.

NOTE: Code 4

Only available with process connection code D.

NOTE: Code Z

Not available with range code A1, A2 & B1 & F5.

NOTE: Code E

Not available with process connection code H,I,J & K.

Refer Table 5 for Range

Refer Table 7 for Process Connection

TABLE 6

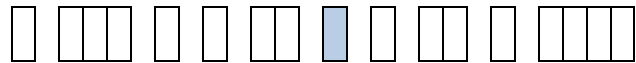

	Code
Applies when no option is required.	0
Surge arrester for Ex ia version	1
Ultra stable version	2
Accuracy $\pm 0.05\%$	3
For oxygen service (sensor filled with Fluorolube fluid)	4
Extended thermal compensation range -40 to $+80^{\circ}\text{C}$	5
Protection class IP67	6
SIL2 - Functional Safety Certificate	Z
Wetted parts suitable for NACE MR-01-75 application.	E
Accuracy $\pm 0.04\%$	M

Process Connection

TABLE 7



NOTE: Codes B & E

Not available with range code G0, F0,F1 & F5.

NOTE: Codes I, J & K

Socket available at extra cost (see fig.1)

M20x1.5 (male) with $\text{\O}4\text{mm}$ hole	A
M20x1.5 (male) with $\text{\O}12\text{mm}$ hole	B
G1/2" (male) with $\text{\O}4\text{mm}$ hole	D
G1/2" (male) with $\text{\O}12\text{mm}$ hole	E
1/2" NPT Male (Pressure Limits: max. 690 bar) & G1/4" Female (Pressure Limits: max. 1000 bar)	G
1/2" NPT Female via adaptor (Pressure limits: max 690 bar)	H
M30x2 with flush diaphragm (Pressure limits: min 0.1 bar / max 70 bar)	I
G1" with flush diaphragm (Pressure limits: min 0.1 bar / max 70 bar)	J
G1/2" with flush diaphragm (Pressure limits: min 2.5 bar / max 300 bar)	K

Options

Combination of more than one option is available.
(i.e. Code 13 - combination of code 10 & 30)

TABLE 8

	Code
Applies when no option is required	00
Mounting bracket for 2" pipe, material stainless steel	10
Stainless Steel rating label riveted to the housing	20
Stainless Steel tag plate mounted on wire	30
Mounting bracket for 2" pipe, material zinced steel	40

Output Signal

Note: Please refer to APPROVALS page for marking & protection.

TABLE 9

	Code
4 to 20mA (Weatherproof or Hazardous Area with ATEX marking)	0
4 to 20mA (Hazardous Area with IECEx marking)	6
4 to 20mA (Hazardous Area with UKEx marking)	7

Special Engineering

Last 4 digits of model code only used when special engineering is required.

TABLE 10

	Code
Please consult Delta Mobrey sales engineering for special requirements	TBA

Application & Construction

The SMART Pressure Transmitters are suitable for the measurement of pressure, under pressure, and absolute pressure of gases, vapours and liquids. The active sensing element is a piezoresistive silicon sensor separated from the medium by a diaphragm and by a specifically selected type of manometric liquid. The casing is made of cast aluminium alloy with epoxy coating or 316 stainless steel with degree of protection IP66/67. The design of the casing enables the use of a local display, rotation of the display, rotation of the casing by 0-340° relative to the sensor, and a choice of cable direction.

The communication standard for data interchange with the transmitter is the Hart protocol.

Communication with the transmitter is carried out with:

- a D-COMM communicator,
- some other Hart type communicators, (*)
- a PC using a HART/USB/Bluetooth converter and D-Soft configuration software

(*) .eddl file available at www.delta-mobrey.com

The data interchange with the transmitter enables the users to:

- Identify the transmitter;
- Configure the output parameters:
 - measurement units and the values of the start points and end points at the measurement range;
 - damping time constant;
 - conversion characteristic (inversion, user's non-linear characteristic);
- Read the currently measured pressure value of the output current and the percentage output control level;
- Force an output current with a set value;
- Calibrate the transmitter in relation to a model pressure

Installation

The transmitter can be installed directly on the installation. A universal mounting bracket is provided to transmitter fitting on 2" pipe. When the pressure of steam or other hot media is measured, a siphon or impulse line should be used. The needle valve placed upstream the transmitter simplifies installation process and enables the zero point adjustment or the transmitter replacement. When the special process connections are required for the measurement of levels and pressures (e.g. at food and chemical industries), the transmitter is provided with a diaphragm seal. The transmitter's electrical connections should be performed with twisted cable. The place for the communicator should be assigned before the communicator installation.

Technical Data

Metrological Parameters

Accuracy	$\leq \pm 0.075\%$ of the calibrated range ($\leq \pm 0.1\%$ for range B1) Special version: $\leq \pm 0.05\%$ of the calibrated range ($\leq 0.04\%$ on request)	Thermal compensation range	-25...80°C -40 ...80°C – special version
Long-term stability (for the nominal measuring range) Version 2 (range F1,F0,E2,C5,E1,C4,D4,C1,C0,D3,D1,C3,D0) :	\leq accuracy for 3 years or $\leq 2 \times$ accuracy for 5 year \leq accuracy for 6 years or $\leq 2 \times$ accuracy for 5 years	Response time	16...480ms(programmable) Ex d version: 150ms
Thermal error	$< \pm 0.05\%$ (FSO) / 10°C (0.1% for ranges A0, A1, A2, B1) max. $\pm 0.25\%$ (FSO) in the whole compensation range	Additional electronic damping	0...60 s
		Error due to supply voltage changes	0.002% (FSO) / V
		Load resistance (for standard version)	$R [\Omega] \leq \frac{U_{sup} [V] - 10V}{}$

Electrical parameters

Power supply:	10...55 VDC / Exia: 10.5...30 VDC / Exd: 10.5...45 VDC SIL2: 15...45 VDC / SIL2 Exia: 16...28 VDC	
Output signal	4...20 mA, two wire transmission Special Version: 0...20 / 0...5 / 4...20 [mA] Hart Version (SIL is only 5) Ver. 5 as standard (Ver.7 on request)	Resistance required for communication
		240Ω 0.0225A min.

Materials

Wetted parts and Diaphragms	316LSS, Hastelloy C 276, Au
Casing	Aluminium, 316SS

Operating conditions

Operating temperature range (ambient temp.)	-40...85°C Ex i version -40...80°C Ex d version -40...75°C
--	--

Process medium temperature range

-40...120 °C
 over 120 °C –measurement with the use of impulse line or diaphragm seals

CAUTION: the medium must not be allowed to freeze in the impulse line or close to the process connection of the transmitter

Accuracy depending on the set range

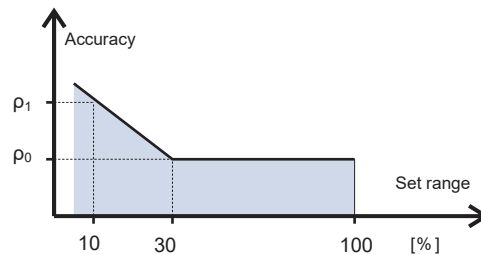

ρ_0 – error for range 30...100% FSO
 ρ_1 – error for range 10% FSO
 $\rho_1 = 2 \times \rho_0$

Numerical error values are given in the technical data under metrological parameters

Electrical diagrams

Electrical diagrams for transmitters with HART protocol

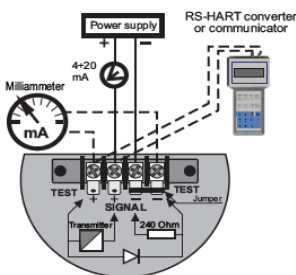

Version with output signal: 4-20mA

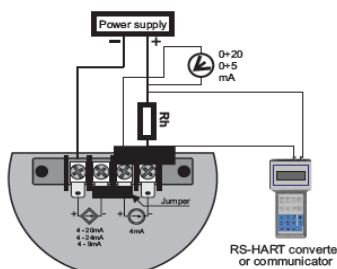

Version with output signal: 0-5mA or 0-20mA

D-Series

Model: D21

Approvals

GLOBAL CERTIFICATION

IECEX Certified - output signal code 6 (see table 9)

INTRINSICALLY SAFE:



Certificate No.: **IECEX FTZU 15.0027X**
IEC 60079-0, IEC 60079-11,

For Zone 0/1 models

Enclosure code 7 (refer Table 1)

Ex ia IIC T4/T5 Ga/Gb
Ex ia IIIC T105°C Da (version with PTFE shielded cable)

Enclosure code 8 (refer Table 1)

Ex ia I Ma
Ex ia IIC T4/T5 Ga/Gb
Ex ia IIB T4/T5 Ga/Gb (version with PTFE shielded cable)

Certificate No.: **KDB19ATEX006X**
EN IEC 60079-0, EN 60079-11, EN 60079-26, EN 50303

For Zone 0/1,20 models

Enclosure code 5 SIL version (refer Table 1)

Ex ia IIC T4/T5 Ga/Gb

Enclosure code 4 SIL version (refer Table 1)

Ex ia I Ma
Ex ia IIC T4/T5 Ga/Gb

Enclosure code 7 (refer Table 1)

Ex ia IIC T4/T5 Ga/Gb
Ex ia IIIC T105°C Da

Enclosure code 8 (refer Table 1)

Ex ia I Ma
Ex ia IIC T4/T5 Ga/Gb
Ex ia IIIC T105°C Da

FLAMEPROOF:



Certificate No.: **IECEX KDB 19.006X**
IEC 60079-0, IEC 60079-1, IEC 60079-11, IEC 60079-26, IEC 60079-31

For Zone 0/1, 20/21 models

Enclosure code H (refer Table 1)

Ex ia/db IIC T6/T5 Ga/Gb
Ex ia/tb IIIC T105°C Da/Db

Enclosure code R (refer Table 1)

Ex db ia I Mb
Ex ia/db IIC T6/T5 Ga/Gb
Ex ia/tb IIIC T105°C Da/Db

For Zone 1, 21 models

Enclosure code 2 (refer Table 1)

Ex ia/db IIC T6/T5 Gb
Ex ia/tb IIIC T105°C Db

Enclosure code 3 (refer Table 1)

Ex db ia I Mb
Ex ia/db IIC T6/T5 Gb
Ex ia/tb IIIC T105°C Db

INTRINSICALLY SAFE & FLAMEPROOF (*):

(*) According to the selection on the label



Certificate No.: **IECEX KDB 19.006X**
IEC 60079-0, IEC 60079-1, IEC 60079-11, IEC 60079-26, IEC 60079-31

For Zone 0/1, 20/21 or 0/1, 20 models

Enclosure code 8 (refer Table 1)

Ex ia/db IIC T6/T5 Ga/Gb
Ex ia/tb IIIC T105°C Da/Db
Or

Enclosure code 9 (refer Table 1)

M2 Ex db ia I Mb
Ex ia/db IIC T6/T5 Ga/Gb
Ex ia/tb IIIC T105°C Da/Db
Or

Ex ia IIC T5/T4 Ga/Gb
Ex ia IIIC T105°C Da

Ex ia I Ma
Ex ia IIC T5/T4 Ga/Gb
Ex ia IIIC T105°C Da



Functional Safety Certified

Meets the requirements of IEC 61508: 2010 part 1-7 ; IEC 61511-1:2016+IEC 61511-1:2016/AMD1:2017
IEC 62061:2005 + IEC 62061:2005/AMD1:2012 + IEC 62061:2005/AMD2:2015 for use in safety related systems.
Systematic capability: SC 3;
SIL2 @ HFT 0; Route 1_H
SIL3 @ HFT 1; Route 1_H
Certificate No. UDT-CERT No.1005/CW/001

Approvals

EUROPEAN DIRECTIVE)

ATEX Directive 2014/34/EU - output signal code O (see table 9)

INTRINSICALLY SAFE:



Certificate No.: **FTZU 19ATEX0111X**
EN IEC 60079-0, EN 60079-11, EN 50303

For Zone 0/1 models

Enclosure code 5 (refer Table 1)

II 1/2G Ex ia IIC T4/T5 Ga/Gb
II 1D Ex ia IIIC T105°C Da (version with PTFE shielded cable)

Enclosure code 4 (refer Table 1)

I M1 Ex ia I Ma
II 1/2G Ex ia IIC T4/T5 Ga/Gb
II 1D Ex ia IIIC T105°C Da (version with PTFE shielded cable)



Certificate No.: **KDB19ATEX0045X**
EN IEC 60079-0, EN 60079-11, EN 60079-26, EN 50303

For Zone 0/1,20 models

Enclosure code 5 SIL version (refer Table 1)

II 1/2G Ex ia IIC T4/T5 Ga/Gb

Enclosure code 4 SIL version (refer Table 1)

I M1 Ex ia I Ma
II 1/2G Ex ia IIC T4/T5 Ga/Gb

Enclosure code 7 (refer Table 1)

II 1/2G Ex ia IIC T4/T5 Ga/Gb
II 1D Ex ia IIIC T105°C Da

Enclosure code 8 (refer Table 1)

I M1 Ex ia I Ma
II 1/2G Ex ia IIC T4/T5 Ga/Gb
II 1D Ex ia IIIC T105°C Da

FLAMEPROOF:



Certificate No.: **KDB19ATEX0045X**
EN IEC 60079-0, EN 60079-1, EN 60079-11, EN 60079-26, EN 60079-31, EN50303

For Zone 0/1, 20/21 models

Enclosure code H (refer Table 1)

II 1/2G Ex ia/db IIC T6/T5 Ga/Gb
II 1/2D Ex ia/tb IIIC T105°C Da/Db

Enclosure code R (refer Table 1)

I M2 Ex db ia I Mb
II 1/2G Ex ia/db IIC T6/T5 Ga/Gb
II 1/2D Ex ia/tb IIIC T105°C Da/Db



For Zone 1, 21 models

Enclosure code 2 (refer Table 1)

II 2G Ex ia/db IIC T6/T5 Gb
II 2D Ex ia/tb IIIC T105°C Db

Enclosure code 3 (refer Table 1)

I M2 Ex db ia I Mb
II 2G Ex ia/db IIC T6/T5 Gb
II 2D Ex ia/tb IIIC T105°C Db

INTRINSICALLY SAFE & FLAMEPROOF (*):

(*) According to the selection on the label



Certificate No.: **KDB19ATEX0045X**
EN IEC 60079-0, EN 60079-1, EN 60079-11, EN 60079-26, EN 60079-31, EN50303

For Zone 0/1, 20/21 or 0/1, 20 models

Enclosure code 8 (refer Table 1)

II 1/2G Ex ia/db IIC T6/T5 Ga/Gb
II 1/2D Ex ia/tb IIIC T105°C Da/Db
or

Enclosure code 9 (refer Table 1)

M2 Ex db ia I Mb
II 1/2G Ex ia/db IIC T6/T5 Ga/Gb
II 1/2D Ex ia/tb IIIC T105°C Da/Db
or
I M1 Ex ia I Ma
II 1/2G Ex ia IIC T5/T4 Ga/Gb
II 1D Ex ia IIIC T105°C Da



II 1/2G Ex ia IIC T5/T4 Ga/Gb
II 1D Ex ia IIIC T105°C Da

EMC Directive 2014/30/EU

Conformity assessment procedure: module A
The following standards were applied: EN 61326-1:2013; EN61326-2-3:2013



2014/68/EU Pressure Equipment Directive

For Nameplate Parameter **PS>200 bar**: The transmitters in PED version according to Module A of Directive 201/68/EU have specified on the nameplate parameters PS>200bar, P(range),.....T(amb.).....
For Nameplate Parameter **PS< 200bar**, P(range),.....T(amb.)..... are manufactured on the basis of Article 4, Clause 3 of Directive 2014/68/EU in accordance with the sound engineering practice

Restriction of hazardous substances (RoHS 2) 2011/65/EU

Compliant to RoHS. The following standard was applied: EN IEC 63000:201

Approvals

UK REGULATIONS

Equipment and Protective Systems Intended for use in Potentially Explosive Atmospheres Regulations 2016

Output signal code 7 (see table 9)

INTRINSICALLY SAFE:



Certificate No.: **ExVeritas 22UKEX1416X**
EN IEC 60079-0, EN 60079-11, EN60079-26, EN 50303

For Zone 0/1, 20 models



Enclosure code 5 SIL version (refer Table 1)
II 1/2G Ex ia IIC T4/T5 Ga/Gb

Enclosure code 7 (refer Table 1)
II 1/2G Ex ia IIC T4/T5 Ga/Gb
II 1D Ex ia IIIC T105°C Da

Enclosure code 4 SIL version (refer Table 1)

I M1 Ex ia I Ma
II 1/2G Ex ia IIC T4/T5 Ga/Gb

Enclosure code 8 (refer Table 1)
I M1 Ex ia I Ma
II 1/2G Ex ia IIC T4/T5 Ga/Gb
II 1D Ex ia IIIC T105°C Da

FLAMEPROOF:



Certificate No.: **22UKEX1416X**
EN IEC 60079-0, EN 60079-1, EN 60079-11, EN 60079-26, EN 60079-31, EN50303

For Zone 0/1, 20/21 models



Enclosure code H (refer Table 1)
II 1/2G Ex ia/db IIC T6/T5 Ga/Gb
II 1/2D Ex ia/tb IIIC T105°C Da/Db

For Zone 1, 21 models

Enclosure code 2 (refer Table 1)
II 2G Ex ia/db IIC T6/T5 Gb
II 2D Ex ia/tb IIIC T105°C Db

Enclosure code R (refer Table 1)
I M2 Ex db ia I Mb
II 1/2G Ex ia/db IIC T6/T5 Ga/Gb
II 1/2D Ex ia/tb IIIC T105°C Da/Db

Enclosure code 3 (refer Table 1)
I M2 Ex db ia I Mb
II 2G Ex ia/db IIC T6/T5 Gb
II 2D Ex ia/tb IIIC T105°C Db

INTRINSICALLY SAFE & FLAMEPROOF (*):

(*) According to the selection on the label



Certificate No.: **22UKEX1416X**
EN IEC 60079-0, EN 60079-1, EN 60079-11, EN 60079-26, EN 60079-31, EN50303

For Zone 0/1, 20/21 or 0/1, 20 models



Enclosure code 2 (refer Table 1)
II 1/2G Ex ia/db IIC T6/T5 Ga/Gb
II 1/2D Ex ia/tb IIIC T105°C Da/Db
or

II 1/2G Ex ia IIC T5/T4 Ga/Gb
II 1D Ex ia IIIC T105°C Da

Enclosure code 3 (refer Table 1)
M2 Ex db ia I Mb
II 1/2G Ex ia/db IIC T6/T5 Ga/Gb
II 1/2D Ex ia/tb IIIC T105°C Da/Db
or
I M1 Ex ia I Ma
II 1/2G Ex ia IIC T5/T4 Ga/Gb
II 1D Ex ia IIIC T105°C Da

Dimensions

Figure 1
(All dimensions in mm)

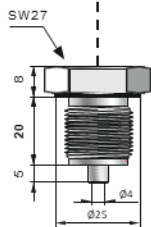
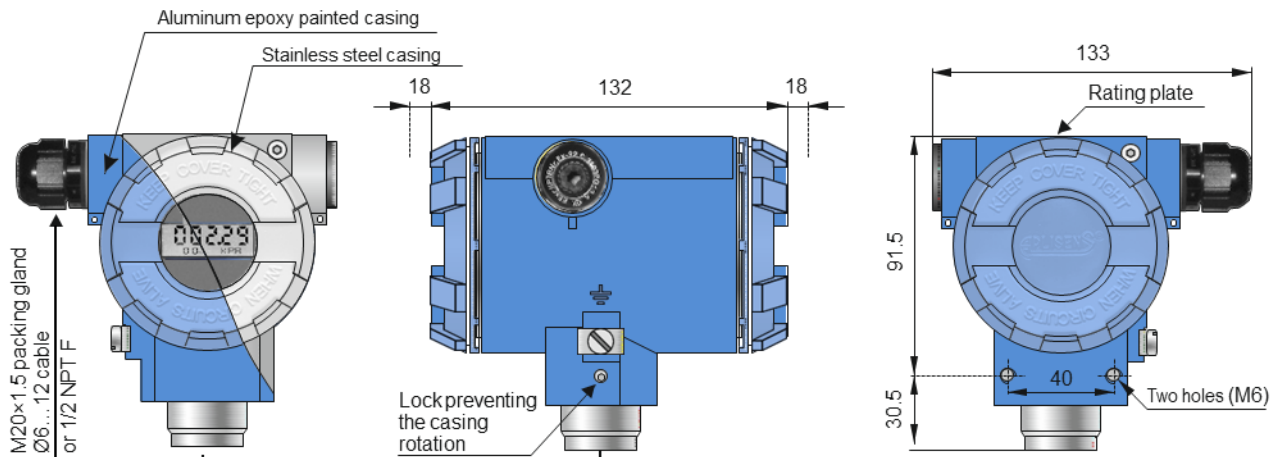

Conn. D type
G1/2", Ø4 hole
Conn. A type
M20x1.5, Ø4 type

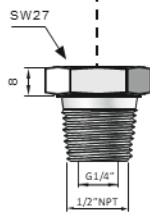

Conn. D type
1/2" NPT male +
internal thread G1/4"

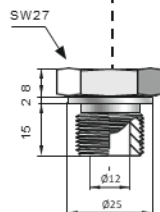

Conn. E type
G1/2", Ø12 hole
Conn. B type
M20x1.5, Ø12 type

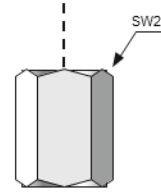

Conn. H type
internal thread
1/2-14NPT

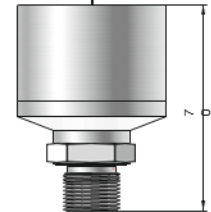

Conn. E type
Conn. B type
1/2" NPT Male
for version code 2

G

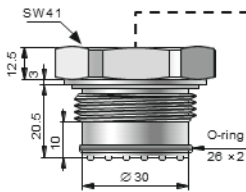

Conn. J type
G1" with flush diaphragm

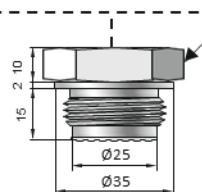

Conn. I type
M30x2 with flush diaphragm

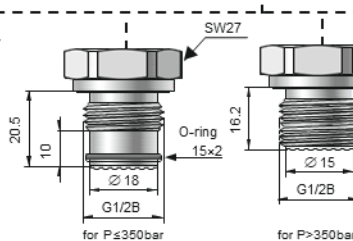

Conn. K type
G1/2" with flush diaphragm

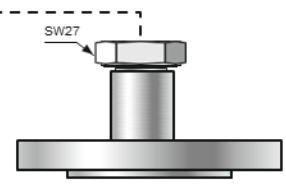

**Version with direct or remote
diaphragm seal**

Socket for flush diaphragm process connection (supplied on request)

Part 37003867 (1"GM-"J") - Part 37003868 (M30x1.5-"I") - Part. 37003869 (1/2" GM-"K")

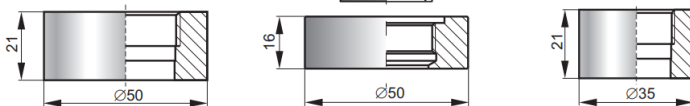

WEIGHT

Model	Weight
D21 / Connection G1/2"	0.46 kg

Weight may varies with different process connections.

In the interest of development and improvement Delta Mobrey Ltd, reserves the right to amend, without notice, details contained in this publication. No legal liability will be accepted by Delta Mobrey Ltd for any errors, omissions or amendments.

Delta Mobrey Limited
Hudson House, Albany Park Camberley Surrey, GU16 7PL, UK.
T+44 (0)1252 729140 F+44 (0)1252 729168 E sales@delta-mobrey.com W www.delta-mobrey.com

D-Series
Model: D21

