

Installation, Operation & Maintenance Instructions

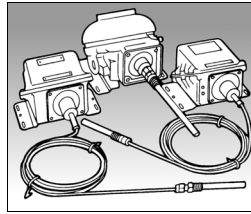

Performance Series

Models 721, 722, 723, 731, 732, 733, 734, 781
(Vapour Pressure Temperature Switches)
Models 771, 772, 773, 774
(Gas Filled Temperature Switches)



General

The unit is manufactured, checked and supplied in accordance with our published specification, and when installed and used in normal or prescribed applications, with the lid in place and within the parameters set for mechanical and electrical performance, will not cause danger or hazard to life or limb.



THE USERS ATTENTION IS DRAWN TO THE FACT THAT, WHEN THE UNIT IS 'LIVE' WITH RESPECT TO ELECTRICAL OR PRESSURE SUPPLIES, A HAZARD MAY EXIST IF THE UNIT IS OPENED OR DISMANTLED.



UNITS MUST BE SELECTED AND INSTALLED BY SUITABLY TRAINED AND QUALIFIED PERSONNEL IN ACCORDANCE WITH APPROPRIATE CODES OF PRACTICE SO THAT THE POSSIBILITY OF FAILURE RESULTING IN INJURY OR DAMAGE CAUSED BY MISUSE OR MISAPPLICATION IS AVOIDED.



ATEX

PURCHASER SHOULD ENSURE THE EQUIPMENT IS SUITABLE FOR USE IN THE APPLICATION WITH AGGRESSIVE SUBSTANCE.

Operating principles

Temperature Switch models 721, 722, 723, 731, 732, 733, 734, 781, 771, 772, 773, 774 are bellows operated switches.

These bellows generate a force proportional to the applied pressure and are balanced by a user adjustable control spring. When the force exceeds that created by the control spring, the bellow moves causing a beam to actuate a snap-acting micro-switch(s).

The applied pressure comes from the expansion of a vapour /gas enclosed in either a rigid or semi-rigid thermal system.

CERTIFICATIONS

ATEX & IECEx

For Zone 1 (Enclosure code H/K, see Table 1 of TDS)



II 2 GD Ex db IIC T4 Gb (Tamb -60°C to +80°C)
Ex tb IIIC T135°C Db IP66



II 2 GD Ex db IIC T6 Gb (Tamb -60°C to +40°C)
Ex tb IIIC T85°C Db IP66

For Zone 2 (Enclosure code N/O, see Table 1 of TDS)



II 3 GD Ex tD A22 T23°C
EEx nC II T6 (Tamb -20°C to +60°C)

INSTALLATION

Mounting (All models)

The instruments are designed to be mounted vertically with the thermowell connection underneath. Select the mounting point so as to avoid excessive shock, vibration or temperature fluctuation. Instruments should be mounted to avoid excessive heat transfer from the process lines or adjacent plant. To avoid undue stresses being imparted to the instrument when wall/panel mounted, it is recommended that a short length of flexible line be installed between the instrument and process line.



CHECK THE CONNECTION THREAD SIZE AND SPECIFICATION ON THE UNIT TO AVOID MIS-MATCHING WITH THE PROCESS CONNECTION ADAPTOR. SEE DIGIT 11 OF PRODUCT CODE.

Mounting (Rigid Stem)

Assemble the unit via a thermowell, using the spanner facility provided and ensuring that:

- a) the sensing bulb is fully immersed in the process temperature
- b) the sensing bulb does not bottom out in the thermowell which could cause damage

Mounting (Capillary system)

Mount the sensing bulb so that the capillary end is above the bulb and the bulb is level with, or no more than 250mm below the base of the instrument. The stem is fitted with a sliding compression gland to accommodate different thermowells.

Installation of electrical adaptors and cable glands to the electrical entry

Either one or two electrical entries can be provided. The standard entry is a single ISO M20 x 1.5 thread. Other non-ISO and tapered threads will have their size and type stamped on the enclosure next to the entry.



ATEX

TAKE CARE TO SELECT AND INSTALL ADAPTORS THAT DO NOT REDUCE THE ENCLOSURE'S DEGREE OF PROTECTION WHEN IN USE IN ZONE 1 HAZARDOUS AREAS.



ATEX

UNUSED ENTRIES MUST BE FITTED WITH SUITABLY CERTIFIED FLAME-PROOF STOPPING PLUGS.



ATEX

IT IS A SAFETY REQUIREMENT THAT AT LEAST 5 FULL THREADS ARE ENGAGED BETWEEN THE ADAPTER, CABLE GLAND OR STOPPING PLUG, AND THE ELECTRICAL ENTRY WHEN THE UNIT IS IN OPERATION. NEVER OPERATE THE UNIT UNLESS THIS CONDITION IS MET.

Alternative electrical entry threads

One or two electrical entries can be supplied with the following optional thread types:

- ISO to BS 3643 (1981) medium fit 6H up to M25 x 1.5
- DIN 40430 (1971) up to Pg21.
- USAS B2.1 (1968) gauging to clauses 36 & 37 up to 3/4" NPT.
- BS conduit to BS31 (1940) table 'A' up to 1"
- BSP to BS21(1985) standard threads only as clause 5.4 gauging to clause 5.2 system 'A' up to Rp3/4 (medium fit or better).

Wiring



DISCONNECT ALL SUPPLY CIRCUITS BEFORE WIRING



WIRE IN ACCORDANCE WITH LOCAL AND NATIONAL CODES. USE CABLES NO LARGER THAN 2.5 MM² (14 AWG)



DO NOT EXCEED ELECTRICAL RATINGS STATED IN LITERATURE AND ON NAMEPLATES.

The three switch terminals are clearly marked "NORMALLY CLOSED", "NORMALLY OPEN" and "COMMON". The following diagram can be used as a guide for wiring.

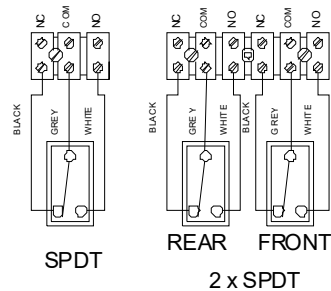

NC = NORMALLY CLOSED
COM = COMMON
NO = NORMALLY OPEN

Fig. 1

Insert bare wires fully into the terminal block and tighten securely. Keep wiring tails to a minimum and check that wires do not interfere with the operating mechanism. Use the earthing / grounding points provided.

End of line resistors

Some products may be supplied to order fitted with end of line resistors. Resistors in use may generate a heat source. The type, quantity, configuration, fitment method and allowable electrical loads are limited by the scope of the certification.



ATEX

NEVER FIT END OF LINE RESISTORS OR MODIFY WITHOUT REFERENCE TO DELTA MOBREY

Replacing cover / lid on Flameproof enclosures



BEFORE CLOSING THE LID:

- ENSURE WIRE IS CLEAR OF ALL MOVING PARTS.
- ENSURE THAT WIRES DO NOT TOUCH THE LID AS IT IS CLOSED.

Thread, seal and contact surfaces may be lightly lubricated using a non-setting non-corrosive grease compatible with the lid seal.



ATEX

DO NOT USE COPPER BEARING GREASE ON ALUMINIUM.

Before connecting to electrical power, screw on cover/lid hand tight making sure that mating surfaces of the lid and enclosure are in contact. Use the locking screw provided to prevent casual and unauthorised removal of the cover/lid.



ATEX

IT IS A SAFETY REQUIREMENT THAT AT LEAST 5 FULL THREADS ARE ENGAGED BETWEEN THE COVER / LID AND THE ENCLOSURE WHEN THE UNIT IS IN OPERATION. NEVER OPERATE THE UNIT UNLESS THIS CONDITION IS MET.

OPERATION



ATEX

THIS UNIT CONTAINS POTENTIALLY SPARKING CONTACTS. DO NOT REMOVE THE COVER / LID WHILE ELECTRICAL POWER IS CONNECTED TO THE SWITCH AND / OR WHEN A FLAMMABLE GAS ATMOSPHERE IS PRESENT.

Adjustments

Temperature Switches are supplied calibrated at the midpoint of their range and to a falling temperature unless otherwise specified.

Set point adjustments (Models 721, 722, 723, 731, 732, 733, 771, 772, 773)

(See fig. 2):

1. Isolate the instrument from process and power.
2. Remove the lid to allow access
3. Loosen the M3 hexagon head locking screw.
4. Rotate the 20 mm A/F hexagon head adjuster knob to move the indicator along the calibrated scale. Rotate clockwise to increase the set point and counter clockwise to decrease the set point.
5. Retighten the locking screw taking care not to overtighten.
6. Replace the instrument lid (See maintenance).

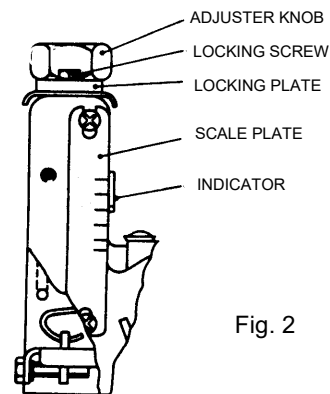

Fig. 2

Set point adjustments (Models 781, 734, 774) (See fig. 3):

The models 781, 734, 774 provide 2 microswitches which can be set independently against individual scales using a special dual beam mechanism. This fulfils the need for HI LO switching, adjust as follows:

1. Isolate the instrument from process and power.
2. Remove the lid to allow access
3. Loosen the rear M3 hexagon head locking screw.
4. Rotate the rear adjuster screw to move the indicator on the right hand (LO) calibrated scale. Rotate clockwise to increase the set point and counter clockwise to decrease the set point.
5. Retighten the locking screw.
6. Loosen the front hexagon head locking screw.
7. Rotate the front adjuster screw to move the indicator on the left hand (HI) calibrated scale. Rotate clockwise to increase the set point and counter clockwise to decrease the set point.
8. Tighten the locking screw.
9. Replace the instrument lid (see maintenance)

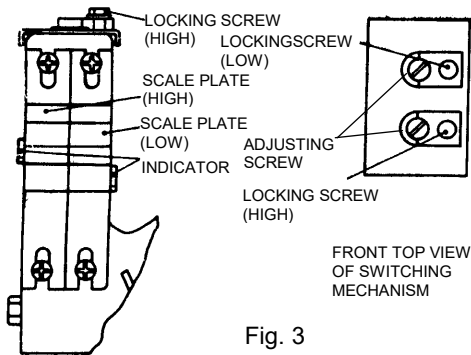

Fig. 3

Switching differential adjustment (Model 722, 732, 772 only) (See fig. 4):

1. Isolate the instrument from process and power.
2. Remove the lid to allow access
3. Rotate the knurled plastic wheel on the microswitch to adjust the switching differential. Rotate clockwise to increase differential and counter-clockwise to reduce differential.
4. Replace instrument lid (See maintenance).

Note: Rotating the knurled plastic wheel will alter the operating value on rising pressure only.

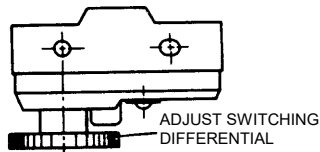

Fig. 4

Switching differential adjustment (Model 723, 733, 773 only) (See fig. 5):

1. Isolate the instrument from process and power.
2. Remove the lid to allow access
3. Rotate the secondary adjuster screw to move the secondary indicator along the "arrow" scale. Rotate clockwise to increase the differential and counter clockwise to decrease the differential.
4. Replace instrument lid (See maintenance).

Note: Rotating the secondary adjuster knob (screw) will alter the operating value on rising pressure only.

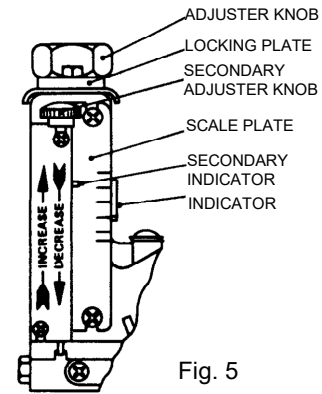

Fig. 5

Note: For accurate setting, a suitable temperature gauge should be used in conjunction with the above procedure. Do not attempt to set the switch outside the scale limits. Though the unit may be set anywhere within its operation range, for optimum performance, it is good practice to have a set point value between 25% and 75% of span.

MAINTENANCE

Inspections should be carried out at quarterly to yearly intervals depending upon operating conditions. Isolate the unit from process and power and remove the lid. Check all terminals for tightness. Check that cable tails are not fouled or chafed. Check for internal condensation. Check that the gasket is seated properly in the lid recess and is not worn. Keep the enclosure and lid clear of dust build up. It is recommended that instruments used to provide an alarm are operated periodically to ensure they are functioning correctly. If further maintenance is required seek advice from DELTA MOBREY before attempting repair or replacement of parts.

SPECIAL CONDITIONS FOR SAFE USE

This note relates to flameproof models with ATEX certification number BAS01ATEX2426X.

The apparatus has a specified flamepath with a diametrical clearance of 0.1 mm maximum associated with the push rod and bush assembly passing through the enclosure wall, which is less than the maximum permitted by the standard EN 60079-1 to which the certification is issued. The user shall ensure that, in service, the diametrical clearance of this flamepath does not exceed 0.1 mm.

NOTE: Under normal operating conditions where the process is not continually cycling above and below the set point, the wear will be minimal. To examine for wear remove the pressure sensor from the bottom of the enclosure and examine the rod and bush assembly for obvious wear. Do not attempt to remove the assembly and if in doubt seek assistance from Delta Mobrey.



ONLY OPERATION, MAINTENANCE OR REPAIR PROCEDURES. EITHER CONTAINED HEREIN OR APPROVED BY DELTA MOBREY MAY BE USED, TO AVOID RENDERING THE EQUIPMENT UNSAFE IN OPERATION AND/OR NULLIFYING THE CERTIFICATION. NO MODIFICATIONS ARE PERMITTED.

DIMENSIONS

Models 721, 722, 723, 731, 732, 733, 734, 781, 771, 772, 773, 774

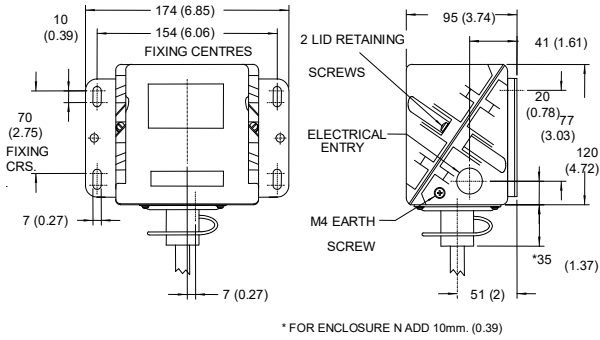

ENCLOSURE W, N

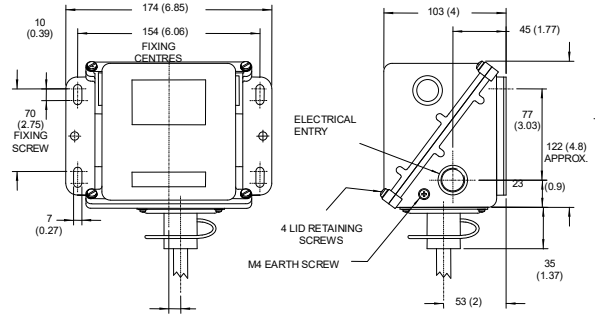

ENCLOSURE A

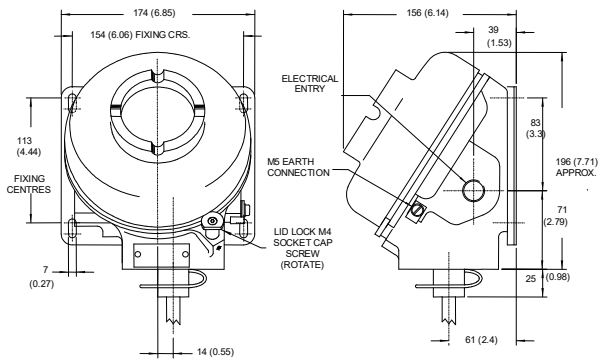

ENCLOSURES H, K, M

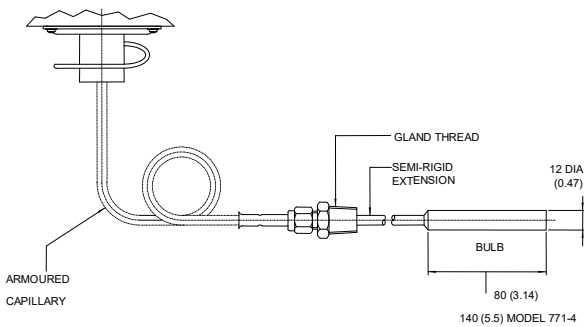

SENSING ELEMENT — MODELS 721, 722, 723, 771, 772, 773 774, 781

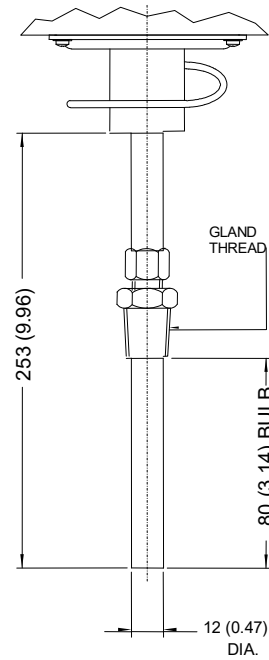

SENSING ELEMENT — MODELS 731, 732, 733, 734