

Installation, Operation & Maintenance Instructions



Industrial Series

Models S21, S22, S24 (Pressure Switches)

Models S31, S34 (Differential Pressure Switches)

Model S71 (Temperature Switches)

GENERAL

The unit is manufactured, checked and supplied in accordance with our published specification, and when installed and used in normal or prescribed applications, with the lid in place and within the parameters set for mechanical and electrical performance, will not cause danger or hazard to life or limb.



THE USERS ATTENTION IS DRAWN TO THE FACT THAT, WHEN THE UNIT IS 'LIVE' WITH RESPECT TO ELECTRICAL OR PRESSURE SUPPLIES, A HAZARD MAY EXIST IF THE UNIT IS OPENED OR DISMANTLED.



UNITS MUST BE SELECTED AND INSTALLED BY SUITABLY TRAINED AND QUALIFIED PERSONNEL IN ACCORDANCE WITH APPROPRIATE CODES OF PRACTICE SO THAT THE POSSIBILITY OF FAILURE RESULTING IN INJURY OR DAMAGE CAUSED BY MISUSE OR MISAPPLICATION IS AVOIDED.

OPERATING PRINCIPLES

Pressure Switch models S21, S22, S24 and Differential Pressure Switch models S31, S34 are diaphragm operated switches.

These diaphragms generate a force proportional to the applied pressure and are balanced by a user adjustable control spring. When the force exceeds that created by the control spring, the diaphragm moves causing a push rod to actuate a snap-acting micro-switch.

Temperature model S71 works in the same way as the Pressure models with the exception that the applied pressure comes from the expansion of a vapour enclosed in either a rigid stem or semi-rigid thermal system.

CERTIFICATIONS

ATEX

Intrinsically safe Models

For Zone 0 models (Enclosure code 4/5, see Table 1 of TDS)

II 1 G Ex ia IIC T6 Ga (Tamb = -25°C to +60°C)
T5 Ga (Tamb = -60°C to +80°C)



Flameproof Models

For Zone 0/1 models (Enclosure code 2/3, see Table 1 of TDS)

With Fluorosilicone O-ring

II 1/2 GD Ex d IIC T6 Ga/Gb (Tamb = -60°C to 65°C)
Ex ta/tb IIIC T85°C Da/Db



or

II 1/2 GD Ex d IIC T5 Ga/Gb (Tamb = -60°C to 80°C)
Ex ta/tb IIIC T100°C Da/Db



or

With Nitrile O-ring

II 1/2 GD Ex d IIC T6 Ga/Gb (Tamb = -30°C to 65°C)
Ex ta/tb IIIC T85°C Da/Db



or

II 1/2 GD Ex d IIC T5 Ga/Gb (Tamb = -30°C to 80°C)
Ex ta/tb IIIC T100°C Da/Db



For Zone 1 models (Enclosure code H/R, see Table 1 of TDS)

With Fluorosilicone O-ring

II 2 GD Ex d IIC T6 Gb (Tamb = -60°C to 65°C)
Ex tb IIIC T85°C Db



or

II 2 GD Ex d IIC T5 Gb (Tamb = -60°C to



80°C)

Ex tb IIIC T100°C Db

With Nitrile O-ring

II 2 GD Ex d IIC T6 Gb (Tamb = -30°C to 65°C)
Ex tb IIIC T85°C Db



or

II 2 GD Ex d IIC T5 Gb (Tamb = -30°C to 80°C)
Ex tb IIIC T100°C Db



cCSAus

For use in Class 1, Group C/D, Class II, Groups E/F/G, Div. 1 & 2 (Enclosure code T/U, see Table 1 of TDS)

INSTALLATION

Mounting (All models)

The instruments are designed to be mounted vertically with the process connection underneath. However, mounting up to 45° from the vertical in any plane is acceptable, although a small calibration shift may occur. They can be mounted either direct to process, or to a wall or panel using the mounting holes provided. Select the mounting point so as to avoid excessive shock, vibration or temperature fluctuation. External sources of heating or cooling should be taken into consideration during installation. To avoid undue stresses being imparted to the instrument when wall/panel mounted, it is recommended that a short length of flexible line be installed between the instrument and process line. If sudden changes of pressure (pulsations) are likely then we recommend that snubbers are fitted between the process line and instrument.



ALWAYS HOLD A WRENCH ON THE PRESSURE ENTRY HEX WHEN MAKING PRESSURE CONNECTION TO THE SWITCH. DO NOT TIGHTEN BY TURNING THE ENCLOSURE.



CHECK THE CONNECTION THREAD SIZE AND SPECIFICATION ON THE UNIT TO AVOID MIS-MATCHING WITH THE PROCESS CONNECTION ADAPTOR. SEE DIGIT 11 OF PRODUCT CODE.

Mounting (S71 - Rigid Stem)

Assemble the unit via a thermowell, using the spanner facility provided and ensuring that:

- a) the sensing bulb is fully immersed in the process temperature
- b) the sensing bulb does not bottom out in the thermowell which could cause damage

Mounting (S71 - Capillary system)

Mount the sensing bulb so that the capillary end is above the bulb and the bulb is level with, or no more than 250mm below the base of the instrument. The stem is fitted with a sliding compression gland to accommodate different thermowells.

Installation of electrical adaptors and cable glands to the electrical entry

Either one or two electrical entries can be provided. The standard entry is a single ISO M20 x 1.5 thread. Other non-ISO and tapered threads will have their size and type stamped on the enclosure next to the entry.

TAKE CARE TO SELECT AND INSTALL ADAPTORS THAT DO NOT REDUCE THE ENCLOSURE'S DEGREE OF PROTECTION WHEN IN USE IN ZONE 1 HAZARDOUS AREAS.



ATEX

UNUSED ENTRIES MUST BE FITTED WITH SUITABLY CERTIFIED FLAMEPROOF STOPPING PLUGS.



ATEX

IT IS A SAFETY REQUIREMENT THAT AT LEAST 5 FULL THREADS ARE ENGAGED BETWEEN THE ADAPTER, CABLE GLAND OR STOPPING PLUG, AND THE ELECTRICAL ENTRY WHEN THE UNIT IS IN OPERATION. NEVER OPERATE THE UNIT UNLESS THIS CONDITION IS MET.



ATEX

Alternative electrical entry threads

One or two electrical entries can be supplied with the following optional thread types:

- ISO to BS 3643 (1981) medium fit 6H up to M25 x 1.5
- DIN 40430 (1971) up to Pg21.
- USAS B2.1 (1968) gauging to clauses 36 & 37 up to 3/4" NPT.
- BS conduit to BS31 (1940) table 'A' up to 1"

- BSP to BS21(1985) standard threads only as clause 5.4 gauging to clause 5.2 system 'A' up to Rp3/4 (medium fit or better).

Wiring



DISCONNECT ALL SUPPLY CIRCUITS BEFORE WIRING



WIRE IN ACCORDANCE WITH LOCAL AND NATIONAL CODES. USE CABLES NO LARGER THAN 2.5 MM 2 (14 AWG)



DO NOT EXCEED ELECTRICAL RATINGS STATED IN LITERATURE AND ON NAMEPLATES.

The three switch terminals are clearly marked "NORMALLY CLOSED", "NORMALLY OPEN" and "COMMON". The following diagram can be used as a guide for wiring.

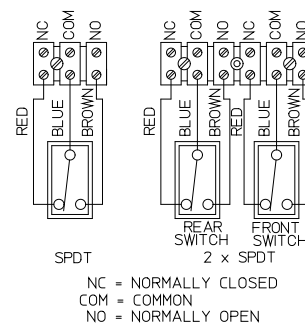

NC = NORMALLY CLOSED
COM = COMMON
NO = NORMALLY OPEN

FIG. 1A

FIG. 1A

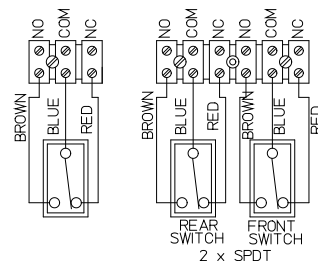

FIG. 1B

FIG. 1B

Fig.1A shows the state of electrical contacts at atmospheric pressure. **Note:** products with ranges below atmospheric pressure have the wiring reversed between the terminal block and the microswitch(es) to achieve this state (Fig 1B). **Note:** Position of electrical contacts might vary depending on instrument model, please refer to product internal marking.

Insert bare wires fully into the terminal block and tighten securely. Keep wiring tails to a minimum and check that wires do not interfere with the operating mechanism. Use the earthing / grounding points provided.

End of line resistors

Some products may be supplied to order fitted with end of line resistors. Resistors in use may generate a heat source. The type, quantity, configuration, fitment method and allowable electrical loads are limited by the scope of the certification.



ATEX

NEVER FIT END OF LINE RESISTORS OR MODIFY WITHOUT REFERENCE TO DELTA MOBREY

Replacing cover / lid on Flameproof enclosures



BEFORE CLOSING THE LID:

- ENSURE WIRE IS CLEAR OF ALL MOVING PARTS.
- ENSURE THAT WIRES DO NOT TOUCH THE LID AS IT IS CLOSED.

Thread, seal and contact surfaces may be lightly lubricated using a non-setting non-corrosive grease compatible with the lid seal.



DO NOT USE COPPER BEARING GREASE ON ALUMINIUM.

ATEX

Before connecting to electrical power, screw on cover/lid hand tight making sure that mating surfaces of the lid and enclosure are in contact. Use the locking screw provided to prevent casual and unauthorised removal of the cover/lid.



ATEX

IT IS A SAFETY REQUIREMENT THAT AT LEAST 5 FULL THREADS ARE ENGAGED BETWEEN THE COVER / LID AND THE ENCLOSURE WHEN THE UNIT IS IN OPERATION. NEVER OPERATE THE UNIT UNLESS THIS CONDITION IS MET.

OPERATION



ATEX

THIS UNIT CONTAINS POTENTIALLY SPARKING CONTACTS. DO NOT REMOVE THE COVER / LID WHILE ELECTRICAL POWER IS CONNECTED TO THE SWITCH AND / OR WHEN A FLAMMABLE GAS ATMOSPHERE IS PRESENT.

Adjustments

Pressure and Temperature Switches are supplied calibrated at the midpoint of their range and to a falling pressure or temperature unless otherwise specified.

Set point adjustments (All Models): (See fig. 2A and 2B)

1. Isolate the instrument from process and power.
2. Remove the lid to allow access
3. Slacken the set point lock screw.

4. Using a suitable spanner, rotate the range adjuster clockwise to increase the set point and counter-clockwise to decrease the set point.
5. Tighten the set point lock screw.

ENCLOSURE H,R,T,U & B

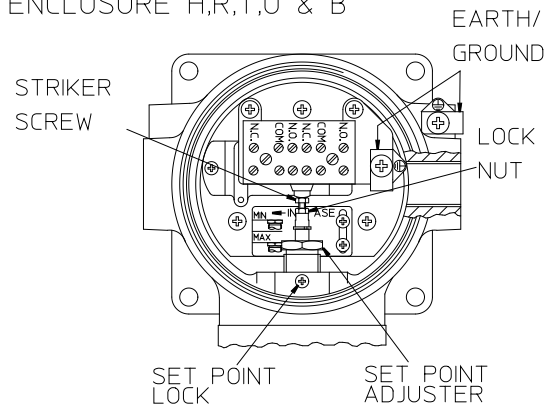

FIG. 2A

ENCLOSURES W & A

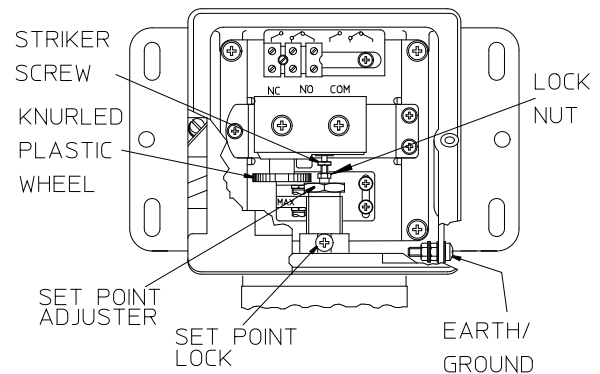

FIG. 2B

Switching differential adjustment (Model S22 only):

1. Isolate the instrument from process and power.
2. Remove the lid to allow access
3. Rotate the knurled plastic wheel on the microswitch to adjust the switching differential. Rotate clockwise to increase differential and counter-clockwise to reduce differential.
Note: Rotating the knurled plastic wheel will alter the operating value on rising pressure only.

Note: For accurate setting of Pressure and Differential Pressure models, a suitable pressure gauge must be used in conjunction with the above procedure. Do not attempt to set the switch outside the scale limits. For Temperature models a suitable calibrated temperature source should be used.



IF ADJUSTING THE SET-POINT, IT IS IMPORTANT TO USE A CALIBRATED PRESSURE SOURCE RATHER THAN THE REFERENCE SCALE PLATE TO ENSURE ACCURATE SETTING OF THE SWITCH. WHERE NECESSARY A NOTIFIED BODY SHOULD BE EMPLOYED TO CARRY OUT OR WITNESS THE SETTING OF CAT IV PED PRODUCTS.

Though the unit may be set anywhere within its range, for optimum performance, it is good practice to have a set point value between 25% and 75% of span.

The striker screw and lock nut are factory set and should not be adjusted. Should these parts be accidentally loosened, please contact Delta for assistance.

MAINTENANCE

Inspections should be carried out at quarterly to yearly intervals depending upon operating conditions. Isolate the unit from process and power and remove the lid. Check all terminals for tightness. Check that cable tails are not fouled or chafed. Check for internal condensation. Check that the gasket is seated properly in the lid recess and is not worn. Keep the enclosure and lid clear of dust build up. It is recommended that instruments used to provide an alarm are operated periodically to ensure they are functioning correctly. If further maintenance is required seek advice from DELTA MOBREY before attempting repair or replacement of parts.

SPECIAL CONDITIONS FOR SAFE USE

Applicable to all flameproof models of Industrial series (Pressure switch series S20).

- The flamepath between the pushrod and the bush assembly has a maximum diametrical clearance of 0.12 mm, which is less than that permitted by Table 2 of standard EN 60079-1. The user shall ensure this diametrical clearance is not exceeded in service.

Additional special condition for safe use that applies to model 2S24 and 3S24 only, when used in the boundary between an area requiring EPL Ga and an area requiring EPL Gb.

- The partition wall (the process diaphragm) is less than 1 mm thick and shall not be subjected to environmental conditions that adversely affect the partition wall.

- The unit shall be tested in such a way that the operational parameters (for example, pressure or temperature limits) stated on it by the manufacturer are verified.

NOTE: Under normal operating conditions where the process is not continually cycling above and below the set point, the wear will be minimal. To examine for wear remove the pressure sensor from the bottom of the enclosure and examine the rod and bush assembly for obvious wear. Do not attempt to remove the assembly and if in doubt seek assistance from Delta Mobrey.

DIMENSIONS

Models S21, S22, S24 (Pressure Switches)

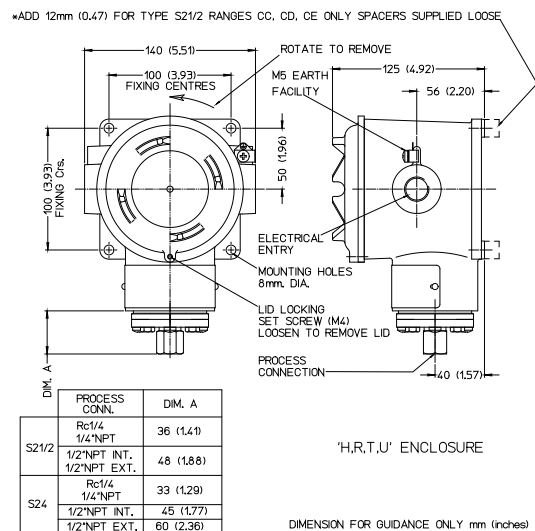
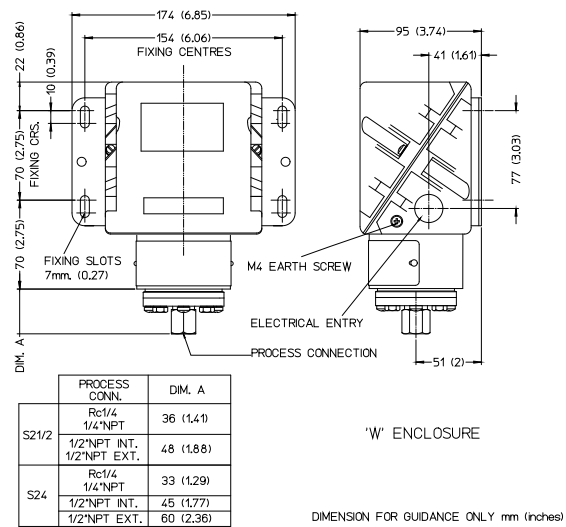

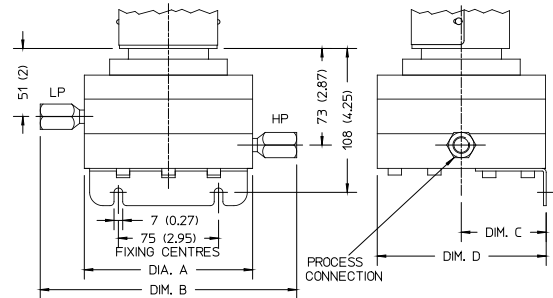
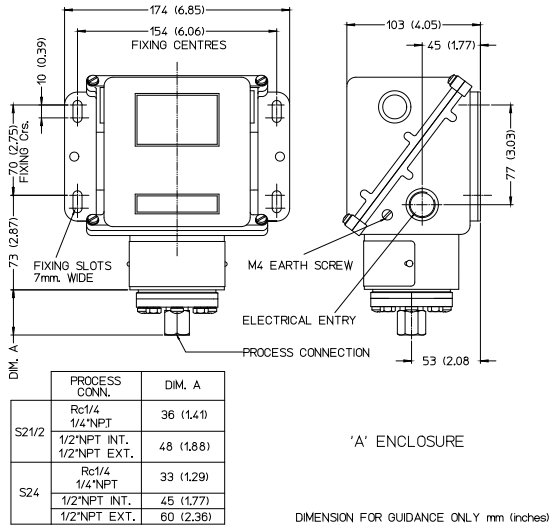

MODEL S34		RANGE	DIA. A	DIM. B	DIM. C	DIM. D
BD, CB, CE	126 (4.96)	192 (7.55) CODE A & F	63 (2.48)	126 (4.96)	63 (2.48)	126 (4.96)
		218 (8.58) CODE H				
		208 (8.18) CODE J				
DC, DD, EA	100 (3.93)	166 (6.35) CODE A & F	52 (2.04)	102 (4.01)	52 (2.04)	102 (4.01)
		192 (7.55) CODE H				
		182 (7.16) CODE J				

DIMENSIONS FOR GUIDANCE ONLY. mm (inches)

Models S31, S34 (Differential Pressure Switches)

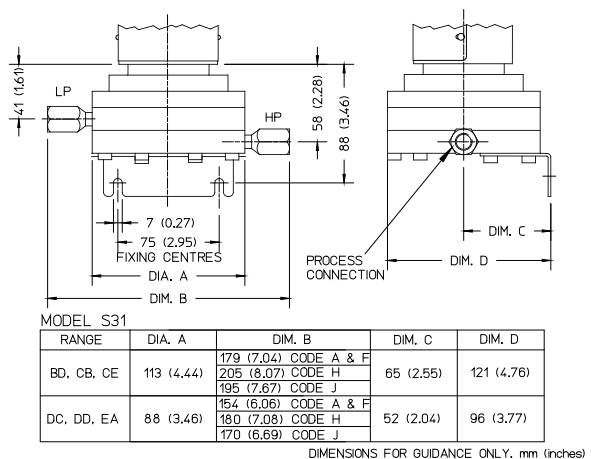
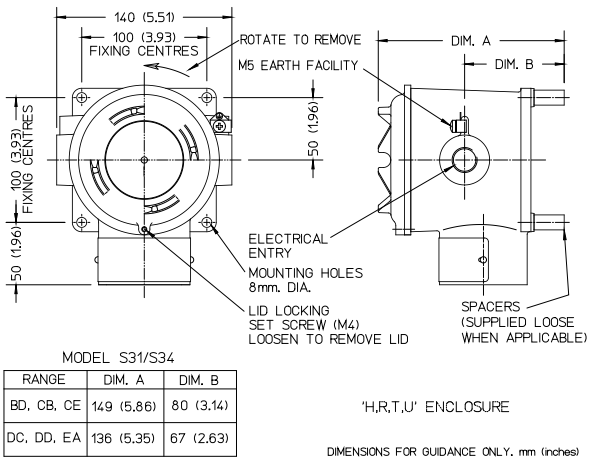
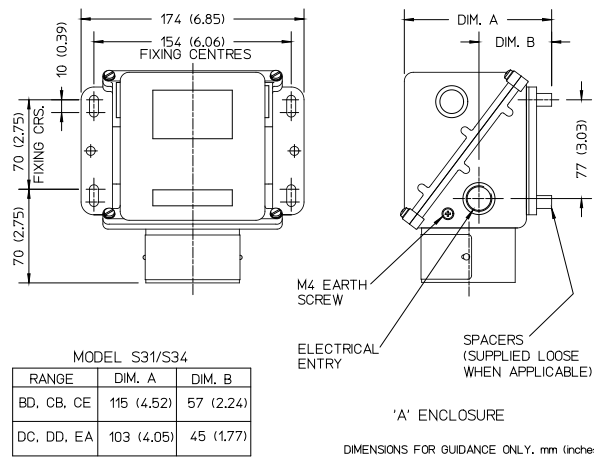
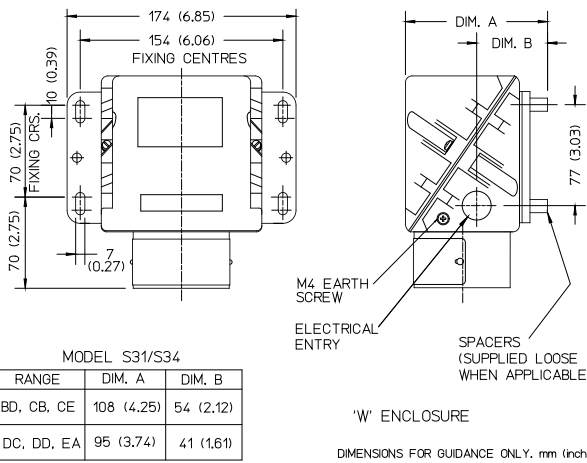

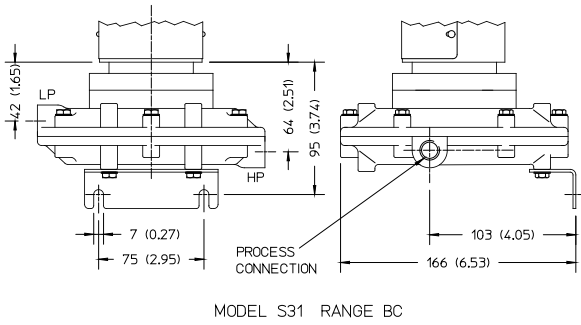

MODEL S31 RANGE BC

DIMENSIONS FOR GUIDANCE ONLY. mm (inches)

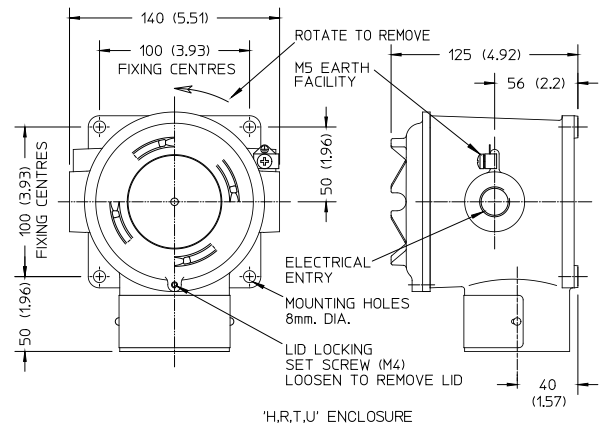

'H,R,T,U' ENCLOSURE

DIMENSIONS FOR GUIDANCE ONLY. mm (inches)

Model S71 (Temperature Switches)

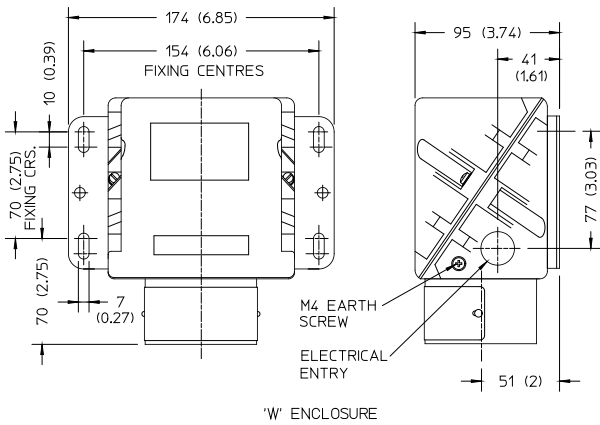

'W' ENCLOSURE

DIMENSIONS FOR GUIDANCE ONLY. mm (inches)

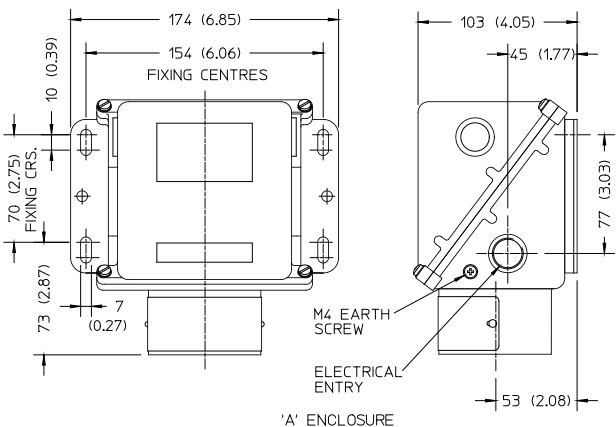
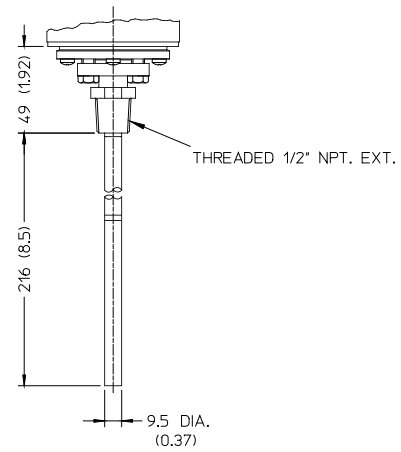

'A' ENCLOSURE

DIMENSIONS FOR GUIDANCE ONLY. mm (inches)

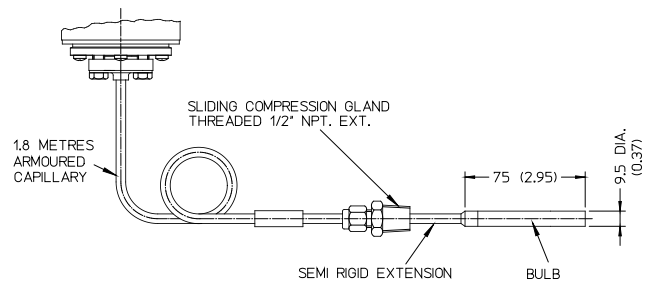

DIMENSIONS FOR GUIDANCE ONLY. mm(inches)